

---

# **Dahua IR Intelligent Speed Dome Installation Manual**

**Version 1.0.3**

**Dahua Technology CO., LTD**

---

# Table of Contents

<b>1</b>	<b>IR INTELLIGENT SPEED DOME INSTALLATION .....</b>	<b>1</b>
1.1	Installation Preparation .....	1
1.2	Initial Setup.....	2
1.3	Dial Switch Setup (Analog Speed Dome and HDCVI Speed Dome).....	2
1.3.1	Dial Switch .....	2
1.3.2	Parity Setup .....	3
1.3.3	Baud Rate .....	3
1.4	Reset and SD Card Installation (For network speed dome only) .....	4
1.5	Installation (For IR Analog and IR Network Speed Dome Both) .....	6
1.5.1	Quick Installation port.....	6
1.5.2	Cable Connection .....	7
1.5.3	Install the speed dome .....	7
<b>2</b>	<b>BRACKET DIMENSIONS .....</b>	<b>10</b>
2.1	Wall Mount Bracket .....	10
2.2	Hanging Mount Bracket (Multiple Lengths) .....	10
2.3	Corner Mount Bracket.....	11
2.4	Pole Mount Bracket.....	11
<b>3</b>	<b>WALL MOUNT BRACKET INSTALLATION.....</b>	<b>13</b>
3.1	Component Installation .....	13

---

<b>3.2</b>	<b>Installation.....</b>	<b>13</b>
3.2.1	Installation Requirements .....	13
3.2.2	Installation Steps.....	13
<b>4</b>	<b>HANG MOUNT BRACKET INSTALLATION .....</b>	<b>15</b>
4.1	Component Installation .....	15
4.2	Installation.....	15
4.2.1	Installation Requirements .....	15
4.2.2	Installation Steps.....	15
<b>5</b>	<b>CORNER MOUNT BRACKET INSTALLATION .....</b>	<b>17</b>
5.1	Component Installation .....	17
5.2	Installation.....	17
5.2.1	Installation Requirements .....	17
5.2.2	Installation Steps.....	17
<b>6</b>	<b>POLE MOUNT BRACKET INSTALLATION .....</b>	<b>19</b>
6.1	Installation.....	19
6.1.1	Installation Requirements .....	19
<b>7</b>	<b>APPENDIX I THUNDER PROOF AND SURGE PROTECTION .....</b>	<b>21</b>
<b>8</b>	<b>APPENDIX II ABOUT RS485 BUS .....</b>	<b>22</b>
8.1	RS485 Bus Main Feature .....	22
8.2	RS485 Bus Transmission Distance .....	22

---

8.3	The Problem in Practical Use .....	22
8.4	RS485 Bus FAQ .....	23
9	APPENDIX III THE RELATIONSHIP BETWEEN THE 24V AC CABLE DIAMETER AND THE TRANSMISSION DISTANCE.....	24
10	APPENDIX IV WIRE GAUGE REFERENCE SHEET .....	25

---

## Welcome

Thank you for purchasing our speed dome!

**Please read the following safeguards and warnings carefully before you install or use the product!**

---

# Important Safeguards and Warnings

## Safety Measures

### 1. Qualified Engineer Needed

- The installation engineer or maintenance engineer shall have corresponding CCTV system installation certificate or maintenance qualification certificate.
- The installation engineer or maintenance engineer shall have qualification certificate for work at height.
- The installation engineer or maintenance engineer shall have the basic knowledge and operation technique for low-voltage cable layout and low-voltage electronic cable connection.
- Please read the installation manual carefully and keep it well for future reference,
- We are not liable for any problems caused by unauthorized modifications or attempted repair.

### 2. Lifting Appliance Requirement

- Please select the proper speed dome installation mode and use the lifting appliances at the safety environment.
- The lifting appliances shall have the enough capacity to reach the installation height.
- The lifting appliances shall have safe performance.

**The precaution measures include two types: Warning and Note.**

- **Warning:** It is to alert you there is an optional risk of death or series injury!
- **Note:** It is to alert you there is an optional risk of damage or property loss!

## Warning

1. All installation and operation here should conform to your local electrical safety codes. We assume no liability or responsibility for all the fires or electrical shock caused by improper handling or installation.
2. Be sure to use all the accessories (such as power adapter) recommended by manufacturer.
3. Do not connect several speed domes to one power adapter. It may result in overheat or fire if it exceeds the rated load.
4. Before you connect the cable, install or uninstall, or begin the daily maintenance work, please turn off the power and unplug the power cable.
5. Please make sure the produce is secure firmly on the wall or the ceiling.
6. Please turn off the power and unplug the power cable, If there is any smoke, disgusting smell, or noise. Please contact your local retailer or customer service centre for help.

- 
7. All the examination and repair work should be done by the qualified service engineers. We are not liable for any problems caused by unauthorized modifications or attempted repair.

## Note

### 1. Safety Transportation

- Heavy stress, violent vibration or water splash are not allowed during transportation, storage and installation.
- This series product must use split type package during the transportation.
- We are not liable for any damage or problem resulting from the integrated package during the transportation.

### 2. When device is malfunction

Shut down the device and disconnect the power cable immediately if there is smoke, abnormal smell or abnormal function. Please contact your local retailer ASAP.

### 3. Do not try to dismantle or modify the device

- There is risk of personal injury or device damage resulting from opening the shell.
- Please contact your local retailer if there is internal setup or maintenance requirement.
- We are not liable for any problems caused by unauthorized modifications or attempted repair.

### 4. Do not allow other object falling into the device

- Please make sure there is no metal or inflammable, explosive substance in the speed dome.
- The above mentioned objects in the device may result in fire, short-circuit or damage.
- Please shut down the device and disconnect the power cable if there is water or liquid falling into the camera. Please contact your local retailer ASAP.
- Please pay attention to the camera. Avoid the sea water or rain to erode the camera.

### 5. Handle carefully

Do not allow this series product fall down to the ground.  
Avoid heavy vibration.

### 6. Installation Environment Requirement

- This series speed dome should be installed in a cool, dry place away from direct sunlight, inflammable, explosive substances and etc.
- This series product shall be away from the strong electromagnetism radiant, please keep it away from wireless power, TV transmitter, transformer and etc.

### 7. Daily Maintenance

- Please use the soft cloth to clean dust on the shell, or you can use soft cloth with cleaning liquid to clean the shell and then use soft cloth to make it dry.

- 
- Do not use gasoline, dope thinner or other chemical material to clean the shell. It may result in shell transfiguration or paint flake.
  - Do not allow the plastic or rubber material to touch the shell for a long time. It may result in paint flake.



---

# 1 IR INTELLIGENT SPEED DOME INSTALLATION

## 1.1 Installation Preparation

### Basic Requirement

- All installation and operation here should conform to your local electrical safety codes.
- Before installation, please open the package and check all the components are included. Please make sure the speed dome installation environment and installation mode can meet your requirement. If there is special requirement, please contact your local retailer for more information.
- We assume no liability or responsibility for all the fires or electrical shock caused by improper handling or installation.

### Check installation space and installation location intension

Please make sure the installation environment has enough space to install the speed dome and its corresponding bracket.

Please make sure the ceiling, wall and the bracket can support the speed dome and its corresponding installation component. It shall sustain the 8X weight of the speed dome.

### About cable

Please select the cable according to your transmission distance.

The minimum video coaxial-cable requirement is:

- 75 ohm.
- Full cable with copper conductor
- 95% knitted copper shield
- RS 485 communication cable

International Model	Max Transmission Distance (Ft/M)
RG59/U	750Ft (229M)
RG6/U	1,000Ft (305M)
RG11/U	1,500Ft (457M)

#### Note:

The above can be applied to analog speed dome and network speed dome.

International Model	Max Transmission Distance (M/Ft)
SYV-75-3	720P(25fps\30fps):500M/1640Ft
	720P(50fps\60fps):300M/984Ft
	1080P(25fps\30fps):300M/984Ft

#### Note:

The above can be applied to HDCVI speed dome.

### Set dial switch button

Set dial switch button according to control protocol and speed dome address. (Please refer to user's manual for detailed information.)

---

## **Please keep all package material well for future use**

Please keep speed dome package material well in case you need to send it back to your local retailer or manufacturer for maintenance work.

Non-original package material may result in device damage during the transportation.

## **Check Accessories**

Before the installation, please check the accessories one by one according to the packing list.

Please make sure all the components listed are includes.

## **1.2 Initial Setup**

The default setup is:

- Address: 1
- Baud rate: 9600
- Parity: None

## **1.3 Dial Switch Setup (Analog Speed Dome and HDCVI Speed Dome)**

### **1.3.1 Dial Switch**

Note:

Only when you cut off the power or restart the system after dial switch, can the setup be valid.

Please open the box and then take out the speed dome. See Figure 1-1.

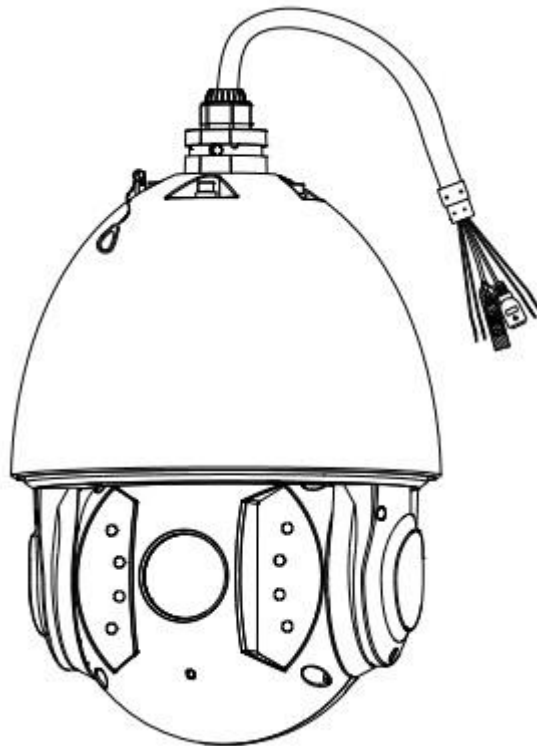

Figure 1-1

There are two dial switch buttons on the PCB. You can use them to set speed dome parity, baud rate, address and etc. See Figure 1-2 . It is 1 when you set the button as ON.

For the protocol dial switch, you can refer to the following sheet. 1 is the lowest bit and the 8 is the highest bit.

1	2	3	4	5	6	7	8	ON
NC			120Ω	Parity			Baud rate	Connect to the 120Ω

**Please note the IR speed dome can automatically recognize the industrial standard protocol, PELCO-D. PELCO-P. Usually you do not need to set the protocol.**

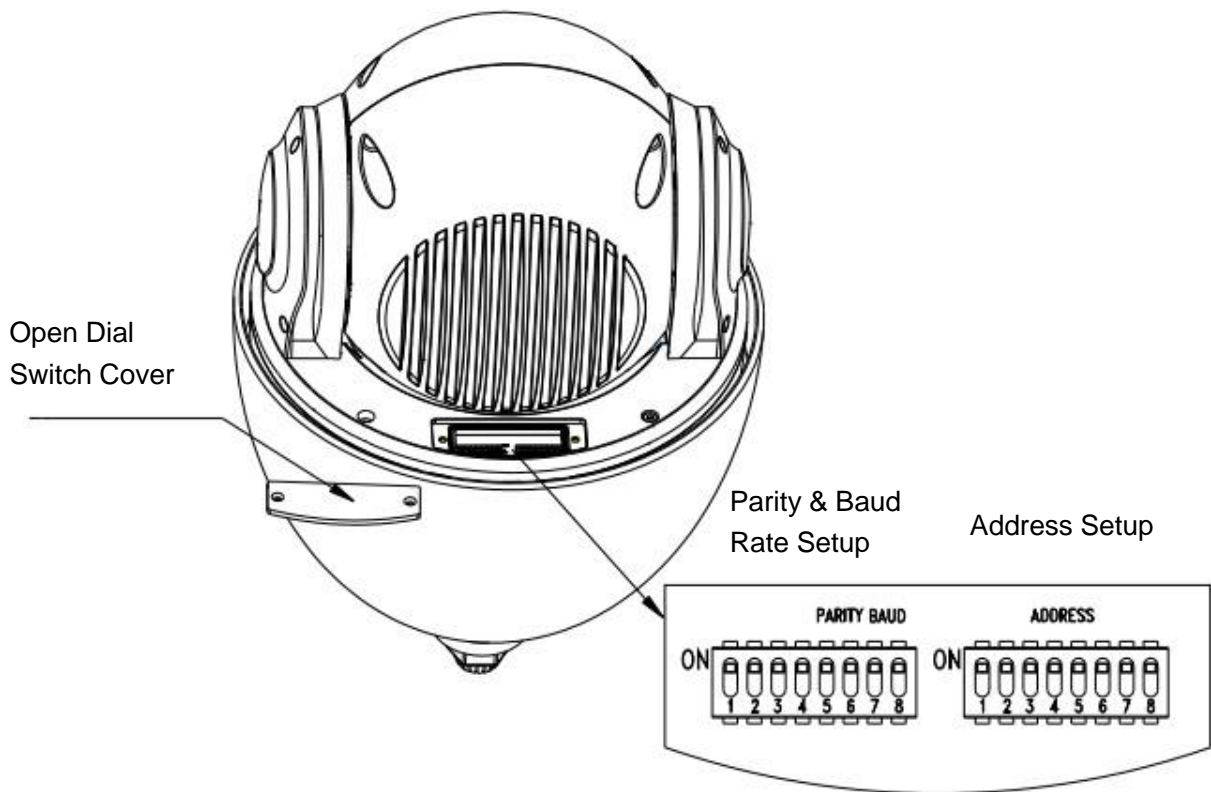

Figure 1-2

### 1.3.2 Parity Setup

Please refer to the parity setup sheet for detailed information.

5	6	Parity
OFF	OFF	NONE
ON	OFF	EVEN
OFF	ON	ODD
ON	ON	NONE

### 1.3.3 Baud Rate

Please refer to the baud rate sheet for detailed information.

7	8	Baud Rate

OFF	OFF	9600bps
ON	OFF	4800bps
OFF	ON	2400bps
ON	ON	1200bps

The encode mode adopts binary system. 1 to 8 is valid bit. The highest address bit is 255. You can refer to the following sheet for more information.

Address	1	2	3	4	5	6	7	8
1	OFF	OFF	OFF	OFF	OFF	OFF	OFF	OFF
1	ON	OFF	OFF	OFF	OFF	OFF	OFF	OFF
2	OFF	ON	OFF	OFF	OFF	OFF	OFF	OFF
3	ON	ON	OFF	OFF	OFF	OFF	OFF	OFF
4	OFF	OFF	ON	OFF	OFF	OFF	OFF	OFF
5	ON	OFF	ON	OFF	OFF	OFF	OFF	OFF
6	OFF	ON	ON	OFF	OFF	OFF	OFF	OFF
7	ON	ON	ON	OFF	OFF	OFF	OFF	OFF
8	OFF	OFF	OFF	ON	OFF	OFF	OFF	OFF
.....	.....							
254	OFF	ON	ON	ON	ON	ON	ON	ON
255	ON	ON	ON	ON	ON	ON	ON	ON

#### 1.4 Reset and SD Card Installation (For network speed dome only)

You can see there is a RESET button; dial switch button and Micro-SD card on the PCB after you open the dial switch cover. See Figure 1-2. Micro-SD card is to save the data.

You can refer to the sheet for dial switch information. 1 is the low bit and 2 is the high bit.

1	2	ON
120Ω	NC	Connect to 120Ω

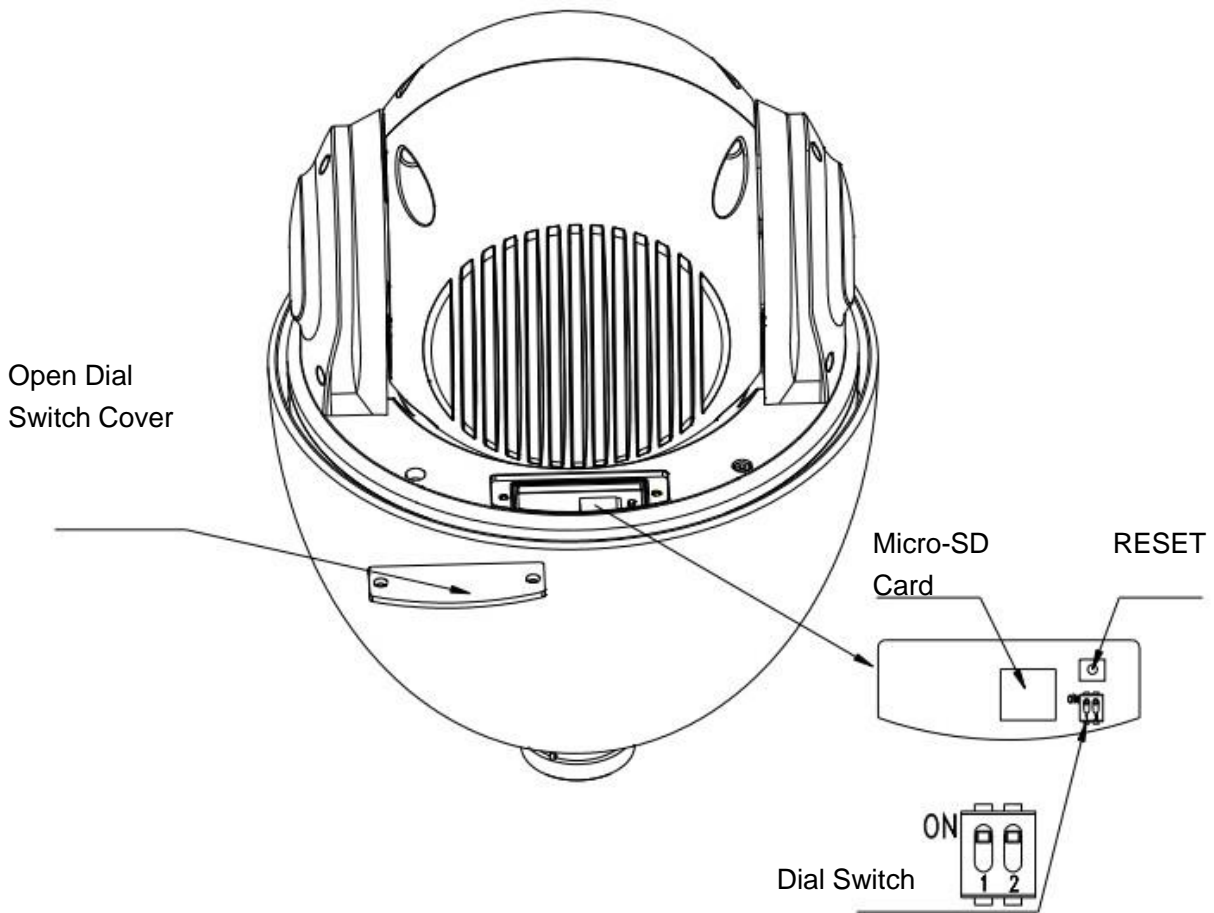

Figure 1-3

Note:

The SD card of some cameras is installed on the module; please refer to figure 1-4 for details.

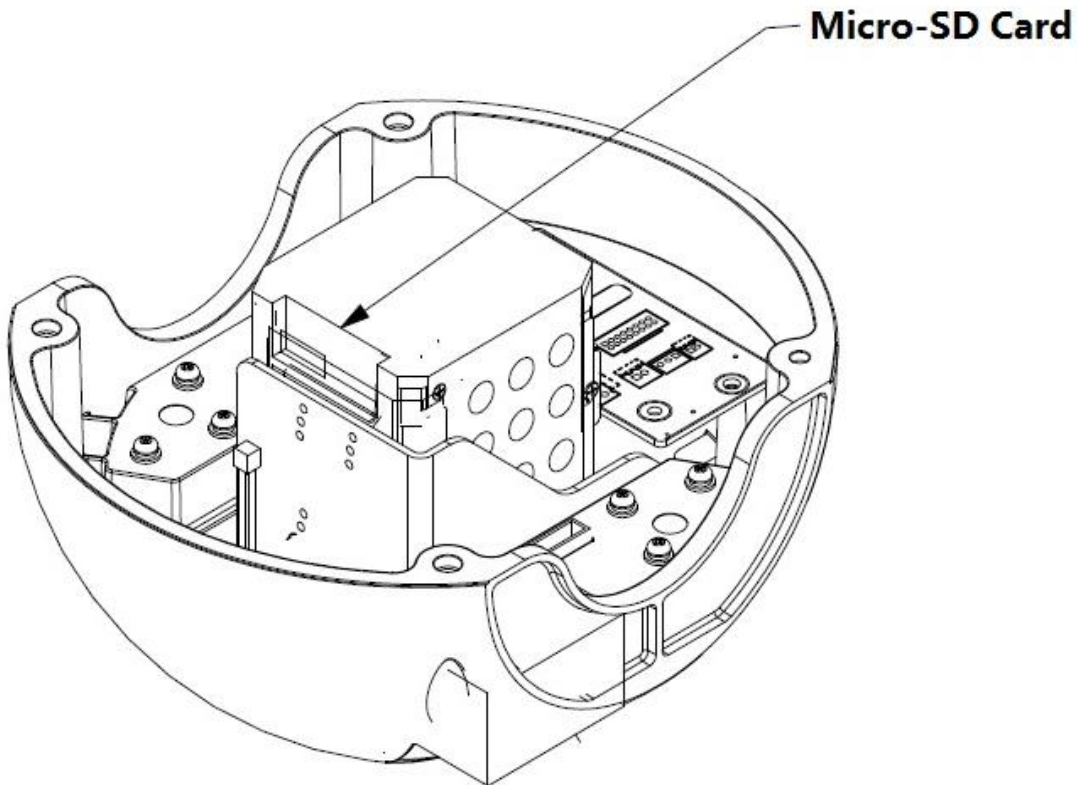

Figure 1-4

**Note:**

Please contact technical support of our company if you have any questions.

## 1.5 Installation (For IR Analog and IR Network Speed Dome Both)

The speed dome has various brackets suitable for different environments. For detailed information, please refer to chapter 2 and chapter 4. Here we are going to install the analog speed dome with the wall mount bracket.

### 1.5.1 Quick Installation port

Now you can install the quick installation port. Please twist Teflon tape around the screw thread of the quick installation port and turn it into the screw thread of the wall mount bracket. Use M4 stainless screws to secure firmly. See Figure 1-5.

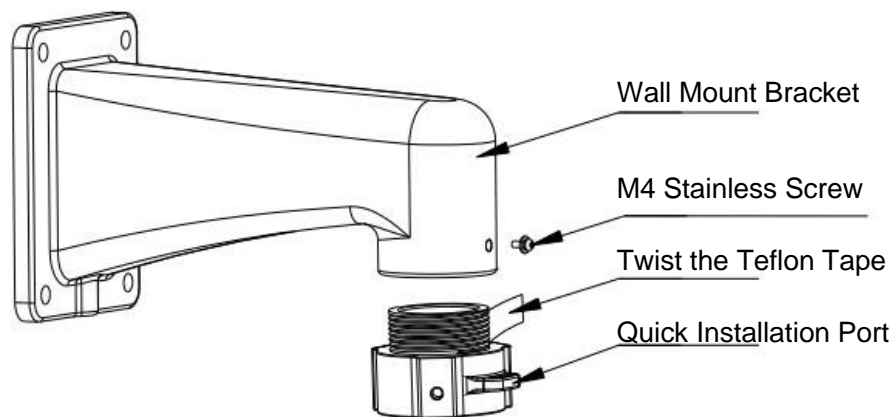

Figure 1-5

### 1.5.2 Cable Connection

- Connect the steel wire of the IR speed dome cover to the hook of the quick installation port.
- Connect the reserved integration cable of the wall mount bracket to the corresponding power cable, video/audio cable, RS485 control cable, alarm port, high frequency cable, fiber cable (if necessary) of the multiple-function composite cable of the IR speed dome. Paste the insulating tape in the connection position to do the proper waterproof work. See Figure 1-6.

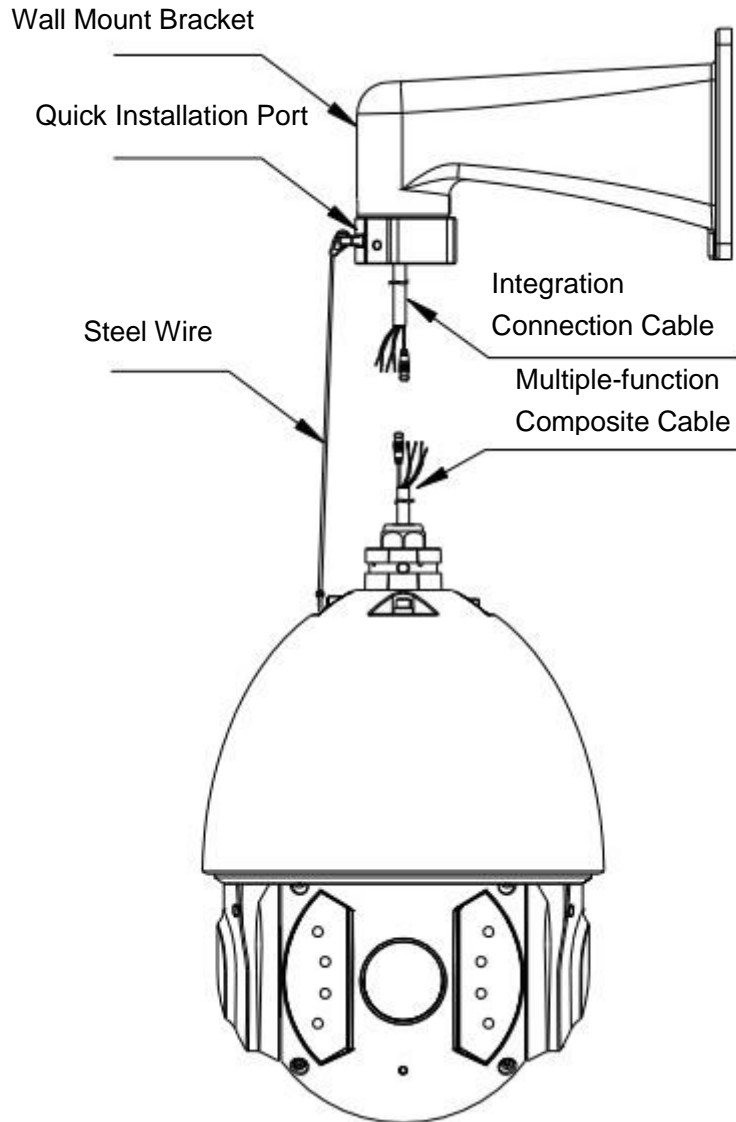

Figure 1-6

#### Note

The video port is covered the heat shrink tube of high shrinking ratio. After the video connection, please heat the tube to make sure the video port is damp proof and water proof.

### 1.5.3 Install the speed dome

---

After you complete the above steps, please pull the integration cable and multiple-function composite cable to the wall mount bracket.

Line up the straight edge of the flange of the IR speed dome to the straight edge of the quick installation port, and then push the speed dome to the bottom of the port slowly. Use your hands to turn the M6\*14 stainless screw (with spring washer) to the  $\Phi 6.5$  hole of the straight edge of the IR speed dome. Turn other two M6\*14 stainless screws to groove of IR speed dome flange. Use the inner hex tool to fix these three stainless screws. Now you have completed the installation. See Figure 1-7.

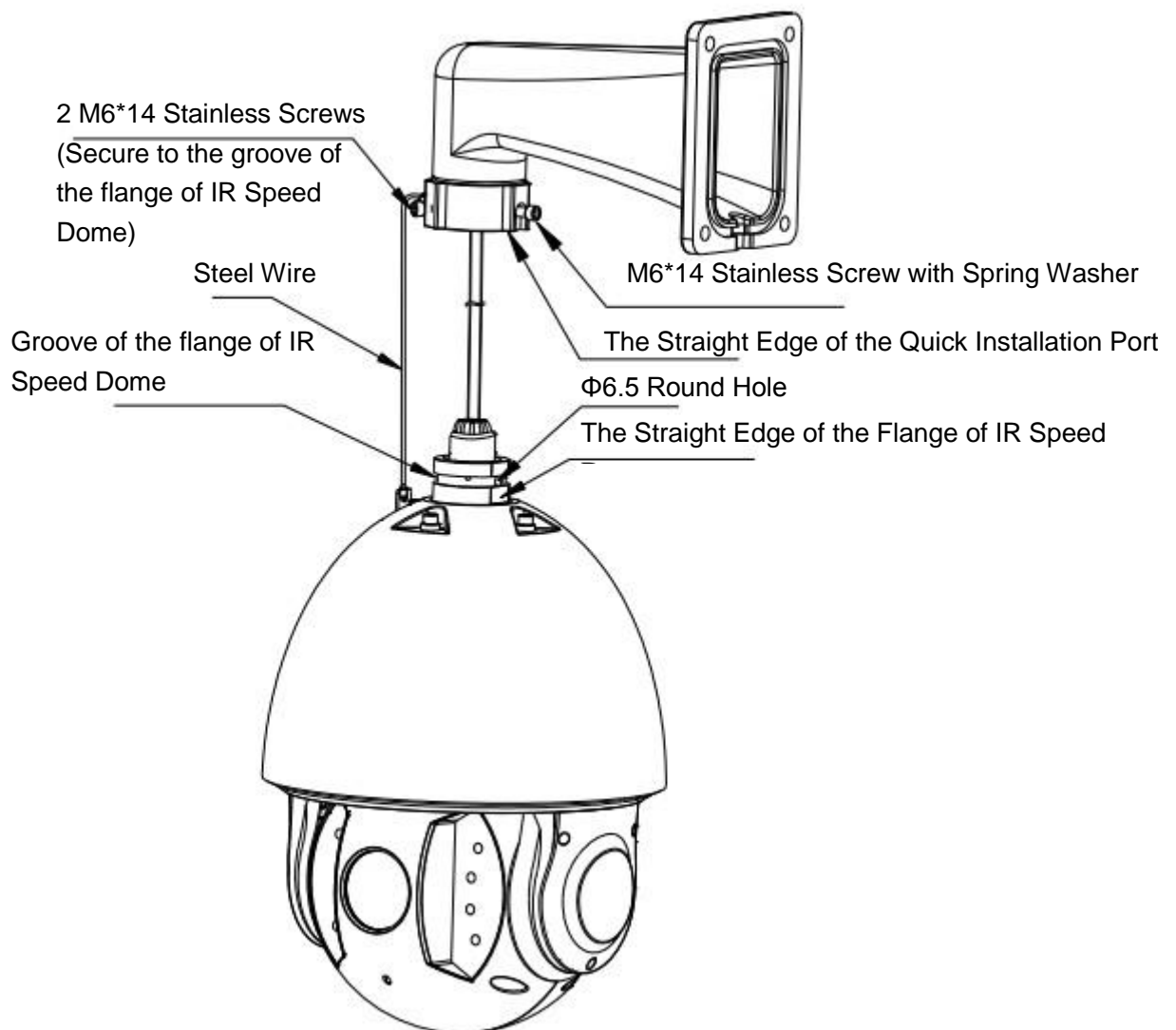

Figure 1-7

**Important**

**After the installation, please make sure:**

- The three stainless screws of the quick installation port are firmly secure.
- The IR speed dome is fixed.
- The speed dome is straight.
- The steel wire connection is firm.



---

After your installation, the interface is shown as in Figure 1-8.

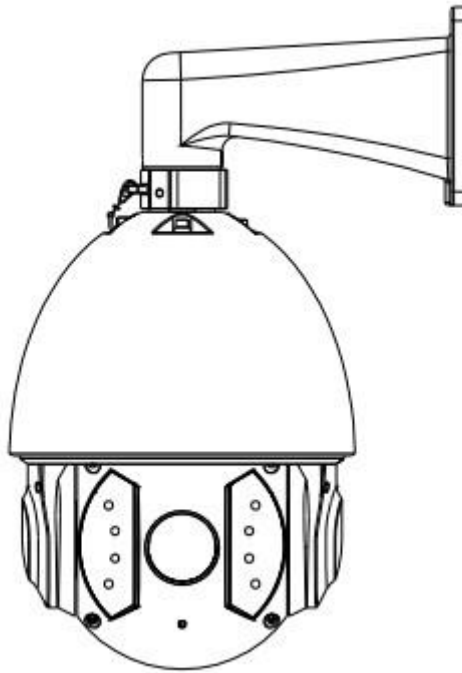

Figure 1-8

## 2 BRACKET DIMENSIONS

### 2.1 Wall Mount Bracket

The wall mount bracket dimensions are shown as below. See Figure 2-1.

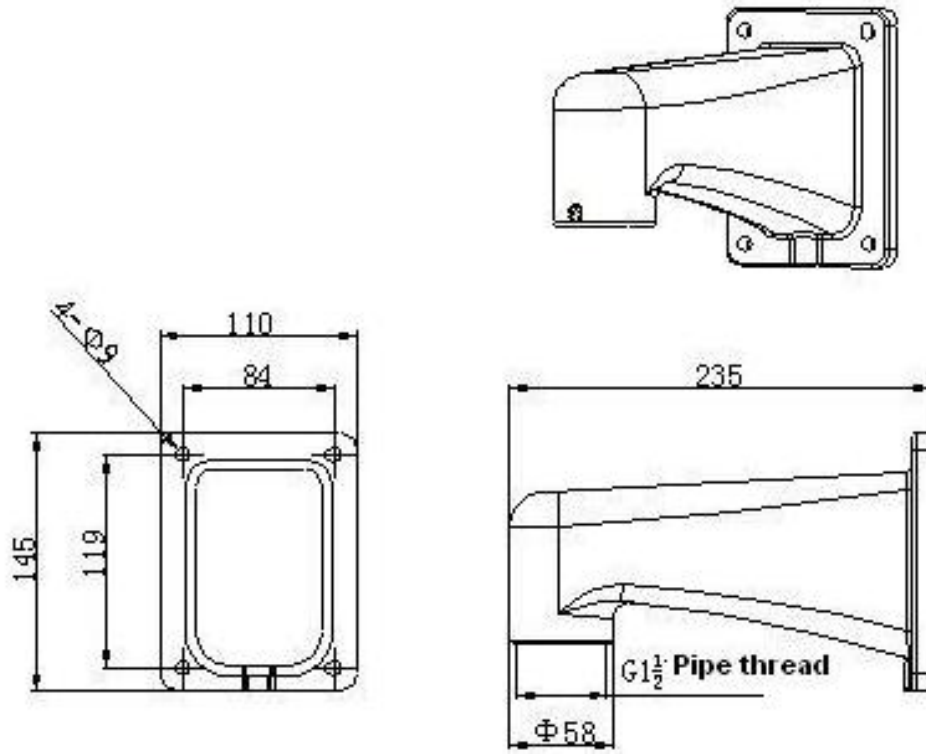

Figure 2-1

### 2.2 Hanging Mount Bracket (Multiple Lengths)

The hanging mount bracket is shown as below. See Figure 2-2.

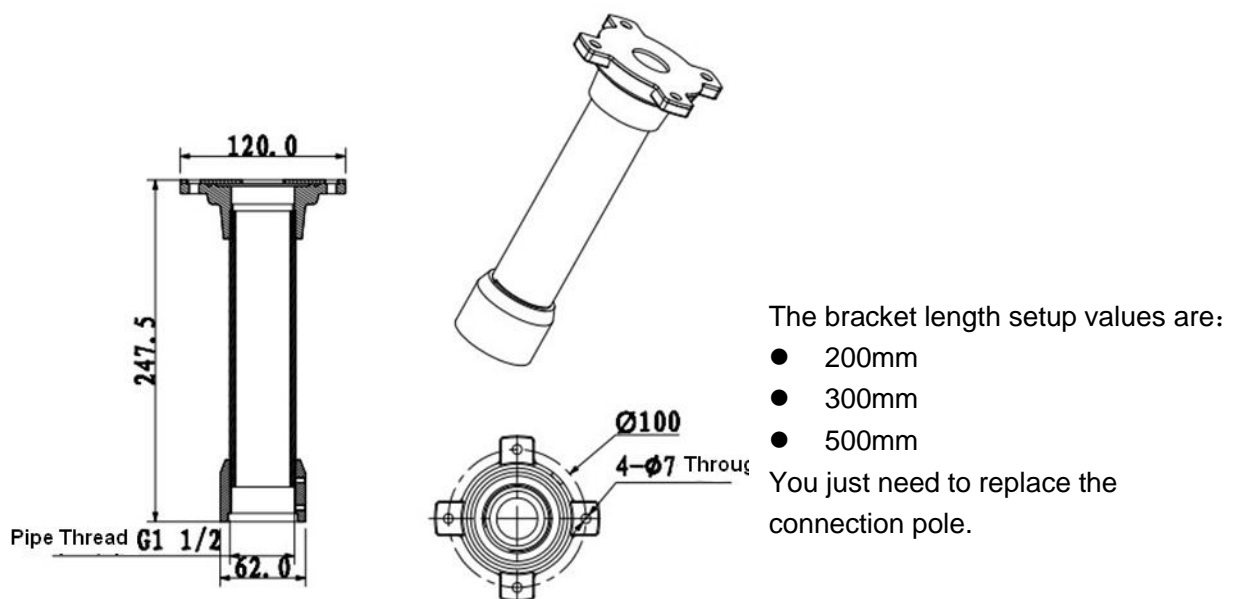

Figure 2-2

## 2.3 Corner Mount Bracket

The corner mount bracket is shown as below. See Figure 2-3.

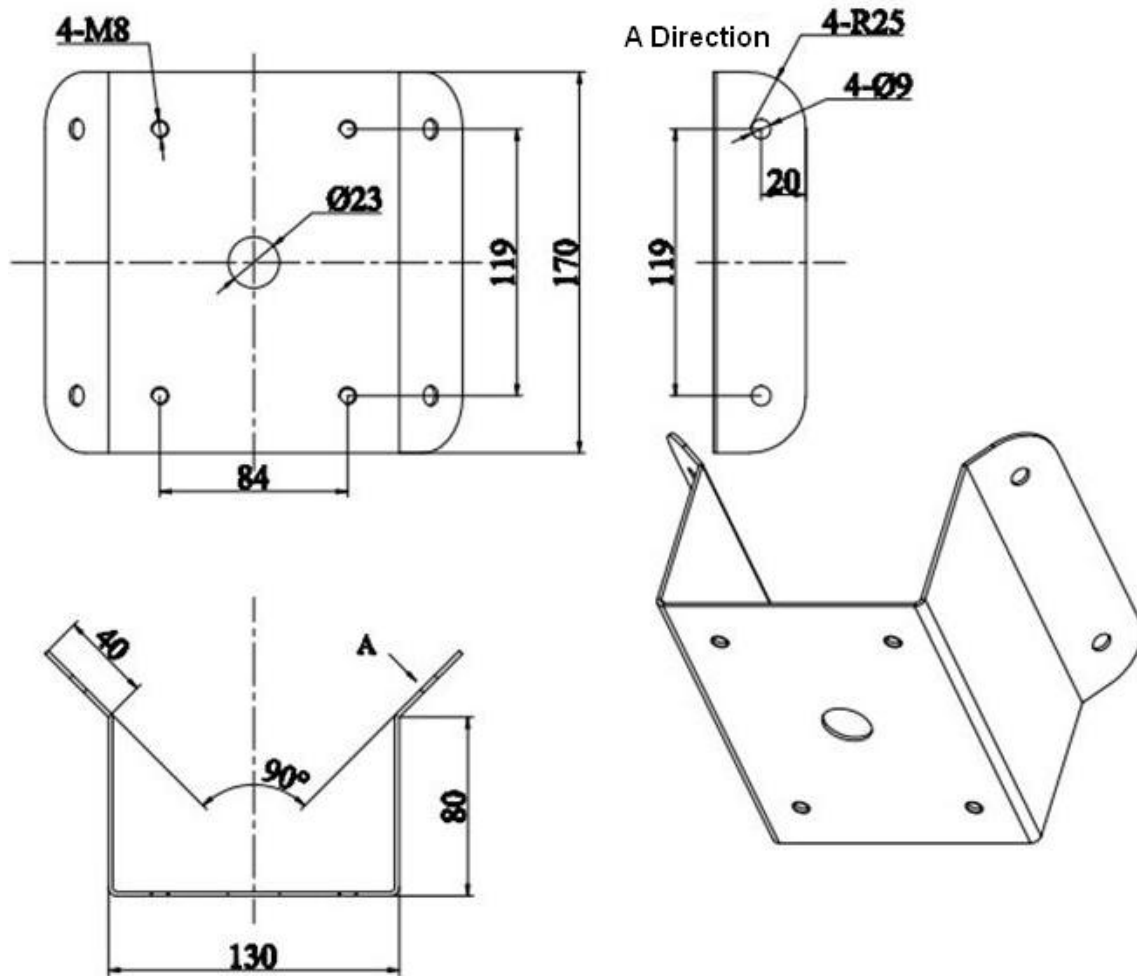

Figure 2-3

## 2.4 Pole Mount Bracket

The corner mount bracket is shown as below. See Figure 2-4.

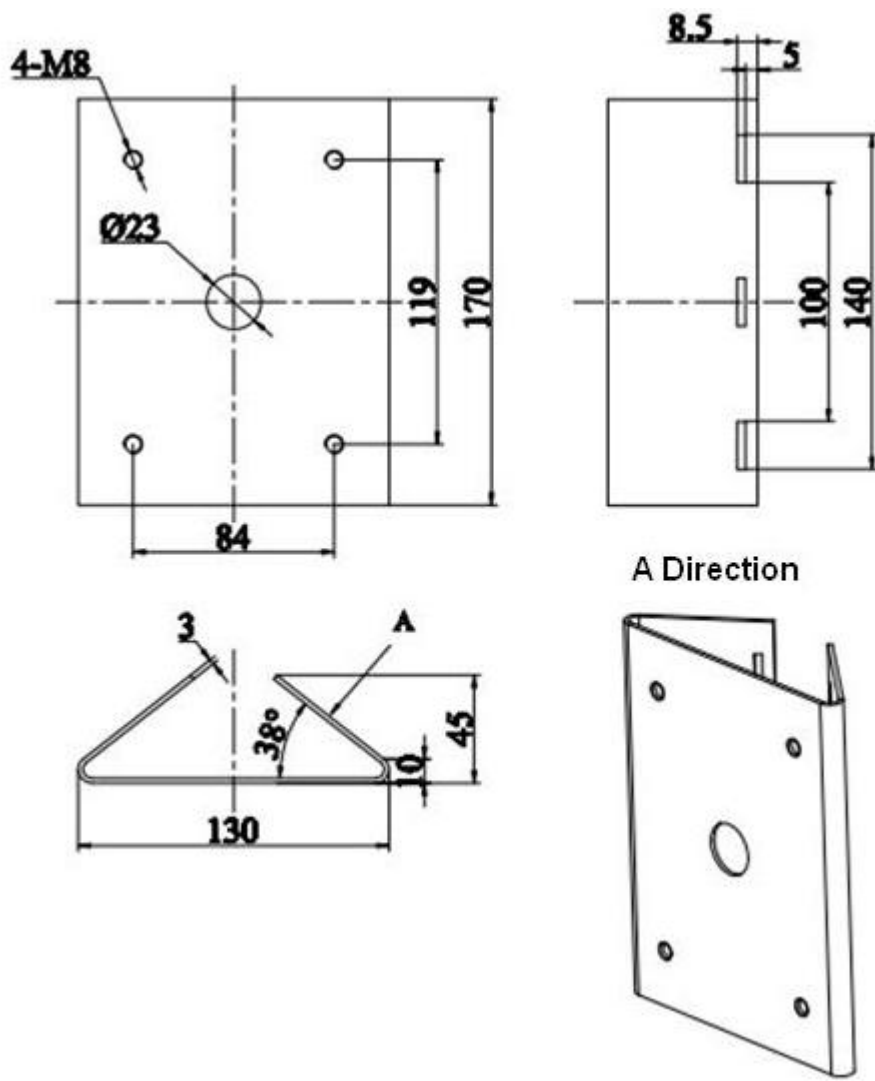

Figure 2-4

---

## 3 WALL MOUNT BRACKET INSTALLATION

### 3.1 Component Installation

Wall mount bracket is shown as below. See Figure 3-1.

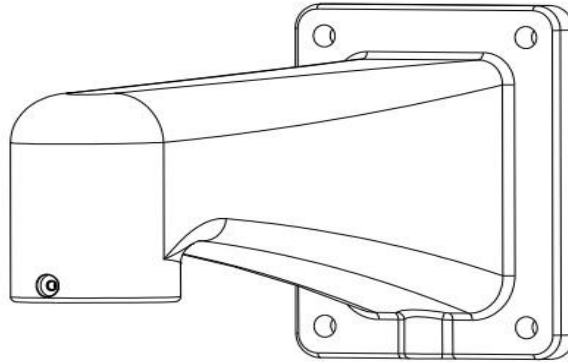

Figure 3-1

### 3.2 Installation

#### 3.2.1 Installation Requirements

The wall mount speed dome can be installed in the hard construction wall in the indoor or outdoor environments. Before the installation, please make sure:

- The wall is thick enough to install the expansion bolt.
- The wall can at least sustain the 8x weight of the speed dome.

#### 3.2.2 Installation Steps

Please draw four holes position in the wall according to the hole of the bottom of the wall mount bracket. Then you can dig four holes and insert the expansion bolts (not provided). Use four hex bolts and flat washer to fix the bracket in the expansion bolts. See Figure 3-2.

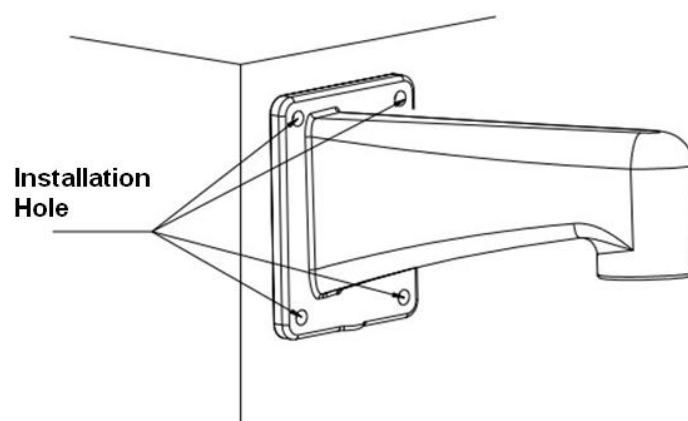

Figure 3-2

Install the IR speed dome in the bracket. See Figure 3-3.

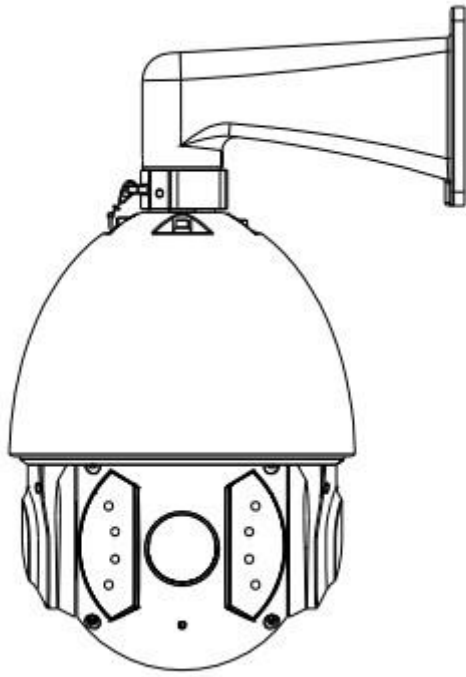

Figure 3-3

---

## 4 HANG MOUNT BRACKET INSTALLATION

### 4.1 Component Installation

Hang mount bracket and its components are shown as below. See Figure 4-1.

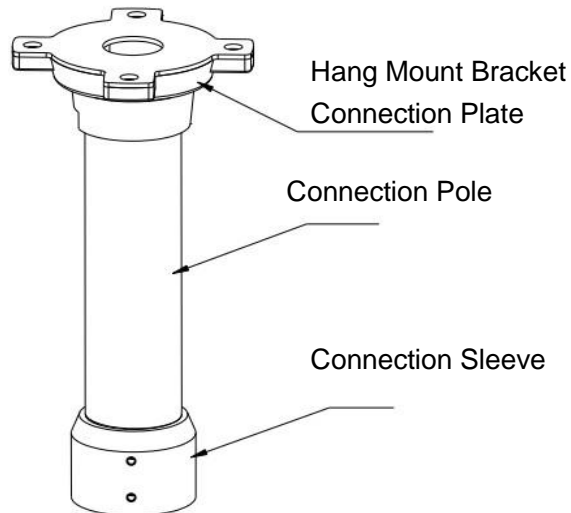

Figure 4-1

### 4.2 Installation

#### 4.2.1 Installation Requirements

The hang mount speed dome can be installed in the hard construction wall in the indoor or outdoor environments. Before the installation, please make sure:

- The wall is thick enough to install the expansion bolt.
- The wall can at least sustain the 8x weight of the speed dome.

#### 4.2.2 Installation Steps

Loosen the M4 bolt in the flange side to separate the flange and steeve. Pull the integration cable through the airproof slot of the bottom of the flange and then connect to the centre hole of the flange. Please secure the flange in the ceiling. See Figure 4-2. **Please note, if the speed dome is installed in the outdoor environments, you need to paste the silica gel on the surface of the flange and the surface and the cable exit.**

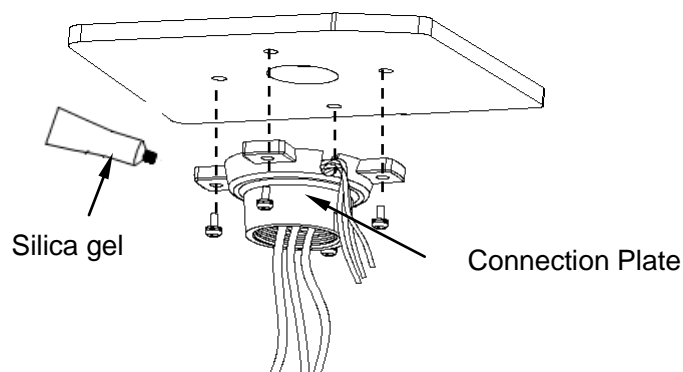

Figure 4-2

Pull the cable through the steeve and then secure the steeve to the flange. Fix the M4 bolt. See Figure 4-3.

**Please note, if the speed dome is installed in the outdoor environments, you need to paste enough Teflon tape at the top screw thread of the steeve and then turn the steeve to the flange firmly. Please paste the silica gel on the steeve connection surface to do the waterproof work.**

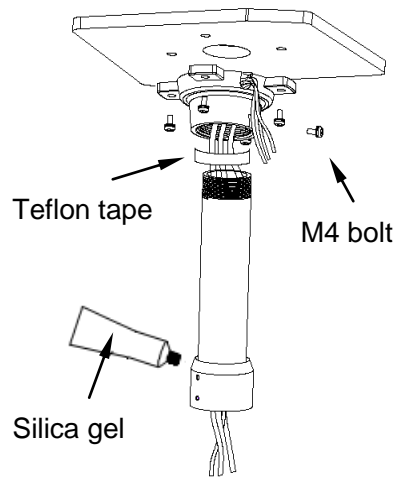
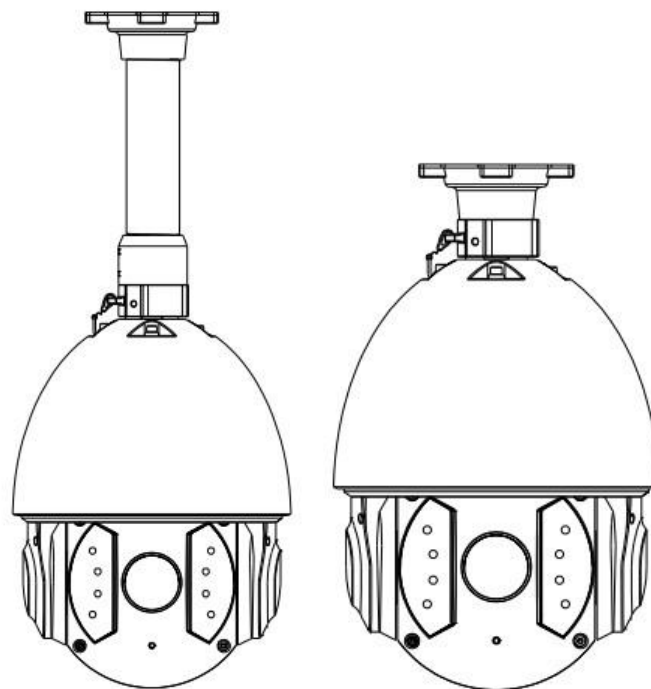

Figure 4-3

Please refer to chapter 1.5 for detailed installation information. See Figure 4-4.



Long pole

Without pole

Figure 4-4



---

## 5 CORNER MOUNT BRACKET INSTALLATION

### 5.1 Component Installation

Corner mount bracket and its components are shown as below. See Figure 5-1.

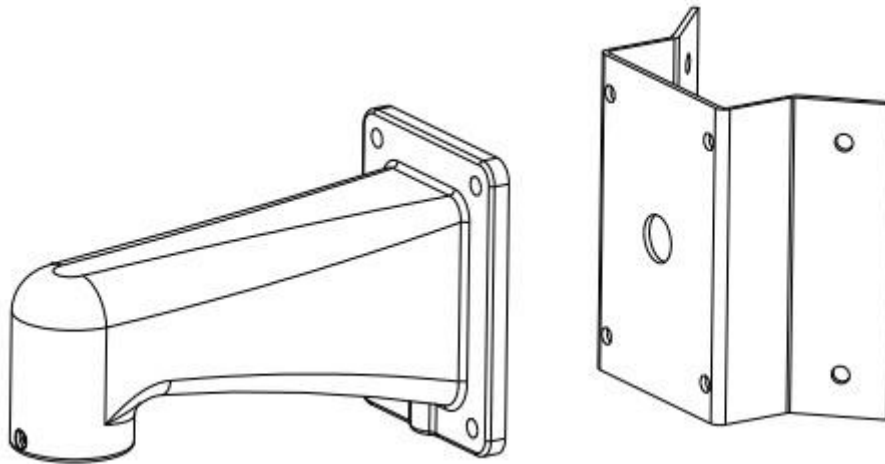

Figure 5-1

### 5.2 Installation

#### 5.2.1 Installation Requirements

The corner mount speed dome can be installed in the hard construction wall in the indoor or outdoor environments where there is a 90 degrees angle. Before the installation, please make sure:

- The wall is thick enough to install the expansion bolt.
- The wall can at least sustain the 8x weight of the speed dome.

#### 5.2.2 Installation Steps

Please draw four holes position in the wall according to the holes of the corner installation accessories. See Figure 5-2.

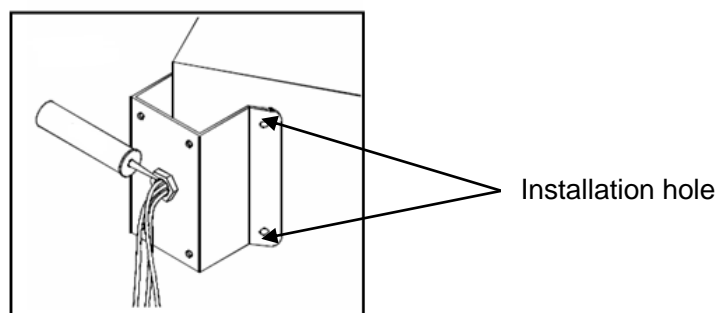

Figure 5-2

Then you can dig four holes according to the holes of the corner mount accessories and insert the M8 expansion bolts. Pull the integration cable through the centre hole of the bottom of the corner bracket, the waterproof adhesive, and the centre of the bracket. Please reserve the enough cable connection length and then use the M8 expansion bolt to secure the corer mount bracket chassis on the wall. See Figure 5-3.

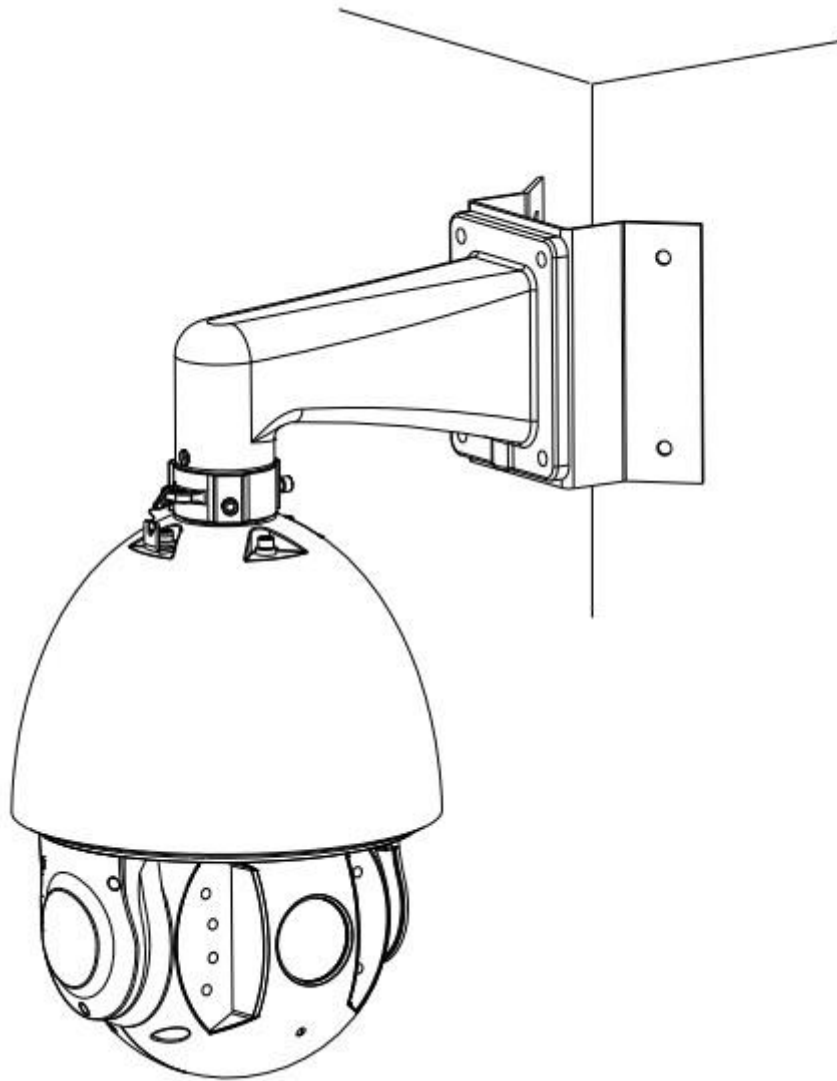

Figure 5-3

---

## 6 POLE MOUNT BRACKET INSTALLATION

Pole mount bracket and its components are shown as below. See Figure 6-1.

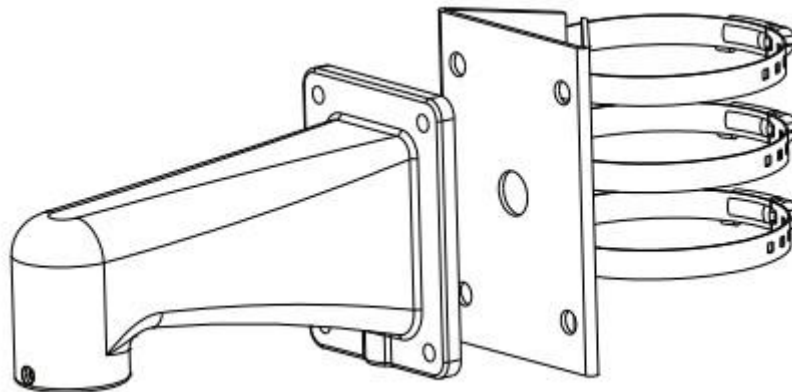

Figure 6-1

### 6.1 Installation

#### 6.1.1 Installation Requirements

The corner mount speed dome can be installed in the hard construction wall in the indoor or outdoor environments.

Before the installation, please make sure the pole bracket can sustain the 8X weight of the speed dome.

The diameter of the pole structure shall comply with the installation dimension of the clamp.

Default factory clamp is six inches for the column of  $\phi 130-152\text{mm}$ . It can work with the pole

installation bracket. You can adjust the diameter and the value (clamp specification) is :  $\phi 59-$

$82\text{mm}$ 、 $\phi 84-108\text{mm}$ 、 $\phi 103-127\text{mm}$ 、 $\phi 130-152\text{mm}$ 、 $\phi 155-178\text{mm}$ 、 $\phi 180-203\text{mm}$ 、 $\phi 194-216\text{mm}$ .

For special dimensions, please contact us for more information.

Please refer to Figure 6-2 to install clamp and pole bracket.

Pull the cable out of the pole accessories and then use clamp to fix the pole accessories to the pole. Finally, you can use glass cement to the output hole to secure waterproof.

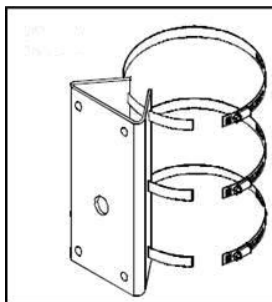

Clamp and pole bracket connection

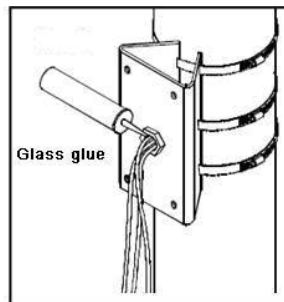

Pole bracket and the pole connection

Figure 6-2

---

After you installed bracket and external cover, pull the power cable through the hanging bracket and then use the clamp to fix the hanging bracket to the wall. Please paste glass glue on the cable exit. See Figure 6-3.

Please refer to chapter 1.5 for detailed installation information.

**After the installation, please make sure the clamp is firmly secure in case it may result in clamp broken.**

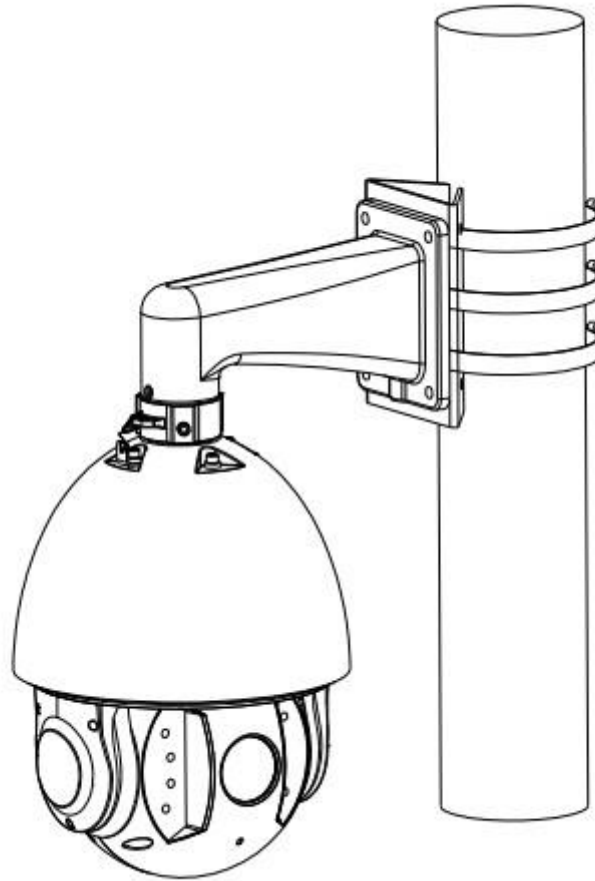

Figure 6-3

## 7 APPENDIX I THUNDER PROOF AND SURGE PROTECTION

This series speed dome adopts TVS lighting protection technology. It can effectively prevent damages from various pulse signals below 1500W, such as sudden lighting and surge. While maintaining your local electrical safety code, you still need to take necessary precaution measures when installing the speed dome in the outdoor environment.

- The distance between the signal transmission cable and high-voltage device (or high-voltage cable) shall be at least 50 meters.
- Outdoor cable layout shall go under the penthouse if possible.
- For vast land, please use sealing steel tube under the land to implement cable layout and connects one point to the earth. Open floor cable layout is forbidden.
- In area of strong thunderstorm hit or near high sensitive voltage (such as near high-voltage transformer substation), you need to install additional high-power thunder protection device or lightning rod.
- The thunder protection and earth of the outdoor device and cable shall be considered in the building whole thunder protection and conform to your local national or industry standard.
- System shall adopt equal-potential wiring. The earth device shall meet anti-jamming and at the same time conforms to your local electrical safety code. The earth device shall not short circuit to N (neutral) line of high voltage power grid or mixed with other wires. When connect the system to the earth alone, the earth resistance shall not be more than  $4\Omega$  and earth cable cross-sectional area shall below  $25\text{ mm}^2$ . See Figure 7-1.

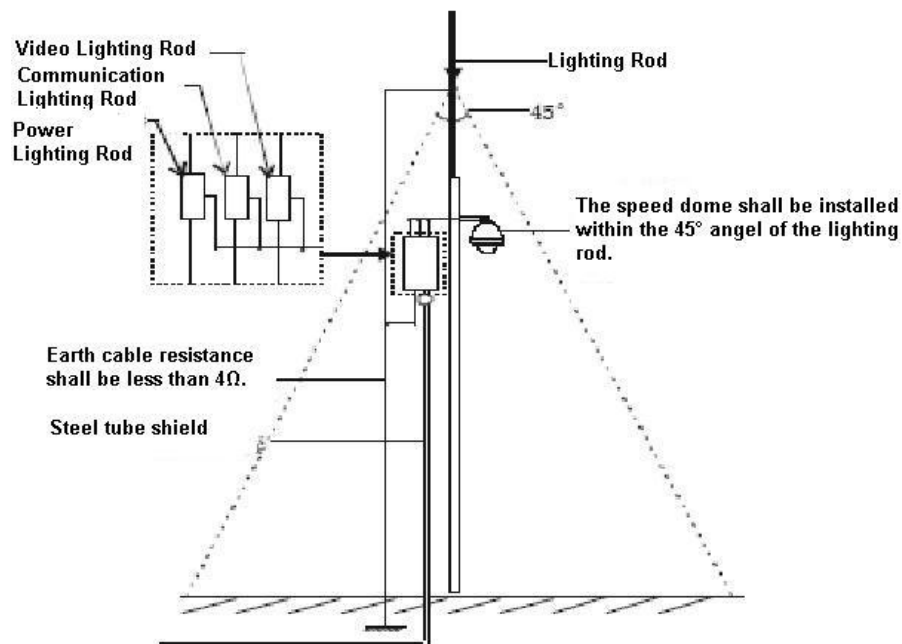

Figure 7-1

---

## 8 APPENDIX II ABOUT RS485 BUS

### 8.1 RS485 Bus Main Feature

RS485 is semi duplex communication cable of impedance  $120\Omega$  . Its max load amount is 32 effective loads (including main control device and devices to be charged).

### 8.2 RS485 Bus Transmission Distance

When we take 0.56mm (24AWG) twisted-pair as communication cable, the max transmission distance (theoretically) are listed below (according to different baud rates).

Baud Rate	Max Distance
2400 BPS	1800M
4800 BPS	1200M
9600 BPS	800M

In the following situations, the max transmission distance shall become shorter accordingly:

- The communication cable is a little bit thin;
- The surrounding environment has strong electromagnetic interference;
- There are too much devices connected to the RS485 bus;

And vice versa, the max transmission distance shall become longer.

### 8.3 The Problem in Practical Use

In practical usage, we usually adopt star type connection. The terminal resistance shall connect to the furthest two devices (Such as device 1# and device 15# in Figure 8-1 ). But this connection way does not conform to RS485 Bus standard. When the distances between devices are too long, the signal reflection occurs and anti-jamming decreases, thus the signal reliability becomes very low. You can see speed dome is not under control or speed dome is running automatically and can not stop.

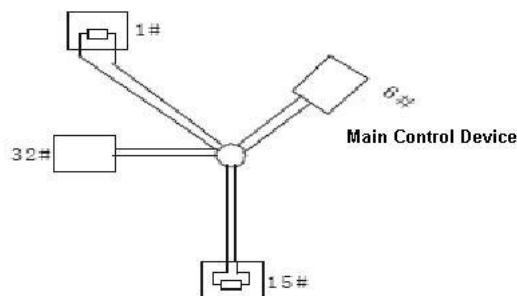

Figure 8-1

In this situation, we recommend RS485 distributor. This device can turn star type connection into the connection that conforms to RS485 bus industry standard, which can avoid the above mentioned problems and enhance communication reliability. See Figure 8-2.

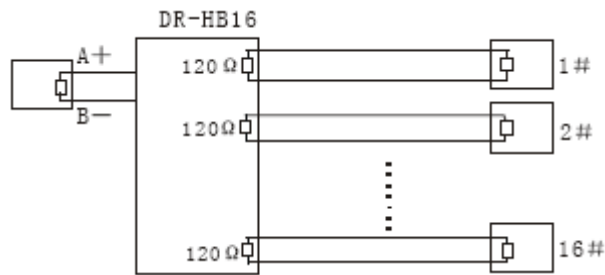

Figure 8-2

## 8.4 RS485 Bus FAQ

Phenomenon	Possible Reasons	Solution
Speed dome can run self-diagnosis but I can not control it.	<ul style="list-style-type: none"> <li>● Host address(baud rate) and speed dome address(baud rate) are not match;</li> <li>● Positive and negative end of RS485 Bus are misconnected;</li> <li>● Connection cable is loose;</li> <li>● RS485 Bus connection are cut off;</li> </ul>	<ul style="list-style-type: none"> <li>● Modify host or speed dome setup ;</li> <li>● Switch RS485 positive end and negative end;</li> <li>● Fix connection cable firmly;</li> <li>● Replace RS485 Bus.</li> </ul>
I can control the speed dome but is not smooth	<ul style="list-style-type: none"> <li>● RS485 Bus connection are not good;</li> <li>● One RS485 bus is off;</li> <li>● The distance between host and speed dome is too far;</li> <li>● Parallel connected too much speed domes.</li> </ul>	<ul style="list-style-type: none"> <li>● Connect RS 485 Bus again;</li> <li>● Replace RS485 Bus;</li> <li>● Add terminal matching resistance;</li> <li>● Add RS485 distributor.</li> </ul>

## 9 APPENDIX III THE RELATIONSHIP BETWEEN THE 24V AC CABLE DIAMETER AND THE TRANSMISSION DISTANCE

It is the recommended transmission distance when the cable diameter is fixed and the 24V AC power consumption is below 10%. For the AC device, the max permission voltage power consumption is 10%. For example, when a device of rated power 80VA installed from the transformer 35 inches (10m), then the min cable diameter is 0.8000mm.

Feet(m) W	mm	0.8000	1.000	1.250	2.000
	10	283 (86)	451 (137)	716 (218)	1811 (551)
20	141 (42)	225 (68)	358 (109)	905 (275)	
30	94 (28)	150 (45)	238 (72)	603 (183)	
40	70 (21)	112 (34)	179 (54)	452 (137)	
50	56 (17)	90 (27)	143 (43)	362 (110)	
60	47 (14)	75 (22)	119 (36)	301 (91)	
70	40 (12)	64 (19)	102 (31)	258 (78)	
80	35 (10)	56 (17)	89 (27)	226 (68)	
90	31 (9)	50 (15)	79 (24)	201 (61)	
100	28 (8)	45 (13)	71 (21)	181 (55)	
110	25 (7)	41 (12)	65 (19)	164 (49)	
120	23 (7)	37 (11)	59 (17)	150 (45)	
130	21 (6)	34 (10)	55 (16)	139 (42)	
140	20 (6)	32 (9)	51 (15)	129 (39)	
150	18 (5)	30 (9)	47 (14)	120 (36)	
160	17 (5)	28 (8)	44 (13)	113 (34)	
170	16 (4)	26 (7)	42 (12)	106 (32)	
180	15 (4)	25 (7)	39 (11)	100 (30)	
190	14 (4)	23 (7)	37 (11)	95 (28)	
200	14 (4)	22 (6)	35 (10)	90 (27)	



## 10 APPENDIX IV WIRE GAUGE REFERENCE SHEET

Metric bare wire diameter (mm)	AWG	SWG	Bare wire cross section (mm <sup>2</sup> )
0.050	43	47	0.00196
0.060	42	46	0.00283
0.070	41	45	0.00385
0.080	40	44	0.00503
0.090	39	43	0.00636
0.100	38	42	0.00785
0.110	37	41	0.00950
0.130	36	39	0.01327
0.140	35		0.01539
0.160	34	37	0.02011
0.180	33		0.02545
0.200	32	35	0.03142
0.230	31		0.04115
0.250	30	33	0.04909
0.290	29	31	0.06605
0.330	28	30	0.08553
0.350	27	29	0.09621
0.400	26	28	0.1257
0.450	25		0.1602
0.560	24	24	0.2463
0.600	23	23	0.2827
0.710	22	22	0.3958
0.750	21		0.4417
0.800	20	21	0.5027
0.900	19	20	0.6362
1.000	18	19	0.7854
1.250	16	18	1.2266
1.500	15		1.7663
2.000	12	14	3.1420
2.500			4.9080
3.000			7.0683

---

**Note**

- This manual is for reference only. Slight difference may be found in the user interface.
- All the designs and software here are subject to change without prior written notice.
- All trademarks and registered trademarks are the properties of their respective owners.
- If there is any uncertainty or controversy, please refer to the final explanation of us.
- Please visit our website or contact your local service engineer for more information.

**Dahua Technology CO., LTD.**

Address: No.1199 Bin'an Road, Binjiang District, Hangzhou, PRC.

Postcode: 310053

Tel: +86-571-87688883

Fax: +86-571-87688815

Email:overseas@dahuatech.com

Website: www.dahuatech.com