

Residential Outdoor Station

Two-wire IP Outdoor Station



- 1/3-in. 1.3 MP CMOS Imager
- Wide-angle Field of View
- Night Vision and Voice Indication
- Supports Remote Intercom with Mobile App (requires VTNC3000A)
- Video and Audio Messaging
- IP54 Ingress Protection, IK07 Vandal Resistance
- Stainless Steel Panel, Surface- or Flush-mounted



Technical Specification

System

Main Processor	Embedded Micro Processor
Operating System	Embedded Linux

Operation

Input	Single Mechanical Button
-------	--------------------------

Video

Video Compression	H.264
Image Sensor	1/3-in. 1.3 MP CMOS Sensor
Lens	2.8 mm
Angle of View	Horizontal: 90° Vertical: 120°
Day/Night	Color Image

Audio

Compression	G.711
Input	Omnidirectional Microphone
Output	Built-in Speaker
Bi-directional Talk	Supports Dual-way Bi-directional Talk

Interface

Door Control	Two (2) Channels: <ul style="list-style-type: none"> • One (1) Relay Out for Main Lock • One (1) Channel Extended by Access Control Module
Alarm Input	Two (2) Channels: <ul style="list-style-type: none"> • One (1) Channel, Unlock Button • One (1) Channel, Feedback
RS485	One (1) Port
Tamper Switch	One (1)

Network

Ethernet	10/100 Mbps, Self-adaptive
Network Protocol	TCP/IP

Certifications

Safety	Power Supply: UL Certified
Electromagnetic Compatibility (EMC)	FCC CFR 47 Part 15 subpart B ANSI C63.4 - 2009 EN 55022:2010, EN 55024:2010, EN 50130-4:2011, EN 61000-6-3:2007, EN 61000-3-2:2006+A1:2009 EN 61000-3-3:2008, IEC 61000-4-2:2008, IEC 61000-4-3:2010, IEC 61000-4-4:2012, IEC 61000-4-5:2005, IEC 61000-4-6:2008, IEC 61000-4-8:2009, IEC 61000-4-11:2004

Electrical

Power	24 VDC Power supplied via DHI-VTNC3000A.
Power Consumption	Standby: ≤ 1 W Operation: ≤ 10 W

Environmental

Operating Temperature	-40° C to +60° C (-40° F to +140° F)
Operating Humidity	10% to 90%, Relative
Ingress Protection	IP54
Vandal Resistance	IK07

Construction

Material	Stainless Steel
Dimensions	129.90 mm x 32.17 mm x 140.0 mm (5.08 in. x 1.27 in. x 5.51 in.)
Net Weight	0.80 kg (1.76 lb)
Installation	Surface- or Flush-mount

Accessories

VTOB107	Flush-Mount Box
Material	Metal
Dimensions	125.0 mm x 135.0 mm x 56.0 mm (4.92 in. x 5.31 in. x 2.20 in.)
Weight	0.8 kg (1.76 lb)
VTOB108	Surface-Mount Box
Material	Metal
Dimensions	145.0 mm x 134.0 mm x 88.0 mm (5.71 in. x 5.28 in. x 3.46 in.)
Weight	1.0 kg (1.76 lb)

Dimensions (mm/in.)

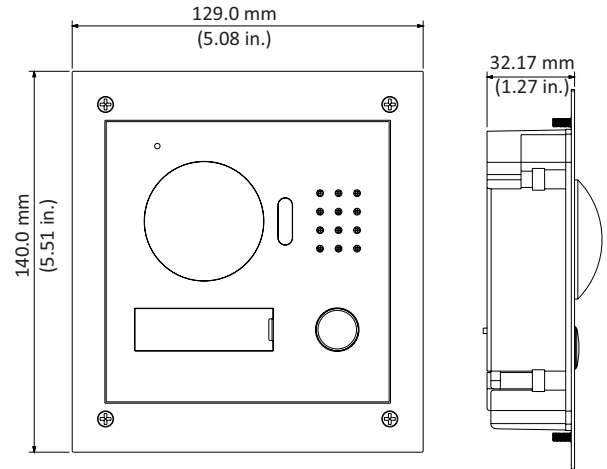

View Area

