

# Intercom Surface-mount Box

For a Two-module DHI-VTO4202F Series Modular Door Station



### Technical Specification

Material	Steel
Color	Silver
Installation Method	Surface-mount
Dimensions (L x H x W)	145.0 mm x 261.20 mm x 59.70 mm (5.71 in. x 10.28 in. x 2.35 in.)
Ingress Protection	IP65 (silicone sealant required)
Net Weight	1.55 kg (3.42 lb)
Gross Weight	1.89 kg (4.17)
Compatibility	<ul style="list-style-type: none"> <li>DHI-VTO4202F Series Modular Door Station (two-module system)</li> <li>VTM125 Intercom Front Panel Bezel</li> </ul>

### Dimensions (mm/in.)

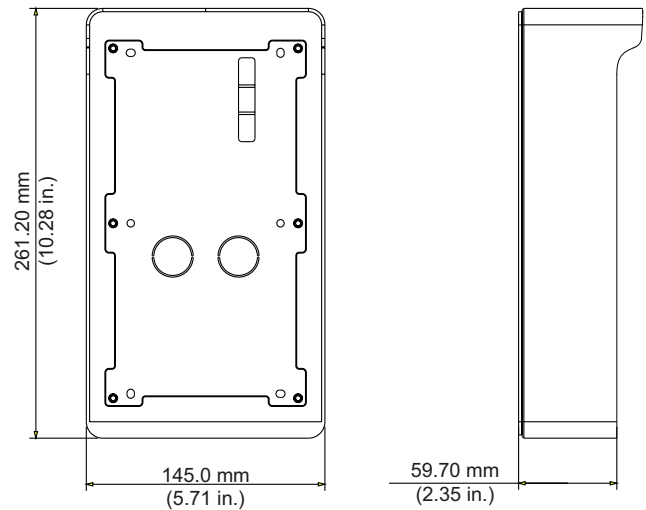

### Installation

