

Intelligent Video Surveillance Server

User's Manual

V3.0.1

Foreword

General

The user's manual (hereinafter referred to as "the manual") describes the structure, function and operation of the intelligent video surveillance server (hereinafter referred to as "IVSS" or the Device).

Model

8-HDD, 12-HDD, 16-HDD, and 24-HDD.






HDD Number	Model
8	IVSS708
12	IVSS712
16	IVSS716, IVSS716D, IVSS716DR
24	IVSS724, IVSS724D, IVSS724DR



- In the model name, R indicates that the model has redundant power.
- In the model name, D indicates that the model has an LED screen.

Safety Instructions

The following categorized signal words with defined meaning might appear in the manual.

Signal Words	Meaning
 DANGER	Indicates a high potential hazard which, if not avoided, will result in death or serious injury.
 WARNING	Indicates a medium or low potential hazard which, if not avoided, could result in slight or moderate injury.
 CAUTION	Indicates a potential risk which, if not avoided, could result in property damage, data loss, lower performance, or unpredictable result.
 TIPS	Provides methods to help you solve a problem or save you time.
 NOTE	Provides additional information as the emphasis and supplement to the text.

Revision History

Version	Revision Content	Release Time
V3.0.1	Added crowd distribution, and data security notes.	December 2019
V3.0.0	<ul style="list-style-type: none">Added search by image, cluster, and fisheye dewarp.Updated chapters including intelligent operation and device management according to the new device version.	December 2019
V2.1.0	<ul style="list-style-type: none">Added video metadata, vehicle recognition, and vehicle comparison functions.Updated the intelligent operation chapter.	June 2019
V2.0.1	Added attention in important safeguards and warnings.	January 2019
V2.0.0	Updated figures of 16-HDD series IVSS.	December 2018
V1.0.0	First release.	November 2018

About the Manual

- The manual is for reference only. If there is inconsistency between the manual and the actual product, the actual product shall prevail.
- We are not liable for any loss caused by the operations that do not comply with the manual.
- The manual would be updated according to the latest laws and regulations of related regions. For detailed information, see the paper manual, CD-ROM, QR code or our official website. If there is inconsistency between paper manual and the electronic version, the electronic version shall prevail.
- All the designs and software are subject to change without prior written notice. The product updates might cause some differences between the actual product and the manual. Please contact the customer service for the latest program and supplementary documentation.
- There still might be deviation in technical data, functions and operations description, or errors in print. If there is any doubt or dispute, see our final explanation.
- Upgrade the reader software or try other mainstream reader software if the manual (in PDF format) cannot be opened.
- All trademarks, registered trademarks and the company names in the manual are the properties of their respective owners.
- Please visit our website, contact the supplier or customer service if there is any problem occurred when using the device.
- If there is any uncertainty or controversy, see our final explanation.

Important Safeguards and Warnings

This section introduces the correct application method of IVSS. Read the Manual carefully before use to prevent danger and property loss. Strictly conform to the Manual during application and keep it properly after reading.

Operating Requirement

- The IVSS needs to be installed in restricted access areas, and anyone who operates the device needs to be aware of the safety requirements of the device.
- Do not place and install the IVSS in an area exposed to direct sunlight or near heat generating devices.
- Do not install the IVSS in a humid, dusty or fuliginous area.
- Install the IVSS at stable places horizontally.
- Make the IVSS stay away from liquid.
- Install the IVSS at well-ventilated places; do not block its ventilation opening.
- Use the IVSS only within rated input and output range.
- Do not dismantle the IVSS arbitrarily.
- Transport, use and store the IVSS within allowed humidity and temperature range.

Power Requirement













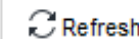
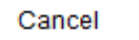
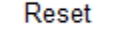



- Be sure to use the designated battery type. Otherwise there might be explosion risk.
- Be sure to use batteries according to requirements; otherwise, it might result in fire, explosion or burning risks of batteries!
- To replace batteries, only the same type of batteries can be used.
- Be sure to dispose the exhausted batteries according to the instructions.
- The product shall use electric wires (power wires) recommended by this area, which shall be used within its rated specification.
- Be sure to use standard power adapter matched with the device. Otherwise, the user shall undertake resulting personnel injuries or device damages.
- Use power supply that meets SELV (safety extra low voltage) requirements, and supply power with rated voltage that conforms to Limited Power Source in IEC60950-1. For specific power supply requirements, see device labels.
- Products with category I structure shall be connected to grid power output socket, which is equipped with protective grounding.
- Appliance coupler is a disconnecting device. During normal use, please keep an angle that facilitates operation.

Attention

- Do not insert or take out the expansion drawer without power off first.

- AI module does not support hot plugging. If you need to replace the AI module, power off the Device first. Otherwise, it will lead to file damage on the AI module.

Signal Words

Icon/Button	Description
	After you have entered the password, press the icon with your pointer, you can see the password is displayed in letters and number; Release mouse or move pointer to other places, the password is displayed in the form of black dots.
	Add icon. Click the icon, system can display the hidden applications interface. You can view or open the applications.
	Help information. Move the mouse pointer to the icon, device can display help information.
	Display or hide icon. Click the icon to display the hidden menu. Now the icon is shown as  . Click  again to hide the menu items.
<input type="checkbox"/>	Check the box, you can select multiple menu items at the same time. <input checked="" type="checkbox"/> means selected.
<input type="radio"/>	Check box, select one menu item, <input checked="" type="radio"/> means selected.
	Drop-down box, click the box to view the drop-down menu.
	Enable icon. <ul style="list-style-type: none"> • : Disabled. • : Enabled • : The function cannot be enabled. • : The function cannot be disabled.
	Refresh button, click it to view the latest configuration information.
	Cancel button, click it to cancel the configuration items and then return to the upper-level menu.
	Click Reset to clear all search criteria settings.
	Page switch. <ul style="list-style-type: none"> • : Page up/page down. • , go to the first page or the last page.








Icon/Button	Description
	<p>Play window. Input page number in the box. Click Jump to go to the specified page.</p>
	<p>Filter icon. Click it to set filter criteria.</p>
	<p>Select icon. Click the icon, the system displays a check box, so you can select multiple objects.</p>
	<p>Search column. Input key words, click  to search the corresponding information.</p>
	<p>Text column. Input number, letter, symbol and so on.</p>
	<p>Close button. Click the icon to close the window.</p>

Table of Contents

Foreword	I
Important Safeguards and Warnings	III
1 Overview	1
1.1 Introduction	1
1.2 Login Mode	1
2 The Grand Tour	2
2.1 8-HDD Series	2
2.1.1 Front Panel	2
2.1.2 Rear Panel	3
2.1.3 Dimensions	4
2.2 12-HDD Series	5
2.2.1 Front Panel	5
2.2.2 Rear Panel	6
2.2.3 Dimensions	8
2.3 16-HDD Series	8
2.3.1 Front Panel	9
2.3.2 Rear Panel	10
2.3.3 Dimensions	12
2.4 24-HDD Series	13
2.4.1 Front Panel	13
2.4.2 Rear Panel	15
2.4.3 Dimensions	17
3 Hardware Installation	19
3.1 Installation Flow	19
3.2 Unpacking the Box	19
3.3 HDD Installation	19
3.3.1 12-HDD Series	20
3.3.2 16/24-HDD Series	20
3.4 Cable Connection	21
3.4.1 Alarm Connection	21
3.4.2 Connection Diagram	25
4 Starting IVSS	26
5 Initial Settings	27
5.1 Initializing Device	27
5.2 Quick Settings	30
5.2.1 Configuring IP Address	30
5.2.2 Configuring P2P Settings	32
5.3 Login	33
5.3.1 Logging in to PCAPP Client	33
5.3.2 Logging in to Local Interface	37
5.3.3 Logging in to Web Interface	39

5.4 Configuring Remote Device	40
5.4.1 Initializing Remote Device	40
5.4.2 Adding Remote Device	44
6 AI Operations	56
6.1 Overview	56
6.2 Face Detection	57
6.2.1 Enabling AI Plan	57
6.2.2 Configuring Face Detection	59
6.2.3 Live View of Face Detection	61
6.2.4 Face Search	64
6.3 Face Recognition	75
6.3.1 Configuration Procedure	75
6.3.2 Enabling AI Plan	75
6.3.3 Configuring Face Database	75
6.3.4 Configuring Face Recognition	89
6.3.5 Live View of Face Recognition	91
6.3.6 Face Search	95
6.4 People Counting	97
6.4.1 Enabling AI Plan	97
6.4.2 People Counting	97
6.4.3 Queuing Detection	99
6.4.4 Live View	101
6.5 Video Metadata	101
6.5.1 Enabling AI Plan	102
6.5.2 Configuring Video Metadata	102
6.5.3 Live View of Video Metadata	104
6.5.4 AI Search	108
6.6 IVS	117
6.6.1 Enabling AI Plan	117
6.6.2 Configuring IVS	118
6.6.3 Live View of IVS	122
6.6.4 IVS Search	125
6.7 Vehicle Recognition	126
6.7.1 Enabling AI Plan	127
6.7.2 Setting Vehicle Recognition	127
6.7.3 Live View of Vehicle Recognition	128
6.7.4 Searching for Detection Information	130
6.8 ANPR	130
6.8.1 Procedure	131
6.8.2 Enabling AI Plan	131
6.8.3 Configuring Vehicle Database	131
6.8.4 Configuring Number Plate Comparison	143
6.8.5 Live View of ANPR	145
6.8.6 AI Search	148
6.9 Crowd Distribution Map	151
6.9.1 Enabling AI Plan	151
6.9.2 Configuring Crowd Distribution Map	151

6.9.3 Live View of Crowd Distribution.....	153
7 General Operations	155
7.1 Live and Monitor.....	155
7.1.1 View Management.....	156
7.1.2 Resources Pool	174
7.1.3 PTZ	176
7.2 Recorded Files.....	180
7.2.1 Playing Back Recorded Video.....	180
7.2.2 Clipping Recorded Video.....	185
7.2.3 Playing Back Snapshots.....	186
7.2.4 Exporting File.....	189
7.2.5 Video Tag.....	191
7.2.6 Locking Files.....	192
7.3 Alarm List	193
7.4 Display Management	193
7.4.1 Multiple-screen Control.....	194
7.4.2 Locking Screen	195
7.5 System Info	195
7.6 Background Task.....	196
7.7 Buzzer	196
8 System Configuration	197
8.1 Configuration Interface.....	197
8.2 Device Management	198
8.2.1 Local Device	198
8.2.2 Remote Device	201
8.3 Network Management.....	221
8.3.1 Basic Network.....	222
8.3.2 Network Apps.....	230
8.4 Event Management.....	243
8.4.1 Alarm Actions	244
8.4.2 Local Device	249
8.4.3 Remote Device	256
8.5 Storage Management	262
8.5.1 Local Hard Disk	263
8.5.2 RAID	266
8.5.3 Network Hard Disk.....	273
8.6 Security Strategy.....	276
8.6.1 HTTPS	276
8.6.2 Configuring Access Permission.....	282
8.6.3 Safety Protection	284
8.6.4 Enabling System Service Manually	285
8.6.5 Configuring Firewall.....	286
8.6.6 Configuring Time Synchronization Permission.....	287
8.7 Account Management	288
8.7.1 User Group	288
8.7.2 Device User	291
8.7.3 Password Maintenance	293

8.7.4 ONVIF	299
8.8 System Configuration.....	302
8.8.1 Setting System Parameters.....	302
8.8.2 System Time	303
8.8.3 Display	305
8.8.4 Schedule	307
8.9 Cluster Service.....	308
8.9.1 Configuring Cluster	308
8.9.2 Record Synchronization	312
8.9.3 Viewing Cluster Log.....	313
8.10 Storage Management	314
8.10.1 Storage Mode	314
8.10.2 Record Control.....	317
8.10.3 Record Transfer	318
9 System Management.....	320
9.1 File Management	320
9.1.1 Video Tag Management.....	320
9.1.2 FILE LOCKED	321
9.1.3 Face Management.....	321
9.1.4 Vehicle Management	321
9.1.5 Voice Management.....	322
9.1.6 Watermark Verification.....	323
9.2 Task Management.....	324
9.3 Backup	327
9.4 AI Report	329
9.4.1 In-area People Counting Report.....	329
9.4.2 Queue People Counting Report	331
10 System Maintenance.....	333
10.1 Overview	333
10.2 System Resources.....	335
10.3 Logs.....	335
10.4 Intelligent Diagnosis.....	337
10.4.1 Run Log	337
10.4.2 One-click Export	337
10.5 Online User	338
10.6 Device Maintenance	339
10.6.1 Upgrading Device	339
10.6.2 Default.....	342
10.6.3 Automatic Maintenance	343
10.6.4 IMP/EXP	343
11 PCAPP Introduction	345
11.1 Interface Description	345
11.2 History Record.....	345
11.3 Viewing Downloads.....	346
11.4 Configuring PCAPP.....	346
11.5 Viewing Version Details.....	348
12 Log Out, Reboot, Shut Down, Lock.....	349

13 FAQ	351
Appendix 1 Mouse and Keyboard Operations	352
Appendix 1.1 Mouse Operations	352
Appendix 1.2 Virtual Keyboard	352
Appendix 2 RAID	355
Appendix 3 HDD Capacity Calculation	357
Appendix 4 Glossary.....	358
Appendix 5 Cybersecurity Recommendations	360

1 Overview

1.1 Introduction

As an intelligent video surveillance server (hereinafter referred to as IVSS or the Device), IVSS delivers not only the basic video surveillance functions, but also a bunch of advanced AI features including face recognition, perimeter protection, video metadata and ANPR, providing AI-based all-in-one surveillance solution for customers.

- General functions: Video surveillance, video storage, alarm, record search and playback, intelligent analysis features.
- User-friendly interface.
- 4K and H.265 decoding.
- Applicable to scenarios such as intelligent building, large parking lot, safe city project, financial planning area and more.

1.2 Login Mode

You can operate the device by using the local interface, web client and PCAPP client (the PC client, hereinafter referred to as PCAPP). For details, see Table 1-1.



Operation and system configuration in this manual is mainly based on PCAPP. There might be differences from local or web operation. The actual interface shall prevail.

Table 1-1 Login mode

Login Mode	Operation	Description
Local login	Connect the display, mouse and keyboard to the device. View and operate the local menu on the display.	Support all functions of the device.
Web login interface	Connect the device and PC into the same network, and remotely access the device through browser (Google Chrome and Firefox) on PC.	Support majority functions of the device, except live, record playback and video-related function.
Log in PCAPP	Connect the device and PC into the same network, download and install PCAPP on PC, and then remotely access the device with PCAPP.	Support all functions of the device.

2 The Grand Tour

This section introduces front panel, rear panel, port function and button function, indicator light status, and so on.

2.1 8-HDD Series

2.1.1 Front Panel

Figure 2-1 Front panel

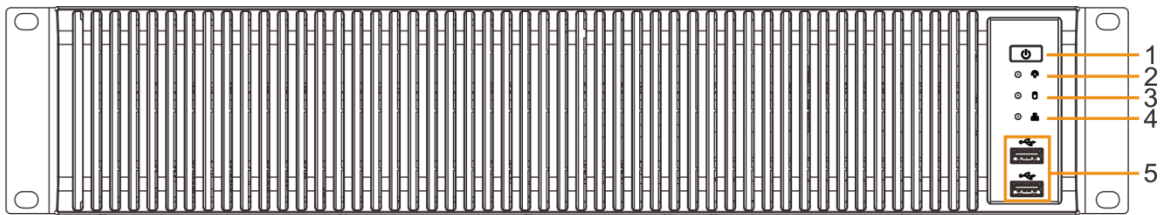


Table 2-1 Front panel description

No.	Button/Port	Description
1	Power	Boot up or shut down device. Power indicator light status is as follows: <ul style="list-style-type: none">• When device is off (indicator light is off), press the button for a short period to boot up device.• When device is running, (blue indicator light is on), press the button for at least 4 seconds to shut down the device.
2	Alarm indicator light	Displays local input alarm status. <ul style="list-style-type: none">• The indicator light is off: There is no local alarm input event.• Red indicator light is on: There is local alarm input event.
3	System status indicator light	Displays the system running status. <ul style="list-style-type: none">• The blue light is on: Device is running properly.• The indicator light is off: The device is not running.
4	Network indicator light	Displays current network status. <ul style="list-style-type: none">• The indicator light is blue: It means at least one Ethernet port has connected to the network.• The indicator light is off: No Ethernet ports are connected to the network.
5	USB	Connects to external devices such as USB storage device, keyboard and mouse.

2.1.2 Rear Panel

Figure 2-2 Rear panel

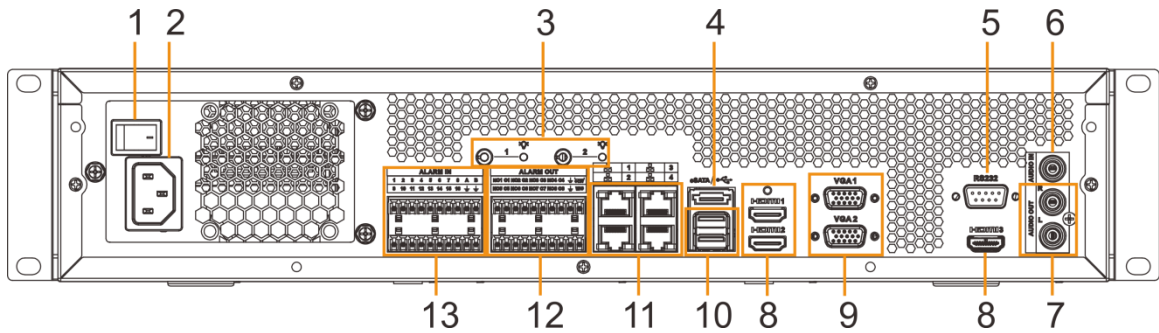





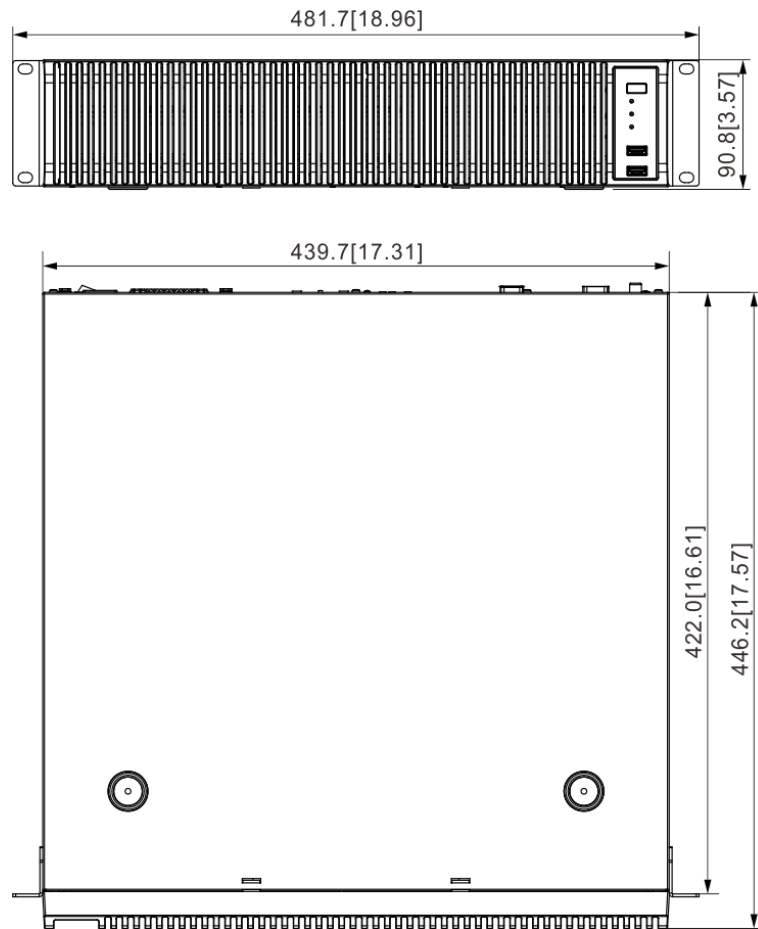
Table 2-2 Rear panel description

No.	Button/Port	Description
1	Power	Power on-off button.
2	Power input	Inputs AC 100V-AC240V power.
3	AI module indicator light	Displays AI module status. <ul style="list-style-type: none"> Yellow light flashes: AI module is running properly. Yellow light is on: AI module is malfunctioning.  <p>This function is not available without AI module.</p>
4	eSATA	SATA peripheral port. Connect to SATA port or eSATA device.
5	RS-232	RS-232 COM debug. It is for general COM debug, set IP address, transmit transparent COM data.
6	AUDIO IN	Audio input port.
7	AUDIO OUT	Audio output port.
8	HDMI	High definition audio and video signal output port. The port outputs the uncompressed high definition video and multi-channel audio data to the connected display with HDMI port. The three HDMI ports are different source output.
9	VGA	VGA video output port. Output analog video signal. It can connect to the monitor to view analog video. The two VGA ports are different source output. <ul style="list-style-type: none"> VGA1 and HDMI 1 are same source output. VGA2 and HDMI 2 are same source output.
10	USB	Connects to external devices such as USB storage device, keyboard and mouse.
11	Network	10M/100/1000Mbps self-adaptive Ethernet port. Connect to the network cable.
12	Alarm output	8 groups of alarm output ports (NO1 C1-NO8 C8). Output alarm signal to the alarm device. Please make sure there is power to the external alarm device. <ul style="list-style-type: none"> NO: Alarm output port of Normally Open type. C: Common alarm output port. : GND end.

No.	Button/Port	Description
13	Alarm input	<p>16 groups (1–16) alarm input ports, they are corresponding to ALARM 1–ALARM 16. The alarm becomes valid in low level.</p> <ul style="list-style-type: none"> A and B: Control the A/B cable of the RS–485 device. It is used to connect to the PTZ camera. Please parallel connect 120Ω between A/B cables if there are too many PTZ decoders. : GND end.

2.1.3 Dimensions

Figure 2-3 Dimension (Unit: mm [inch])



2.2 12-HDD Series

2.2.1 Front Panel

Figure 2-4 Front panel

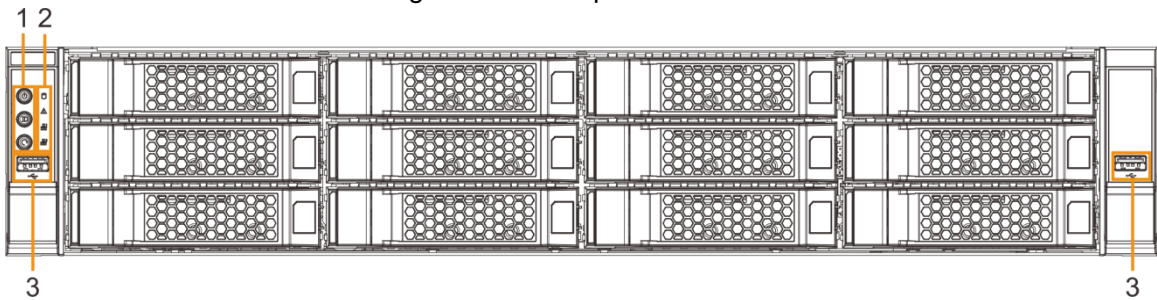



Table 2-3 Front panel description

No.	Button/Port	Description
1	Power	<p>Boot up or shut down device. Power indicator light status is as follows:</p> <ul style="list-style-type: none"> When device is off (indicator light is off), press the button for a short period to boot up device. When device is running, (blue indicator light is on), press the button for at least 4 seconds to shut down the device.
	ID button	<p>Position button. It is to used control the ID indicator light on the rear panel to position the device.</p>  <p>ID button has the indicator light function. Its display status is the same with the ID indicator light on the rear panel.</p>
	RESET button	Click to restart the device.
2	Power indicator light	<p>Displays power status.</p> <ul style="list-style-type: none"> Blue light is on: The device has properly connected to the power source. The indicator light is off: The device has not connected to the power source.
	Alarm indicator light	<p>Displays local alarm input status.</p> <ul style="list-style-type: none"> Green light on: There is no local alarm input alarm. Red indicator light is on: There is local alarm input event.
	Network indicator light 1	<p>Displays network statuses of Ethernet port 1 and Ethernet port 2.</p> <ul style="list-style-type: none"> The indicator light flashes green: At least one Ethernet port has connected to the network. The indicator light is off: All Ethernet ports are not connected to the network.
	Network indicator light 2	<p>Displays network statuses of Ethernet port 3 and Ethernet port 4.</p> <ul style="list-style-type: none"> The indicator light flashes green: At least one Ethernet port has connected to the network. The indicator light is off: All Ethernet ports are not connected to the network.
3	USB 3.0 port	Connects to external devices such as USB storage device, keyboard and mouse.

2.2.2 Rear Panel

Figure 2-5 Rear panel (the single-power series)

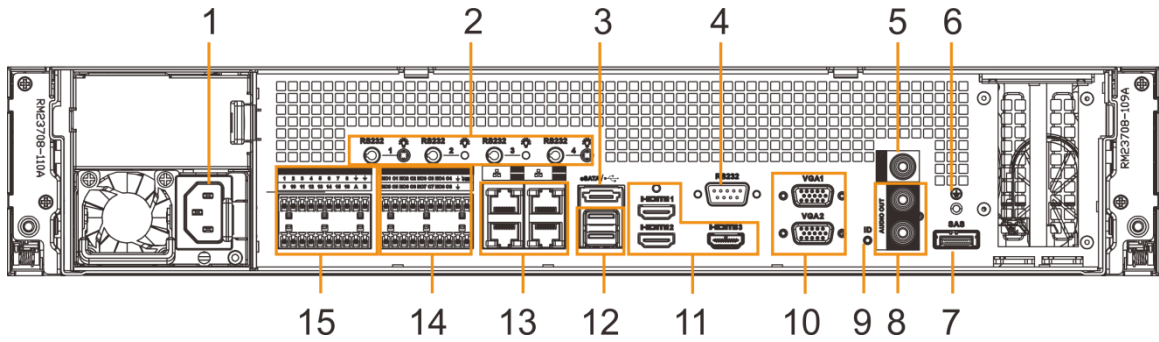


Figure 2-6 Rear panel (the redundant series)

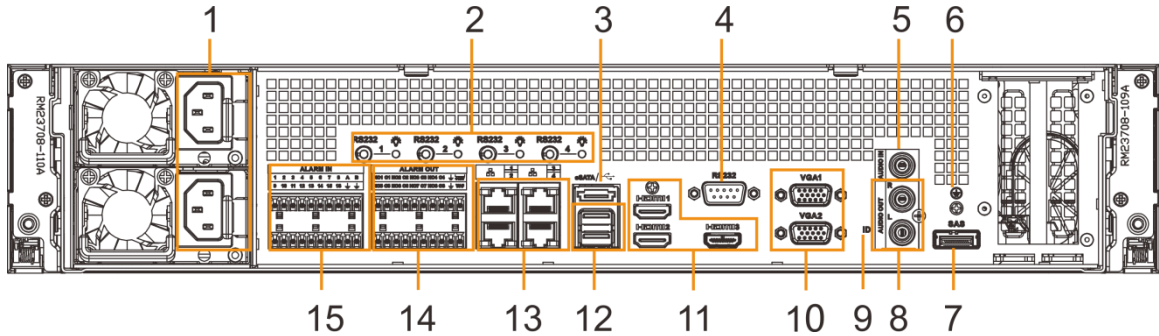





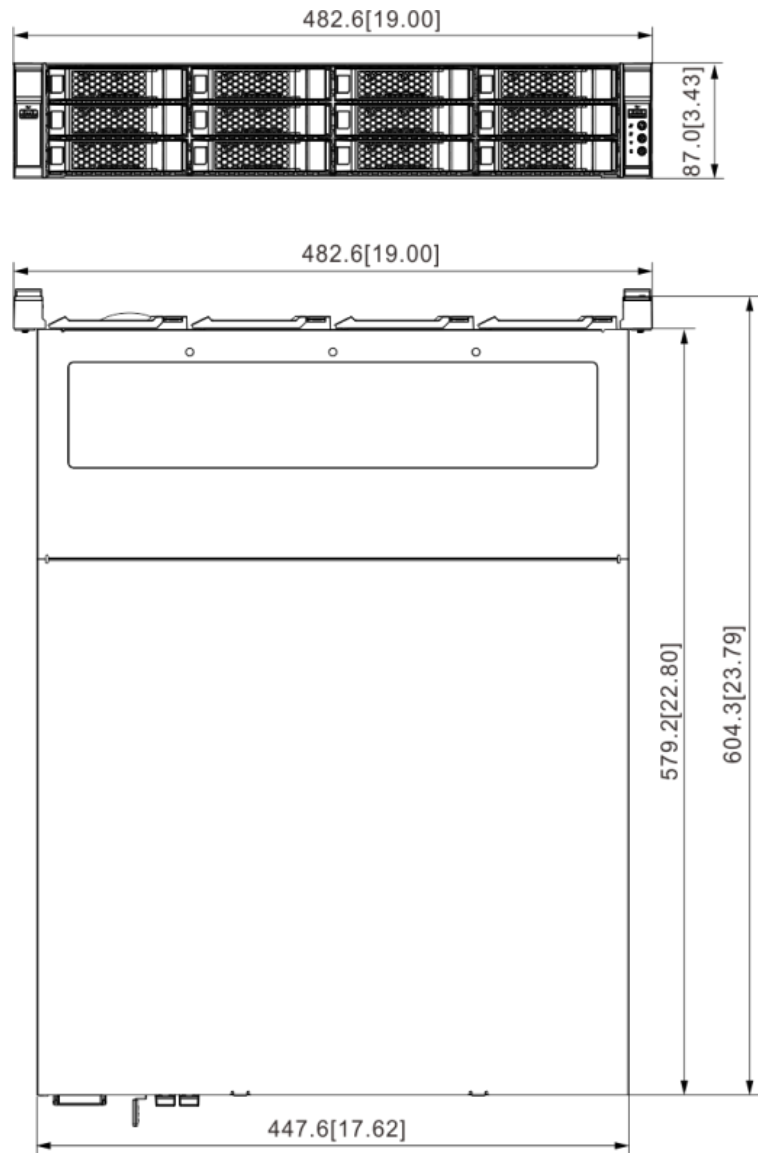
Table 2-4 Rear panel description

No.	Name	Description
1	Power input port	Inputs AC 100V-240V power.
2	AI module indicator light	Displays AI module status. <ul style="list-style-type: none"> The yellow light flashes: AI module is running properly. The yellow light is on: AI module is malfunctioning.  This function is not available without AI module.
3	eSATA port	SATA peripheral port. Connect to SATA port or eSATA device.
4	RS-232 port	RS-232 COM debug. It is for general COM debug, set IP address, transmit transparent COM data.
5	AUDIO IN	Audio input port
6	Ground port.	Ground port.
7	SAS port	SAS extension port. It can connect to the SAS extension controller.
8	AUDIO OUT	Audio output port
9	ID indicator light	Positioning indicator light. It is controlled by the ID button on the front panel. <ul style="list-style-type: none"> The blue light is on, device is positioning now. The indicator light is off: The device is not positioning.
10	VGA port	VGA video output port. Output analog video signal. It can connect to the monitor to view analog video. The two VGA ports are different source output. <ul style="list-style-type: none"> VGA1 and HDMI 1 are same source output. VGA2 and HDMI 2 are same source output.

No.	Name	Description
11	HDMI port	High definition audio and video signal output port. The port outputs the uncompressed high definition video and multi-channel audio data to the connected display with HDMI port. The three HDMI ports are different source output.
12	USB port	Connects to external devices such as USB storage device, keyboard and mouse.
13	Network port	10M/100/1000Mbps self-adaptive Ethernet port. Connect to the network cable.
14	Alarm output	8 groups of alarm output ports (NO1 C1–NO8 C8). Output alarm signal to the alarm device. Please make sure there is power to the external alarm device. <ul style="list-style-type: none"> • NO: Alarm output port of Normally Open type. • C: Common alarm output port. • : GND end.
15	Alarm input	16 groups (1–16) alarm input ports, they are corresponding to ALARM 1–ALARM 16. The alarm becomes valid in low level. <ul style="list-style-type: none"> • A and B: Control the A/B cable of the RS–485 device. It is used to connect to the PTZ camera. Please parallel connect 120Ω between A/B cables if there are too many PTZ decoders. • : GND end.

2.2.3 Dimensions

Figure 2-7 Dimensions (mm [inch])



2.3 16-HDD Series



- The Device has an embedded display on select models. The actual Device shall prevail.
- The Device has power redundancy on select models. The actual Device shall prevail.

2.3.1 Front Panel

Figure 2-8 Front panel with LCD

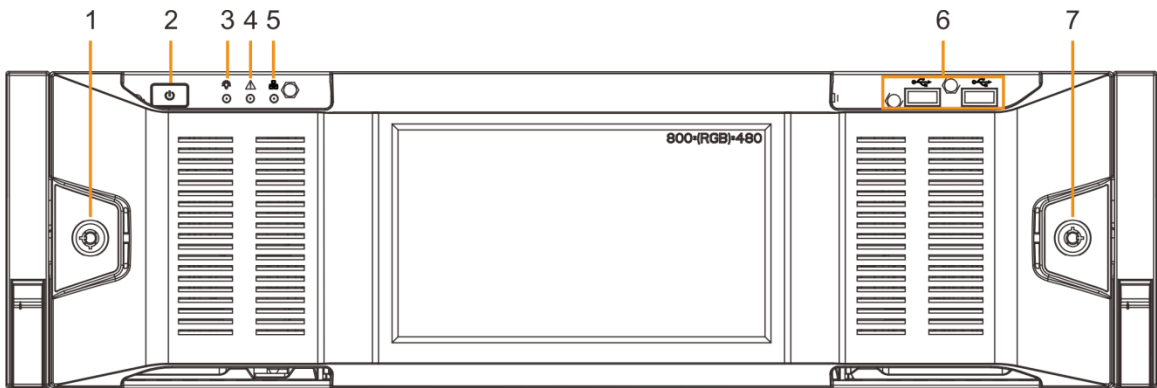


Figure 2-9 Front panel without LCD

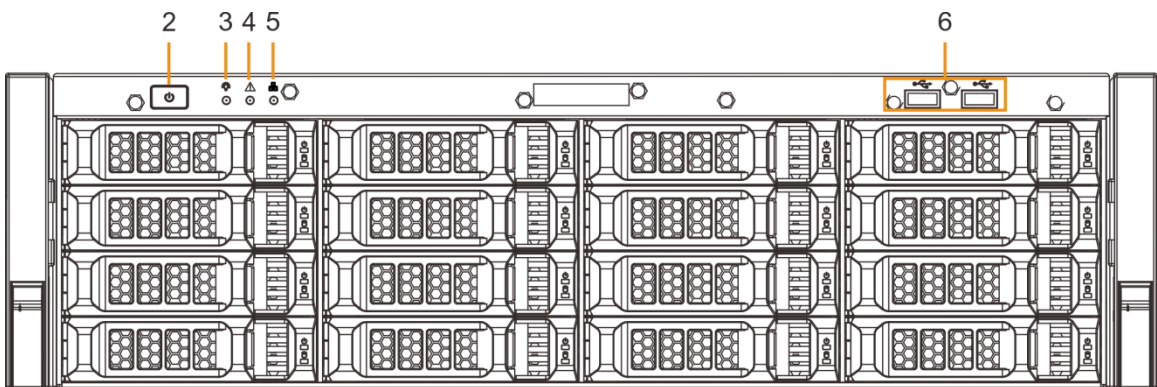




Table 2-5 Front panel description

No.	Button/Port	Description
1	Front panel lock	Once the front panel lock is secure, it can prevent HDD from being stolen or removed by mistake. Unlock the front panel lock and remove the front panel, you can view 16 HDD slots. See Figure 2-9.
2	Power	<p>Boot up or shut down device. The power on-off button has the indicator light. It can display device-running status.</p> <ul style="list-style-type: none"> When device is off (indicator light is off), press the button for a short period to boot up device. When device is running, (blue indicator light is on), press the button for at least 4 seconds to shut down the device.
3	System status indicator light	<p>Displays the system running status.</p> <ul style="list-style-type: none"> The blue light is on: Device is running properly. The indicator light is off: The device is not running.
4	Alarm indicator light	<p>Displays local input alarm status.</p> <ul style="list-style-type: none"> Red indicator light is on: There is local alarm input event. The indicator light is off: There is no local alarm input event.
5	Network indicator light	<p>Displays current network status.</p> <ul style="list-style-type: none"> The indicator light is blue: It means at least one Ethernet port has connected to the network. The indicator light is off: No Ethernet ports are connected to the network.

No.	Button/Port	Description
6	USB port	Connects to external devices such as USB storage device, keyboard and mouse.
7	16-HDD slot	<p>After you remove the front panel, you can see there are 16 HDDs. From the left to the right and from the top to the bottom, it ranges from 1–4, 5–8, 9–12, and 13–16.</p> <p>There are two indicator lights on the HDD slot: HDD indicator light and HDD read/write indicator light.</p> <ul style="list-style-type: none"> : HDD indicator light. The light is yellow after you install the HDD. : Read/write indicator light. The blue light flashes when it is reading and writing data.

2.3.2 Rear Panel

Figure 2-10 Rear panel (the single-power series)

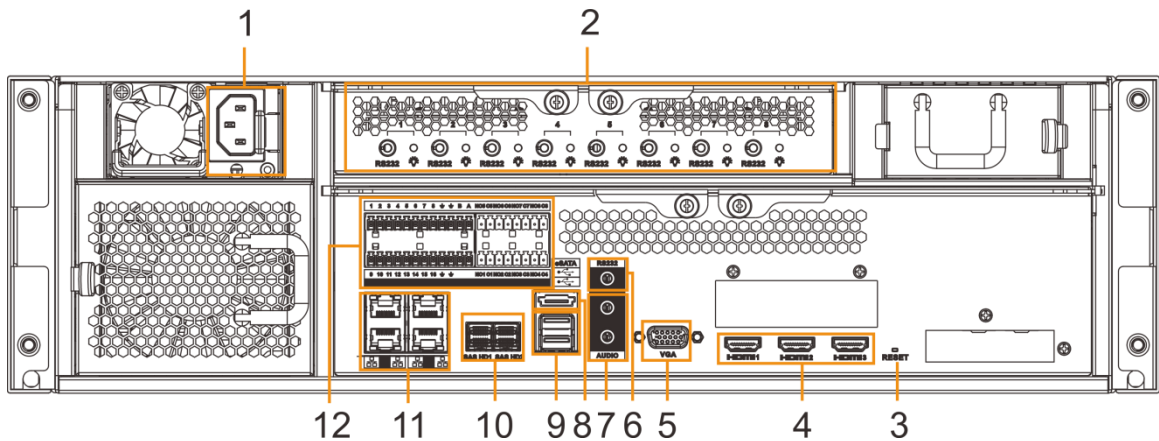


Figure 2-11 Rear panel (the redundant series)

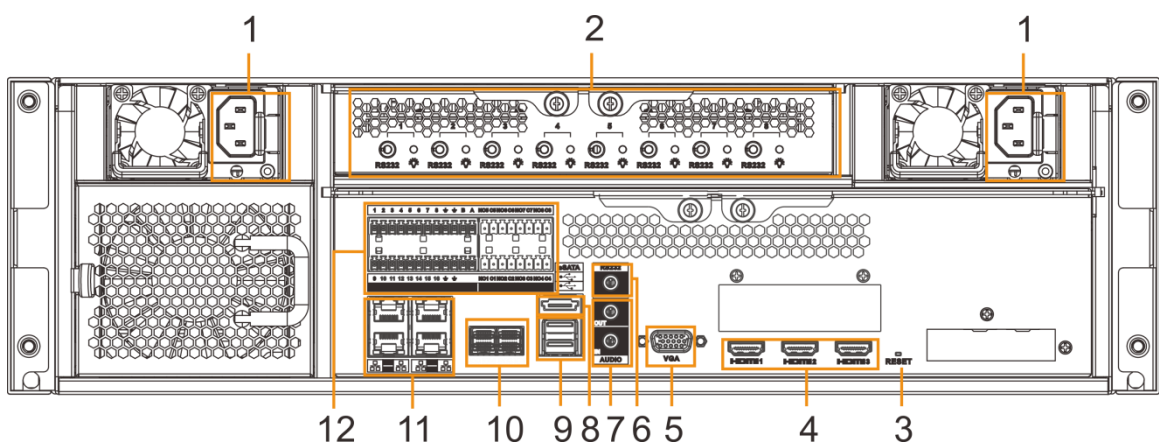





Table 2-6 Rear panel description

No.	Name	Description
1	Power input port	Inputs AC 100V-240V power.

No.	Name	Description
2	AI module indicator light	<p>Displays AI module status.</p> <ul style="list-style-type: none"> The yellow light flashes: AI module is running properly. The yellow light is on: AI module is malfunctioning.  <p>This function is valid if there is AI module.</p>
3	RESET button	Reserved.
4	HDMI port	<p>High definition audio and video signal output port.</p> <p>The port outputs the uncompressed high definition video and multi-channel audio data to the connected display with HDMI port. The three HDMI ports are different source output.</p>
5	VGA port	VGA video output port. Output analog video signal. It can connect to the monitor to view analog video. The VGA port and HDMI 1 port are same source output.
6	RS-232 port	RS-232 COM debug. It is for general COM debug, set IP address, transmit transparent COM data.
7	AUDIO IN	Audio input port
	AUDIO OUT	Audio output port
8	eSATA port	SATA peripheral port. Connect to SATA port or eSATA device.
9	USB port	Connects to external devices such as USB storage device, keyboard and mouse.
10	SAS port	SAS extension port. It can connect to the SAS extension controller.
11	Network port	10M/100/1000Mbps self-adaptive Ethernet port. Connect to the network cable.
12	Alarm Input	<p>16 groups (1–16) alarm input ports, they are corresponding to ALARM 1–ALARM 16. The alarm becomes valid in low level.</p> <ul style="list-style-type: none"> A and B: Control the A/B cable of the RS–485 device. It is used to connect to the PTZ camera. Please parallel connect 120Ω between A/B cables if there are too many PTZ decoders. : GND end.
	Alarm Output	<p>8 groups of alarm output ports (NO1 C1–NO8 C8). Output alarm signal to the alarm device. Please make sure there is power to the external alarm device.</p> <ul style="list-style-type: none"> NO: Alarm output port of Normally Open type. C: Common alarm output port. : GND end.

2.3.3 Dimensions

Figure 2-12 Dimensions with LCD (mm [inch])

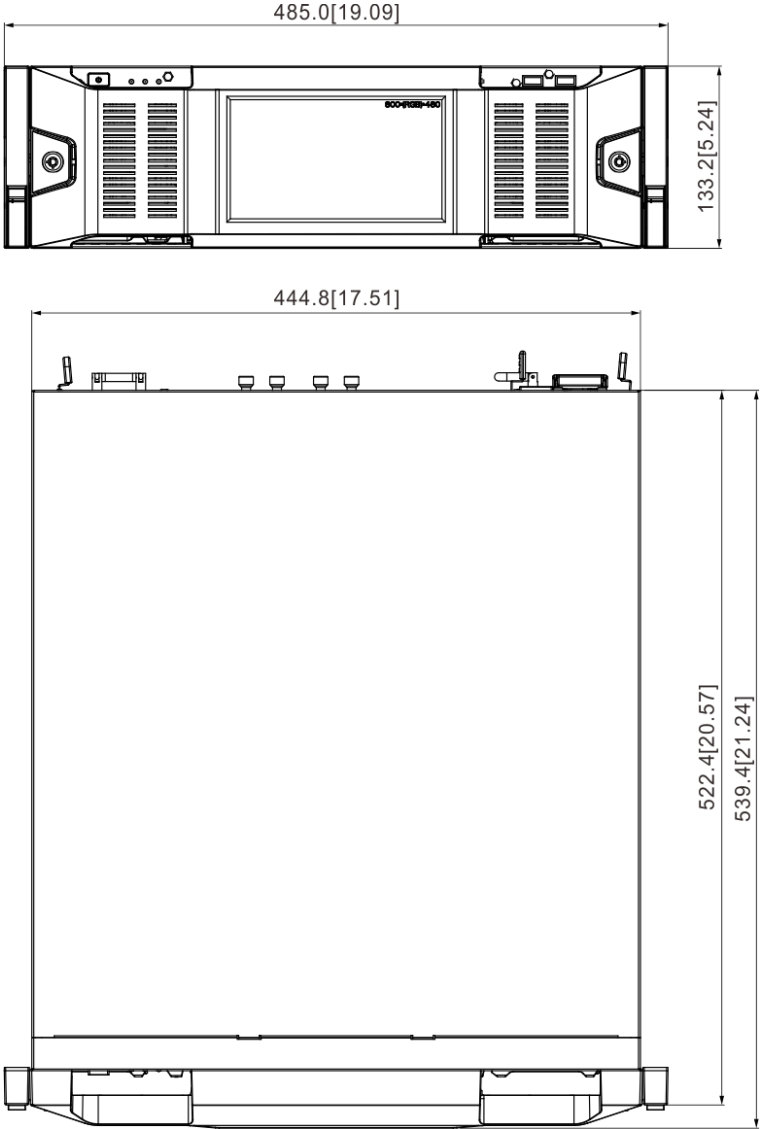
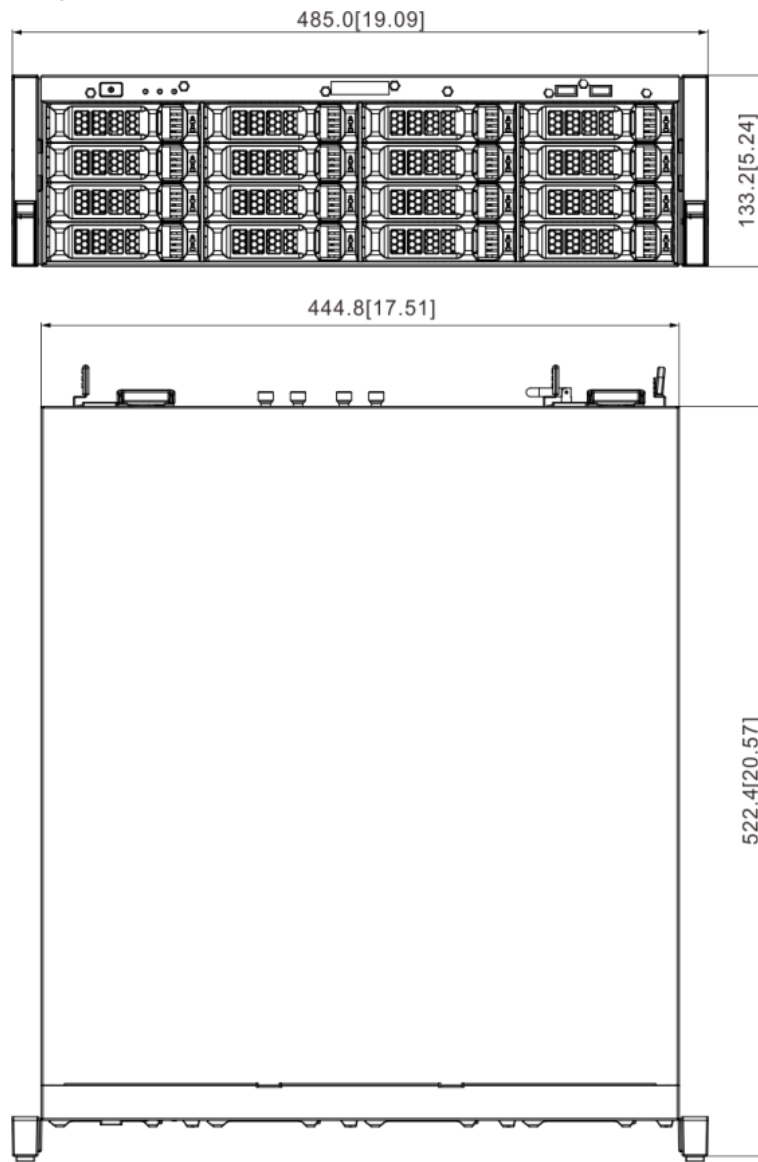


Figure 2-13 Dimensions without LCD (mm [inch])



2.4 24-HDD Series

2.4.1 Front Panel

Figure 2-14 Front panel with LCD

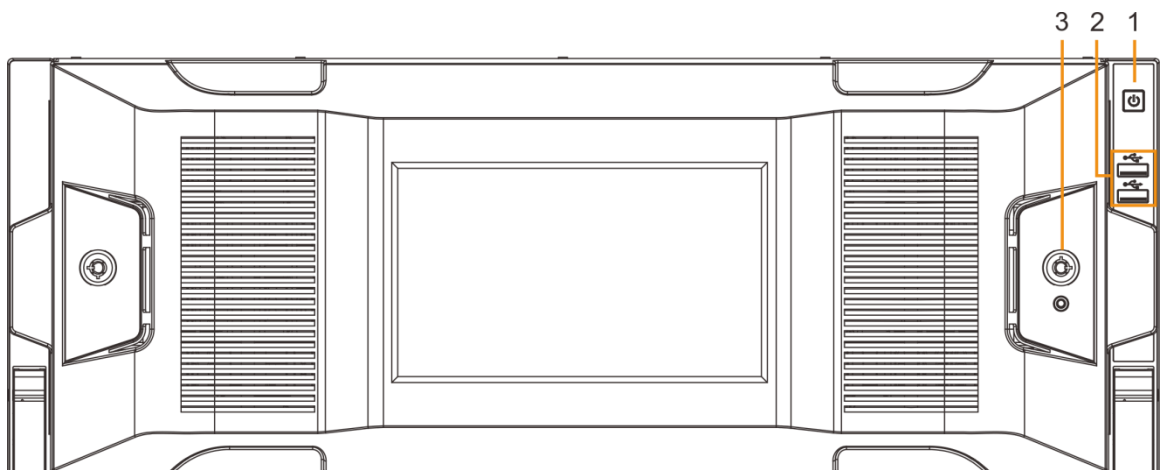


Figure 2-15 Front panel without LCD

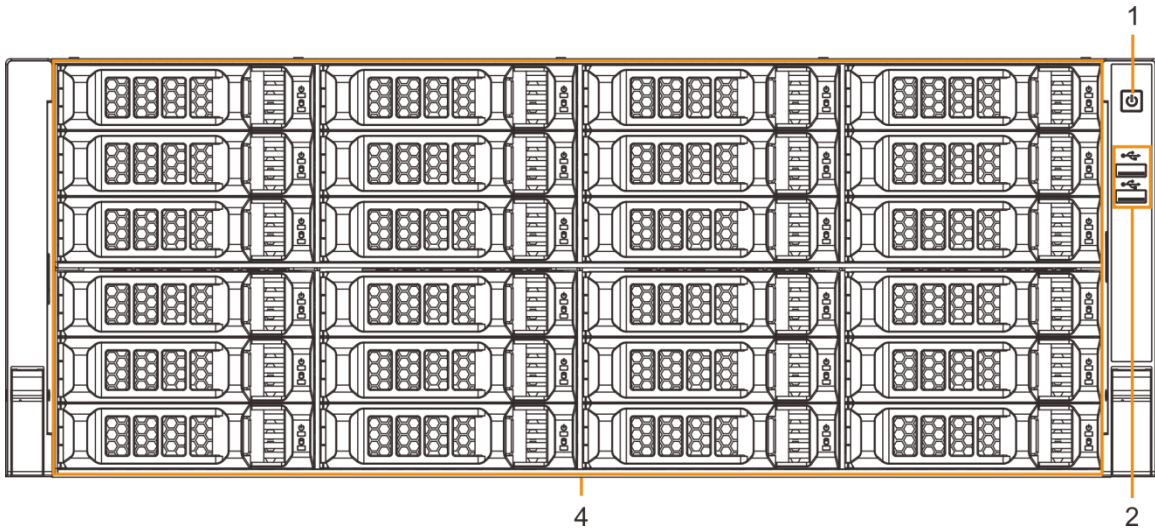




Table 2-7 Front panel description

No.	Button/Port	Description
1	Power on-off button	<p>Boot up or shut down device. The power on-off button has the indicator light. It can display device-running status.</p> <ul style="list-style-type: none"> When device is off (indicator light is off), press the button for a short period to boot up device. When device is running, (blue indicator light is on), press the button for at least 4 seconds to shut down the device.
2	USB port	Connects to external devices such as USB storage device, keyboard and mouse.
3	Front panel lock	Once the front panel lock is secure, it can prevent HDD from being stolen or removed by mistake. Unlock the front panel lock and remove the front panel, you can view 16 HDD slots. See Figure 2-15.
4	24-HDD slot	<p>After you remove the front panel, you can see there are 24 HDDs. From the left to the right and from the top to the bottom, it ranges from 1–4, 5–8, 9–12, 13–16, 17–20, and 21–24.</p> <p>There are two indicator lights on the HDD slot: HDD indicator light and HDD read/write indicator light.</p> <ul style="list-style-type: none"> : HDD indicator light. The light is yellow after you install the HDD. : Read/write indicator light. The blue light flashes when it is reading and writing data.

2.4.2 Rear Panel

Figure 2-16 Rear panel (the single-power series)

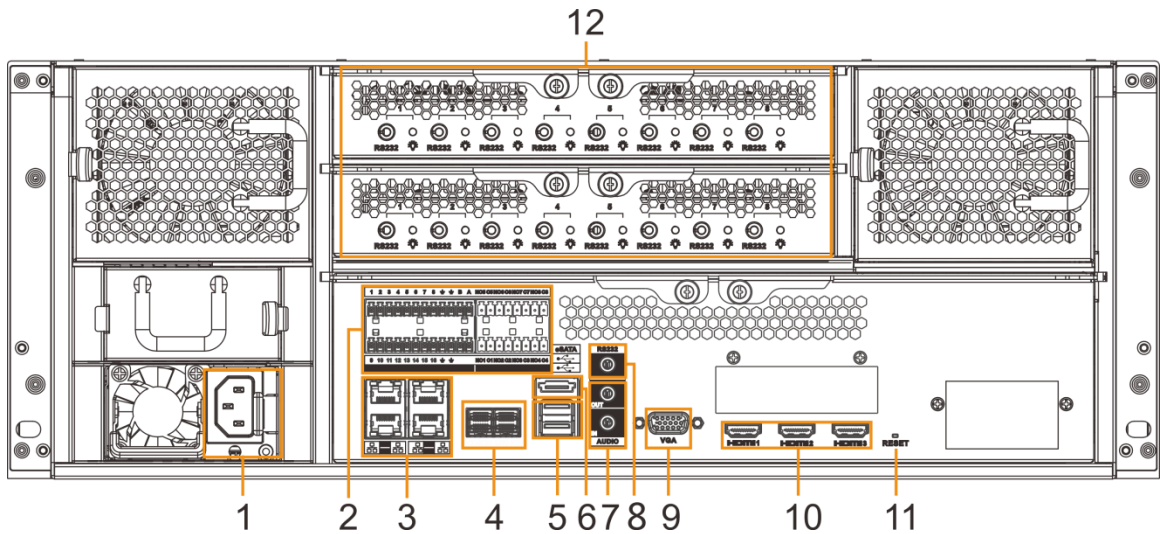


Figure 2-17 Rear panel (the redundant series)

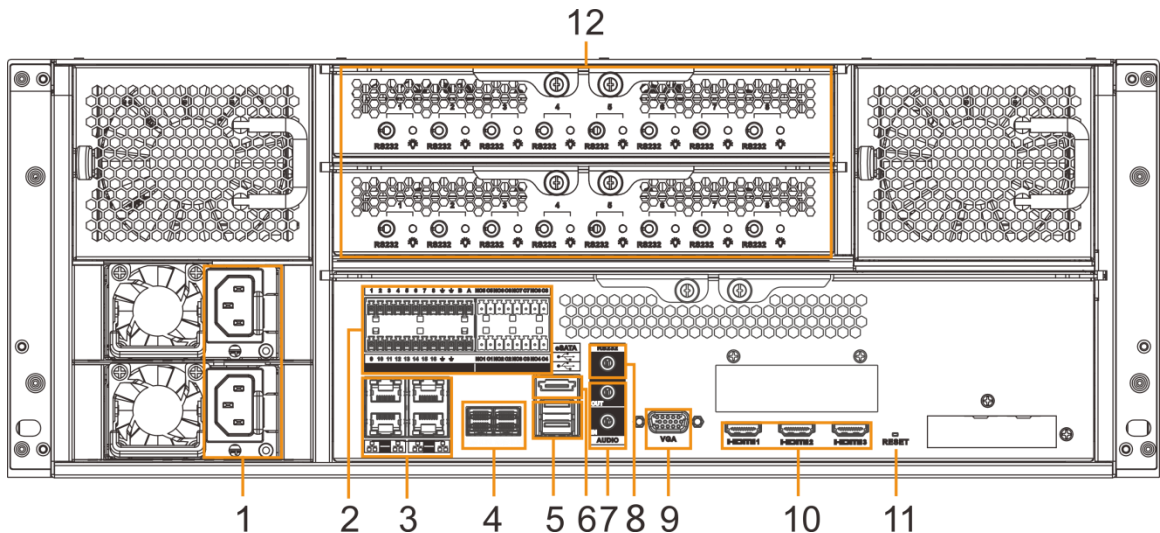




Table 2-8 Rear panel description

No.	Button/Port	Description
1	Power input port	Inputs AC 100V-240V power.
2	Alarm Input	<p>16 groups (1–16) alarm input ports, they are corresponding to ALARM 1–ALARM 16. The alarm becomes valid in low level.</p> <ul style="list-style-type: none"> • A and B: Control the A/B cable of the RS–485 device. It is used to connect to the PTZ camera. Please parallel connect 120Ω between A/B cables if there are too many PTZ decoders. • \perp: GND end.

No.	Button/Port	Description
	Alarm Output	<p>8 groups of alarm output ports (NO1 C1–NO8 C8). Output alarm signal to the alarm device. Please make sure there is power to the external alarm device.</p> <ul style="list-style-type: none"> • NO: Alarm output port of Normally Open type. • C: Common alarm output port. • : GND end.
3	Network port	10M/100/1000Mbps self-adaptive Ethernet port. Connect to the network cable.
4	SAS port	SAS extension port. It can connect to the SAS extension controller.
5	USB port	Connects to external devices such as USB storage device, keyboard and mouse.
6	eSATA port	SATA peripheral port. Connect to SATA port or eSATA device.
7	AUDIO IN	Audio input port
	AUDIO OUT	Audio output port
8	RS-232 port	RS-232 COM debug. It is for general COM debug, set IP address, transmit transparent COM data.
9	VGA port	VGA video output port. Output analog video signal. It can connect to the monitor to view analog video. The VGA port and HDMI 1 port are same source output.
10	HDMI port	High definition audio and video signal output port. The port outputs the uncompressed high definition video and multi-channel audio data to the connected display with HDMI port. The three HDMI ports are different source output.
11	RESET button	Reserved.
12	AI module indicator light	<p>Displays AI module status.</p> <ul style="list-style-type: none"> • The yellow light flashes: AI module is running properly. • The yellow light is on: AI module is malfunctioning.  <p>This function is not available without AI module.</p>

2.4.3 Dimensions

Figure 2-18 Dimensions with LCD (mm [inch])

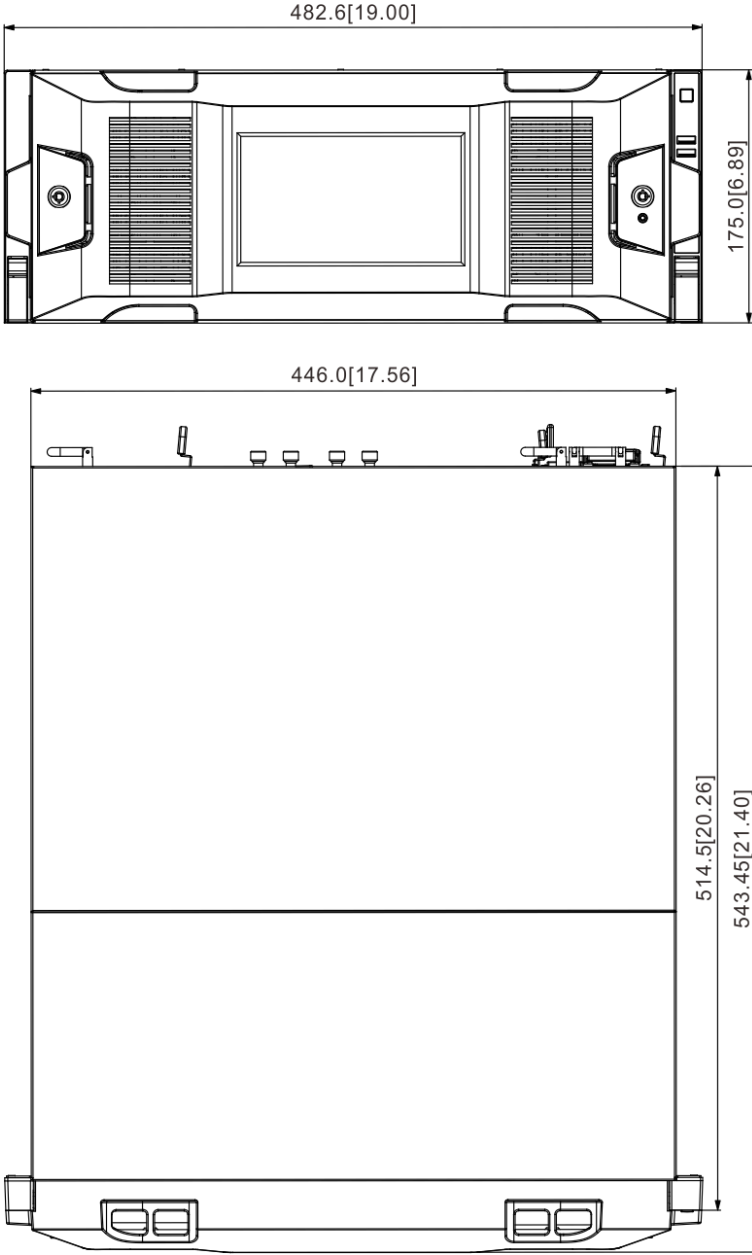
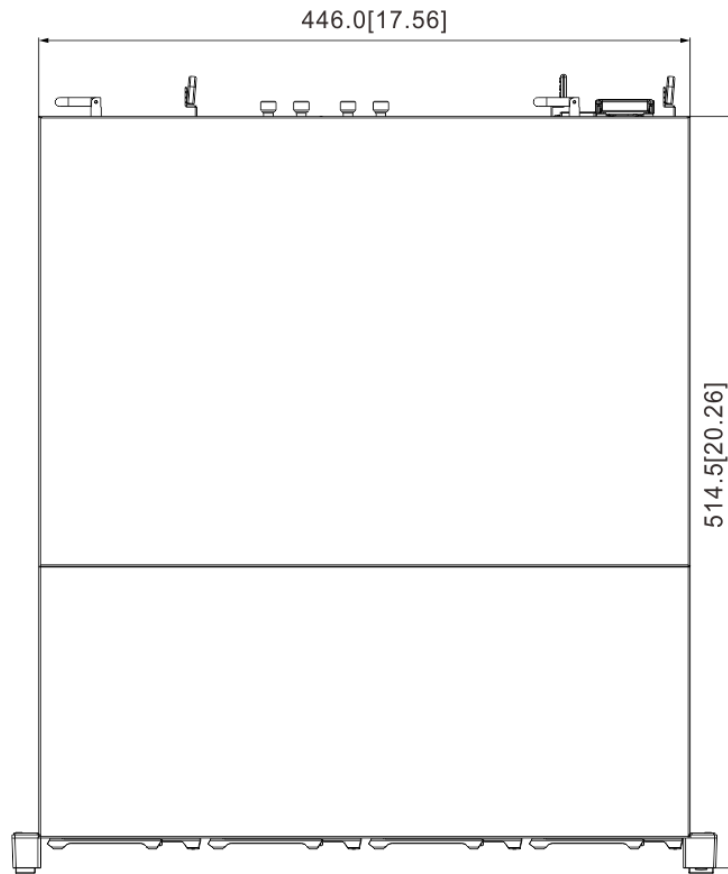
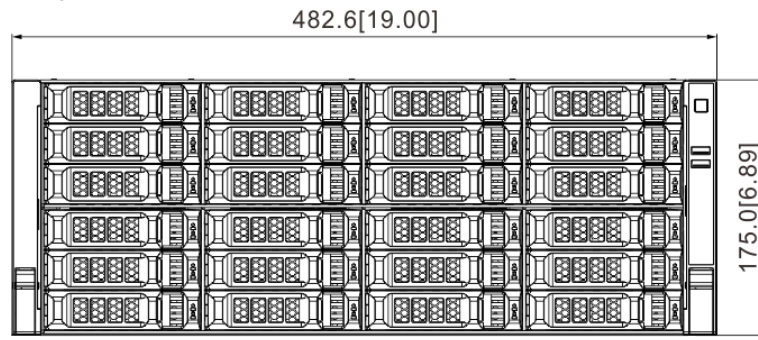


Figure 2-19 Dimensions without LCD (mm [inch])



3 Hardware Installation

This section introduces HDD installation, cable connection, and so on.

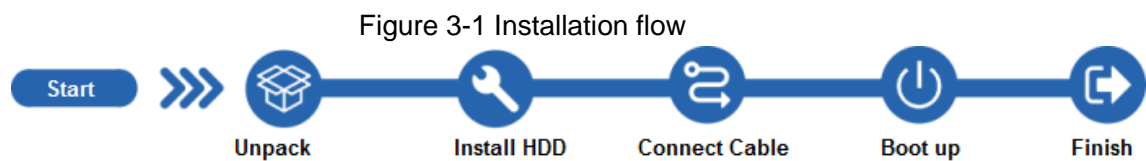


WARNING

Some series product is heavy. It needs several persons to carry or move, in order to prevent person injury.


3.1 Installation Flow

Follow Figure 3-1 to install the hardware.



3.2 Unpacking the Box

When you receive IVSS, please check against the following checking list. If any of the items are missing or damaged, contact the local retailer or after-sales engineer immediately.

No.	Button/Port	Content	
1	Whole package	Appearance	Check whether there is any visible damage.
		Package	Check whether there is any accidental clash during transportation.
		Accessories (list of accessories on the warranty card)	Check whether they are complete.
2	Device	Appearance	Check whether there is any visible damage.
		Device model	Check whether the model is the same as order contract.
		The label on the device	Check whether it is torn or not.  Do not tear off, or discard the label. Usually you need to show the serial number when we provide after-sales service.

3.3 HDD Installation

The section introduces the detailed operations to install HDD.



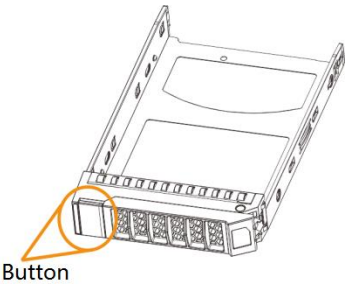
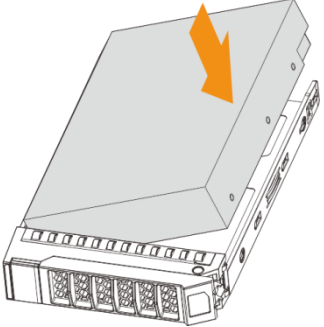
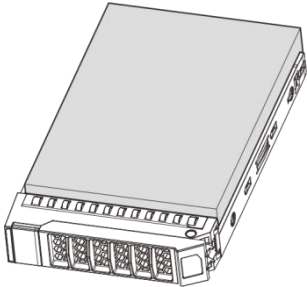
Different models support different HDD numbers, and the actual product shall prevail.

3.3.1 12-HDD Series

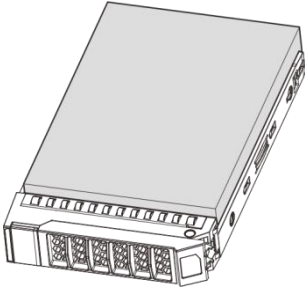
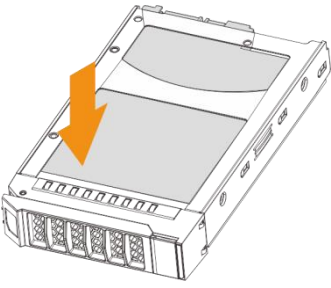
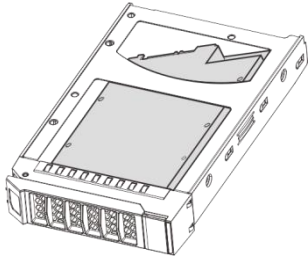


If you have not pushed the HDD box to the bottom, do not close the handle to avoid any damage to the HDD slot.

Installing HDD

 <p>Button</p>		
<p>① Press the button on the front panel of IVSS, open the handle, and then pull out the HDD box.</p>	<p>② Place one side of the HDD closely along the upper side of the box and press down to push the HDD down to the lower side of the mounting surface.</p>	<p>③ Insert the HDD box into the HDD slot, press it to the bottom, and then close the box handle.</p>

Removing HDD

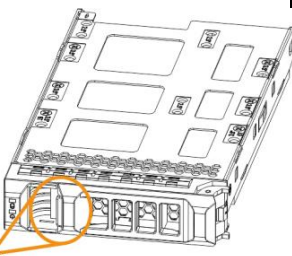
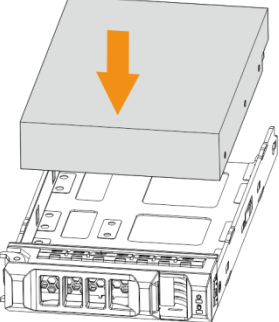
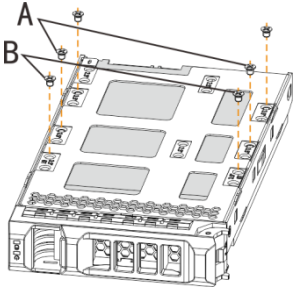

		
<p>① Press the button on the front panel of IVSS, open the handle, and then pull out the HDD box.</p>	<p>② On the back of the HDD box, press hard on the position indicated by the arrow.</p>	<p>③ Take out the HDD and reinsert the box to the slot. Push it to the bottom and close the box handle.</p>

3.3.2 16/24-HDD Series

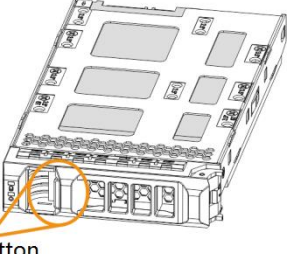
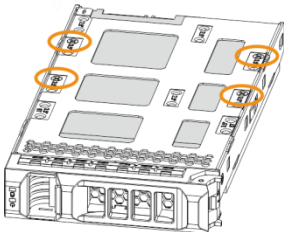
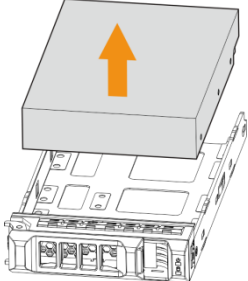



If you have not pushed the HDD box to the bottom, do not close the handle to avoid any damage to the HDD slot.

Installing HDD

 <p>Button</p>		
<p>① Press the button on the front panel of IVSS, open the handle, and then pull out the HDD box.</p>	<p>② Put the HDD into the box along the direction shown in the figure.</p>	<p>③ Lock the screws on the back of the HDD box. Insert the box into the HDD slot, push it to the bottom, and then close the handle.</p> <p></p> <p>In the figure, you only need to lock one set of the screws (Group A or Group B). See the actual situation.</p>

Removing HDD

 <p>Button</p>		
<p>① Press the button on the front panel of IVSS, open the handle, and then pull out the HDD box.</p>	<p>② Unlock the screws on the back of the HDD box.</p> <p></p> <p>The screws are at different positions for different HDDs, and the actual product shall prevail.</p>	<p>③ Take out the HDD and reinsert the box to the slot. Push it to the bottom and close the box handle.</p>

3.4 Cable Connection

The section introduces cable connection of IVSS.

3.4.1 Alarm Connection

Before using the alarm, connect alarm input or alarm output device.

3.4.1.1 Connection

The section introduces alarm connection of IVSS.

Alarm Input

- Both NO and NC are supported.
- The alarm input port supports alarm signal from ground and device of 12V-24V voltage.
- If the alarm device is connected to the Device and other devices, use relay for isolation.

Alarm Output

The alarm output port cannot be connected to high-power load (less than 1A). When forming output circuit, the excessive current should be prevented from causing damage to the relay. Use the contactor for isolation when applying high-power loads.

PTZ Decoder Connection

- The common-ground must be prepared for PTZ decoder and the Device; otherwise the common-mode voltage might not be able to control the PTZ. It is recommended to use shielded twisted pair, and the shielding layer can be used for common ground.
- Prevent interference from high-voltage power, make reasonable wiring, and take measures for lightning protection.
- Remotely import 120Ω to reduce resistance reflection and protect the signal quality.
- The Device A line and B line cannot connect to other RS-485 output device in parallel.
- The voltage between the A line and B line of PTZ decoder must be less than 5V.

Notes to Grounding

- Poor grounding of camera might damage the chip.
- When supplying external power source to the alarm device, the alarm device should be common-grounded with IVSS.

3.4.1.2 Alarm Port

For alarm port, see Figure 3-2 to Figure 3-4. For details, see Table 3-1.

Figure 3-2 Alarm port (8 HDD)

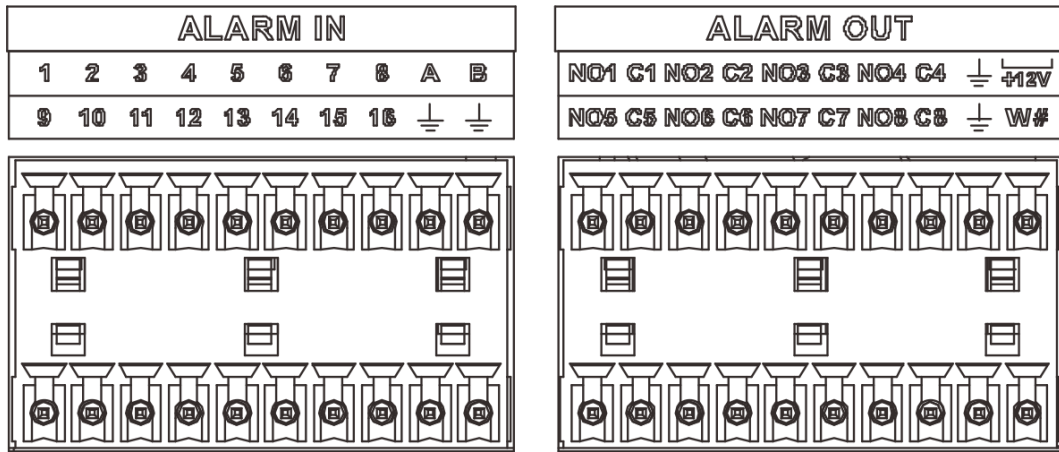


Figure 3-3 Alarm port (12 HDD)

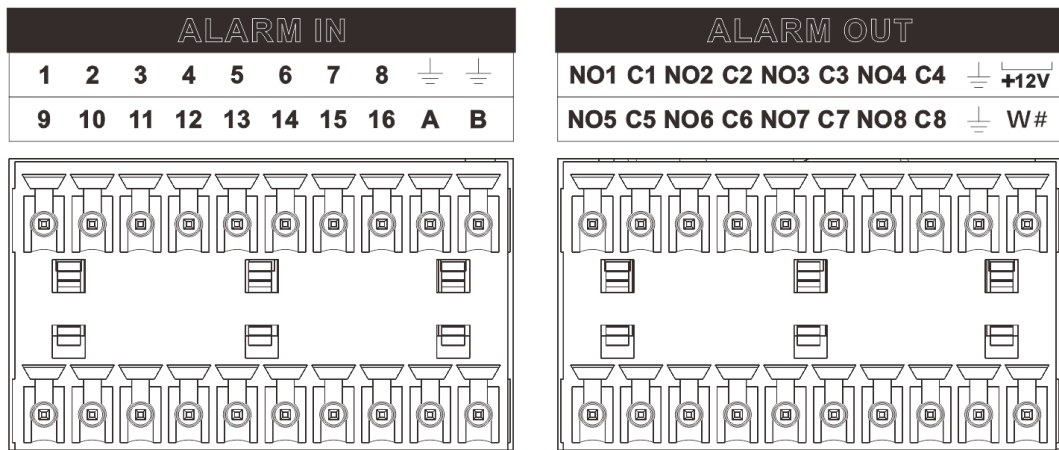


Figure 3-4 Alarm port (16 and 24-HDD)

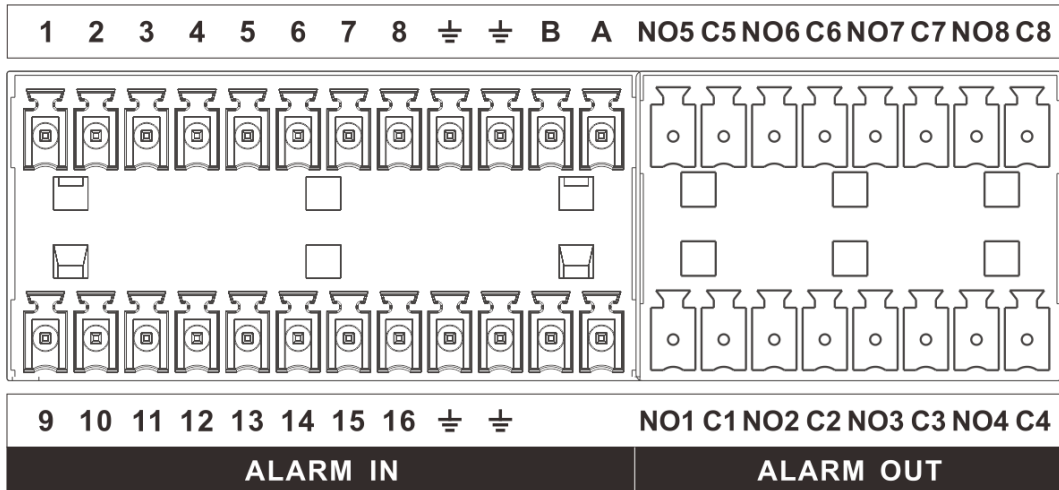


Table 3-1 Alarm port

Icon	Description
1–16	They are corresponding to ALARM 1–ALARM 16. The alarm becomes valid in low level.
NO1 C1–NO8 C8	Eight groups of normally open linkage output (on-off value)
+12V	Constant power output, 500mA current.
⏏	Grounding wire.
A, B	A and B: Control the A/B cable of the RS–485 device. It is used to connect to the PTZ camera. Please parallel connect 120Ω between A/B

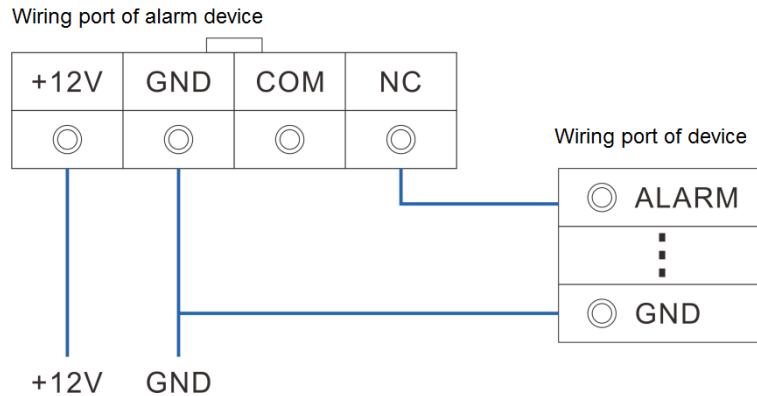
Icon	Description
	cables if there are too many PTZ decoders.

3.4.1.3 Alarm Input

Both NO and NC are supported. For connection of NC alarm input port, see Figure 3-5.

- GND and COM of alarm device shall be connected in parallel. Alarm device shall be powered with external power source.
- Connect GND of alarm device with GND of Device in parallel.
- Connect the NC port of alarm device to the alarm input port (1–16).

Figure 3-5 NC alarm input connection



3.4.1.4 Alarm Output

- The alarm output is on-off output (Normally Open Contact), and there should be external power supply to alarm output device.
- RS-485 A line and B line: connecting the A line and B line on the PTZ decoder.
- To avoid overload from damaging the Device, see the parameters about relay. For details, see Table 3-2.

Table 3-2 Relay parameters of alarm output port

Model		HRB1-S-DC5V
Contact material		Silver
Rated value (resistance load)	Rated power capacity	24V DC 2A, 125V AC 2A
	Maximum power	62.5VA/30W
	Maximum power voltage	125V AC, 60V DC
	Maximum power current	2A
Insulation	Between contacts	1000V AC 1 minute
	Between contact and loop	400V AC 1 minute
Insulation voltage		1000MΩ (500V DC)
Turn-on Time		<5ms
Turn-off Time		<5ms

Model		HRB1-S-DC5V
Life	Mechanical	300 times/1 minute
	Electrical	30 times/1 minute
Operating ambient temperature		-30°C–70°C

3.4.2 Connection Diagram

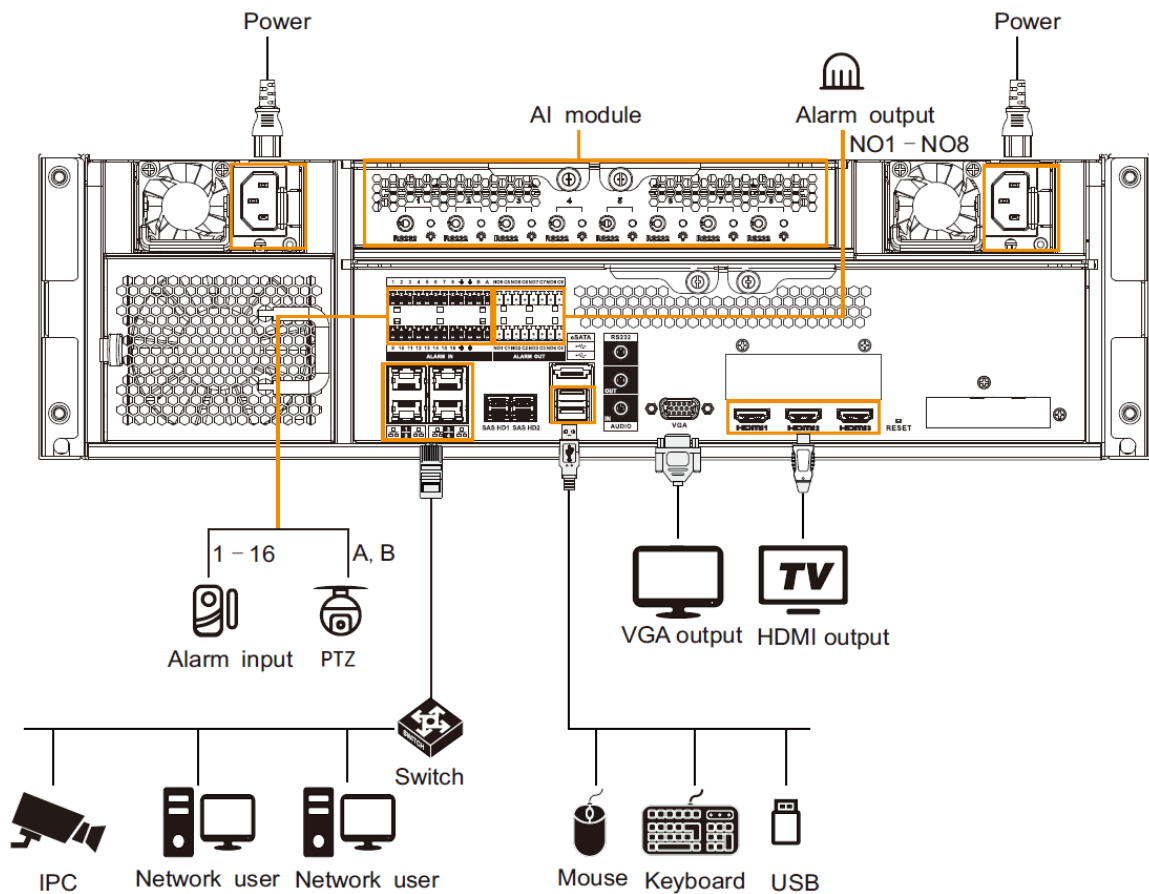


The following steps are to connect 16-HDD series device. See the actual product for detailed information.

For the device connection, see Figure 3-6. The following figure is for reference only. The actual product shall prevail.

- Display, mouse and keyboard are needed for local operation.
- Before using the smart detection functions such as face detection and face recognition, you shall install the AI module first.

Figure 3-6 Connection diagram



4 Starting IVSS



- Before starting the device, make sure that the input voltage shall match the device power requirement.
- To ensure stable operation of the device and prolong service life of HDD, provide stable voltage with less ripple interference by reference to international standard.
- For device security, connect other cables of the device first, and then connect the device to the power socket.

Boot-up might be different depending on the model you purchased.

- 8-HDD series IVSS: Press the power button on the rear panel to boot up device.
- For other series IVSS:
 - ◇ Connect to the power socket to boot up IVSS.
 - ◇ After clicking shutdown button on the GUI to shut down the device, press the power button for a short period of time to boot up the device.

5 Initial Settings

When using IVSS for the first time, initialize the device, and set basic information and functions first.

5.1 Initializing Device

If it is your first time to use the device after purchasing or after restoring factory defaults, set a login password of admin (system default user). At the same time, you can set proper password protection method.



Take web remote initialization for example.

Step 1 Open the browser, enter IP address, and then press **Enter**.



Default IP address of network port 1 to network port 4 are 192.168.1.108 to 192.168.4.108. Enter the corresponding IP address of the actually connected network port.

Step 2 On the **Language Set** interface, select a country or region, a language, and a language standard. Click **Next**. The language setting step is only available on the local interface of the Device.

The **Time** interface is displayed. See Figure 5-1.

Figure 5-1 Time setting

Device Initialization

1 Time 2 Input Password 3 Password Protection

Date
2019-11-04

Time
10:52:52

Time Zone
UTC+08:00 (Beijing, Greenwich)

Time
 Manual Setting
 Sync with Internet Time Server

Date/Time
2019-11-04 10:51:35


Server
clock.isc.org

Auto Sync Time Interval
1 hours

Next

Step 3 On the **Time** interface, set time parameters. For details, see Table 5-1.

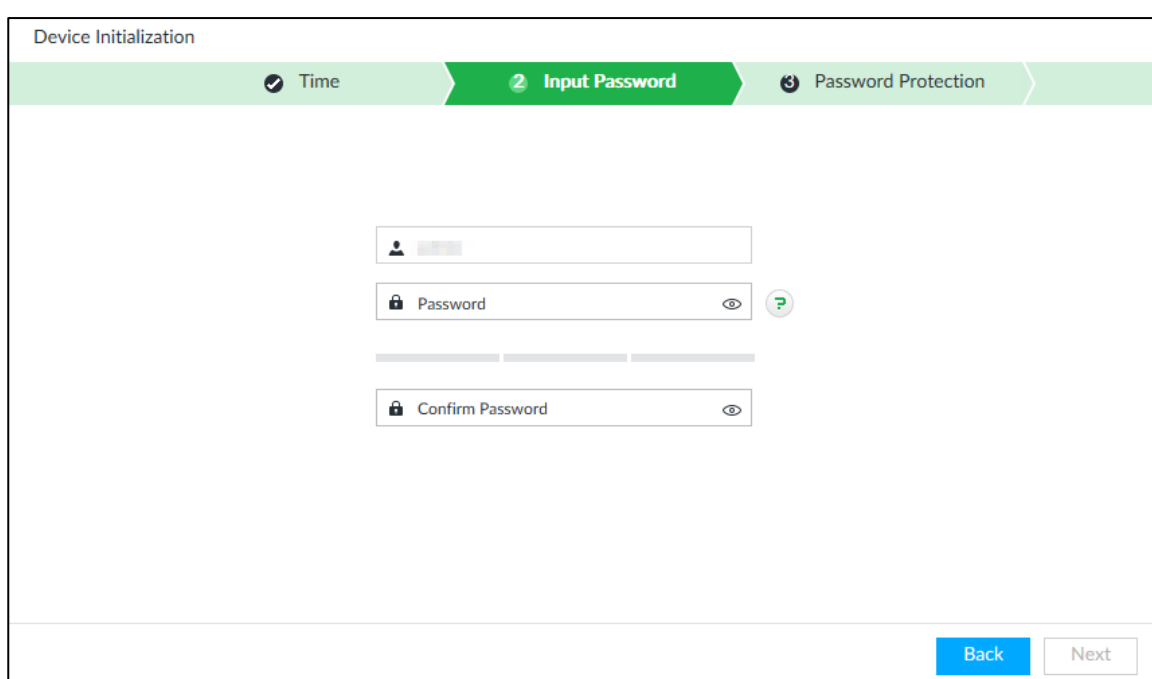
Table 5-1 Time parameters description

Parameters	Description
Time Zone	The time zone of the Device.
Time	<p>Set system date and time manually or by synchronizing with NTP server time.</p> <ul style="list-style-type: none"> Manual setting: Select date and time from the calendar. Sync with Internet Time Server: Select Sync with Internet Time Server, enter NTP server IP address or domain, and then set the automatic synchronization interval. <p> Device time will synchronize with the server time after Sync with Internet Time Server is set.</p>

Step 4 Click **Next**.

The **Input Password** interface is displayed. See Figure 5-2.

Figure 5-2 Set password



Step 5 Set admin login password. See Table 5-2.

Table 5-2 Description of password parameters

Parameters	Description
Username	The default user name is admin.
Password	Set admin login password, and confirm the password. The new password can be 8 characters to 32 characters in length and contains at least two types from number, letter and special characters (excluding ' " ; : & and space). Enter a strong password according to the password strength indication.
Confirm Password	

Step 6 Click **Next**.

The **Password Protection** interface is displayed. See Figure 5-3.

Figure 5-3 Password protection

Step 7 Set password protection information. For details, see Table 5-3. You can use the email you entered here or answer the security questions to reset admin password. See "8.7.3.2 Resetting Password" for detailed information.



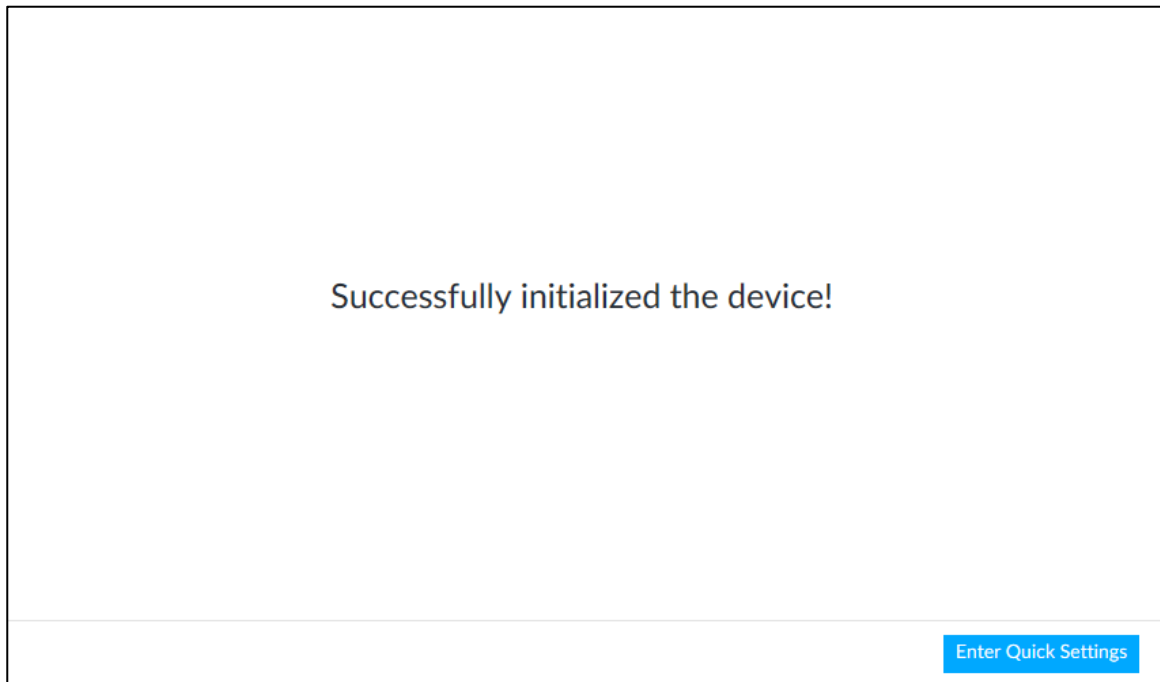
- Click to cancel the email or security questions.
- If the email or security questions are not set, the password can be reset on the local interface only.

Table 5-3 Password protection

Password protection mode	Description
Email	Leave an email address for resetting password.
Security question	Set security questions and corresponding answers. Reset the password through the security question.

Step 8 Click **Finish** to complete device initialization. The device initialization success interface is displayed. See Figure 5-4. Click **Enter quick settings** button to go to the quick setting interface, and then set device basic information. See "5.2 Quick Settings" for details.

Figure 5-4 Initialization completed



5.2 Quick Settings

After initializing the device, the system goes to quick settings interface. You can quickly set system time, IP address, and P2P.

5.2.1 Configuring IP Address

Configure device IP address, DNS server information and other information according to network planning.



Device has 4 Ethernet ports by default. Make sure that at least one Ethernet port has been connected to the network before you set IP address.

Step 1 On the completion interface of initialization, click **Enter Quick Setting**.

The **IP Set** interface is displayed. See Figure 5-5.

Figure 5-5 IP setting

Quick Configuration

1 IP Set P2P Access

NIC	NIC Type	Dhcp	IP Address	Subnet Mask	Mac	Speed	Operate
Ethernet Netw...	Electric Port	No	192.168.1.1	255.255.255.0	00:00:00:00:00:00	10M/100M/1000...	
Ethernet Netw...	Electric Port	No	192.168.1.2	255.255.255.0	00:00:00:00:00:00	10M/100M/1000...	
Ethernet Netw...	Electric Port	No	192.168.1.3	255.255.255.0	00:00:00:00:00:00	10M/100M/1000...	
Ethernet Netw...	Electric Port	No	192.168.1.4	255.255.255.0	00:00:00:00:00:00	10M/100M/1000...	

DNS Server IP Type: IPV4

Obtain DNS server address automatically

Use the following DNS server address

Preferred DNS: [. . .]

Alternate DNS: [. . .]

Default NIC Default Ethernet: Ethernet Network1

Next

Step 2 Configure IP address.

- 1) Click of the corresponding NIC.

The **Edit Ethernet Network 1** interface is displayed. See Figure 5-6.

Figure 5-6 Edit Ethernet network

Edit Ethernet Network1

Speed: 1000 Mb/s

IP Type: IPV4

Use Dynamic IP Address

Use Static IP Address

Static IP Address: [. . .]

Subnet Mask: [. . .]

Gateway: [. . .]


MTU: 1500 (1500-7200)

OK Cancel

- 2) Set parameters. For details, see Table 5-4.

Table 5-4 TCP/IP parameters description

Parameters	Description
Speed	Current NIC max network transmission speed.
IP Type	Select IPv4 or IPv6.

Parameters	Description
Use dynamic IP address	When there is a DHCP server on the network, check Use Dynamic IP Address , system can allocate a dynamic IP address to the device. There is no need to set IP address manually.
Use static IP address	Check Use Static IP Address , and then set static IP address, subnet mask and gateway to set a static IP address for the device.
MTU	<p>Set NIC MTU value. The default setup is 1500 Byte.</p> <p>We recommend you to check the MTU value of the gateway first and then set the device MTU value equal to or smaller than the gateway value. It is to reduce the packets slightly and enhance network transmission efficiency.</p>  <p>Changing MTU value might result in NIC reboot, network offline and affect current running operation. Please be careful!</p>

3) Click **OK**.

Device goes back to **IP Set** interface.

Step 3 Set DNS server information.

You can select to get DNS server manually or enter DNS server information.



This step is compulsive if you want to use domain service.

- 1) Select an IP type for DNS server. You can select IPv4 or IPv6.
- 2) Select the way of setting DNS IP address.
 - ◇ Select **Obtain DNS server address automatically**, and then the Device can automatically get the DNS server IP address on the network.
 - ◇ Select **Use the following DNS server address**, and then enter the preferred DNS IP address and the alternate DNS IP address.

Step 4 Set default NIC.

Select default NIC from the drop-down list.



Make sure that the default NIC is online.

Step 5 Click **Next** to save settings.

5.2.2 Configuring P2P Settings

P2P is a peer to peer technology. You can scan the QR code to download cellphone APP without DDNS service or the port mapping or installing the transmission server. After register the device to the APP, you can view the remote video, playback record file and so on.

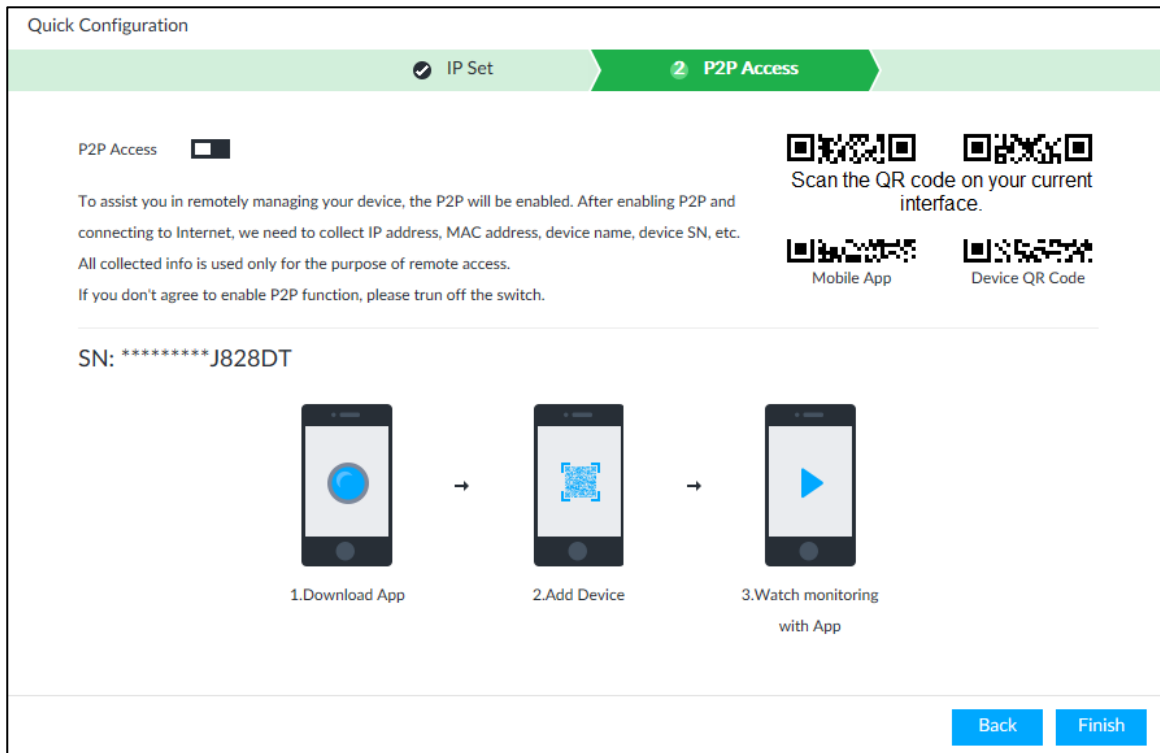


Make sure that the system has been connected to the network. Otherwise, the P2P function is null.

Step 1 On **IP Set** interface, click **Next**.

The **P2P Access** interface is displayed. See Figure 5-7. Scan the QR code on the actual interface.

Figure 5-7 P2P access



Step 2 Click to enable P2P function. The function is disabled by default.

Step 3 Click **Finish** to save settings.

After the configuration, you can register a device to the APP to view remote video, playback record file, and so on. See corresponding cellphone APP for detailed information.

5.3 Login

You can operate the device by using the local interface, web client and PCAPP.

- Display and mouse are needed for local operation.
- Remotely access with web and IPCAPP. PCAPP client is recommended.



After initializing the device, you have logged in by default. Now you can set system settings and operate.

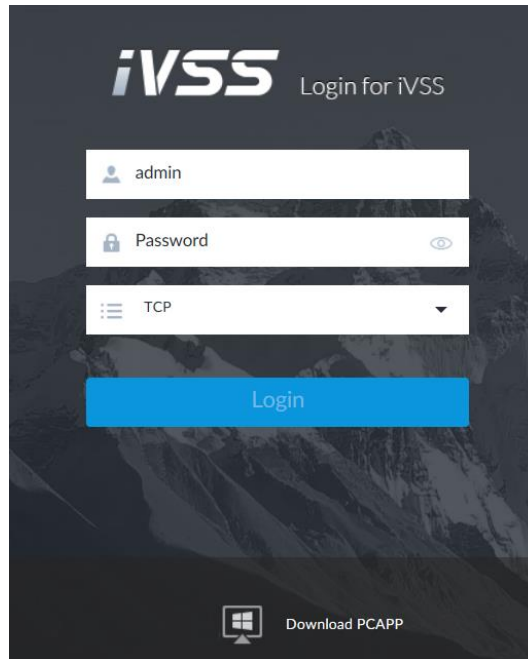
5.3.1 Logging in to PCAPP Client

Log in to the PCAPP for system configuration and operation.

Step 1 Download PCAPP.

- 1) Open the browser, enter IP address, and then press Enter. The web login interface is displayed. See Figure 5-8.

Figure 5-8 Web login interface



- 2) Click **Download PCAPP** to download PCAPP installation package.

Step 2 Install PCAPP.

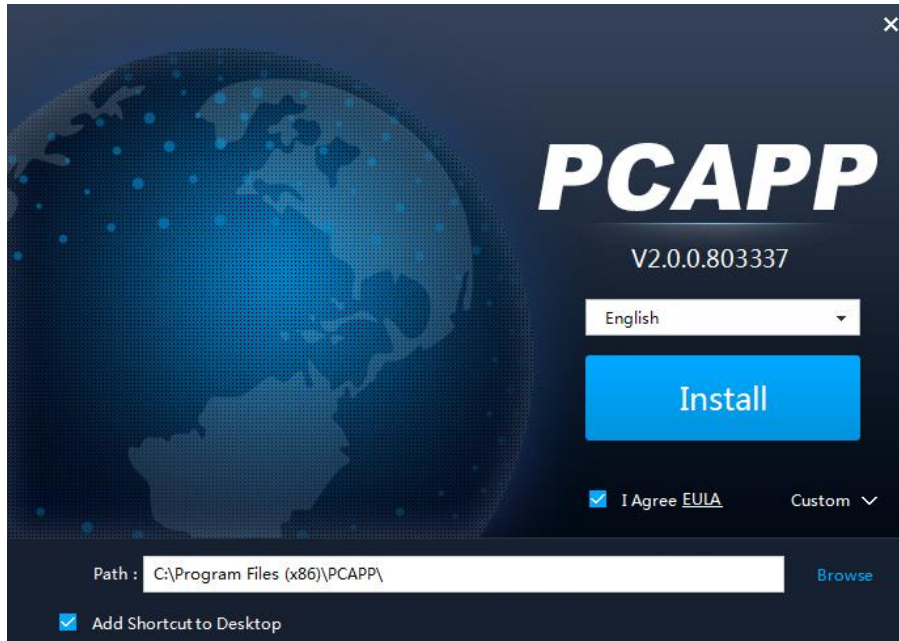
- 1) Double-click the installation package.
The installation interface is displayed. See Figure 5-9.

Figure 5-9 Installation interface



- 2) Select a language of the PCAPP.
- 3) Click **EULA**, read through the content, and then select the check box of **I Agree EULA**.
- 4) (Optional) Select installation path and create shortcut or not.
Click **Custom**. The installation path is displayed. See Figure 5-10. Select a path.

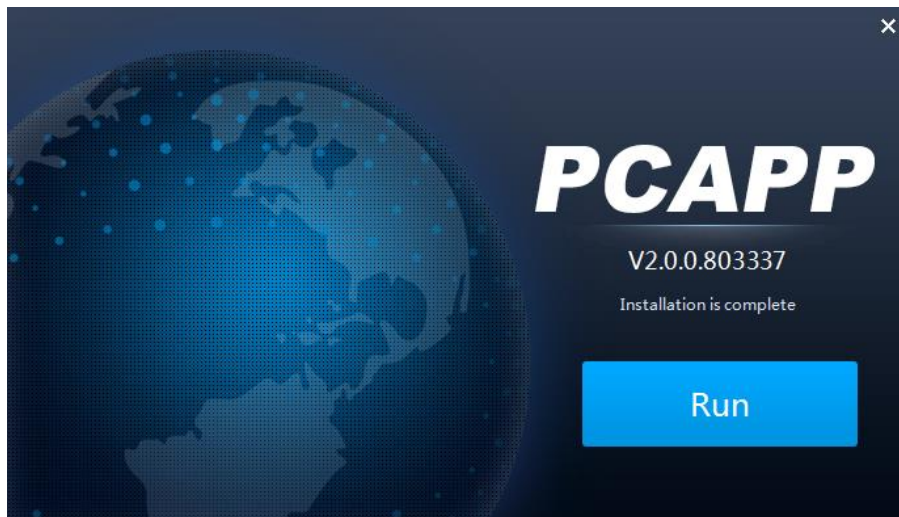
Figure 5-10 Custom installation




- 5) Click **Install**.

On completion, the completion interface is displayed. See Figure 5-11.

Figure 5-11 The installation is completed



Step 3 Log in to PCAPP.

- 1) There are two ways to enter PCAPP.
 - On the installation completion interface, click **Run**.
 - Double-click the shortcut icon  on the PC desktop.

The initial interface is displayed. See Figure 5-13.




- When PC theme is not Aero, the system will remind you to switch the theme. See Figure 5-12. To ensure video smoothness, switch your PC to Aero theme. For details, see "11.4 Configuring PCAPP."
- System display PCAPP at full-screen by default. Click  to display the task column. See Figure 5-13.

Figure 5-12 Prompt

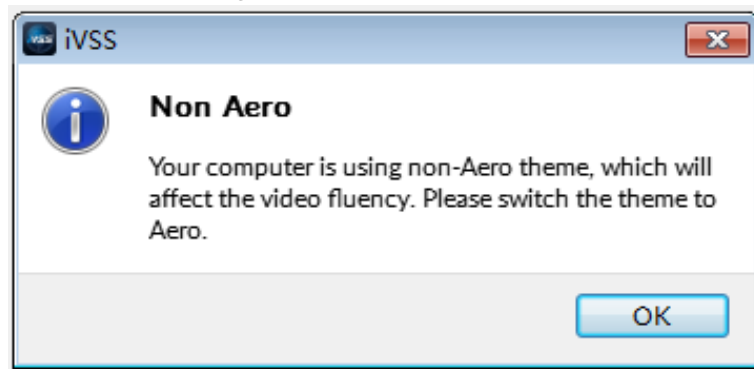



Figure 5-13 Initial interface



- 2) Enter device IP address, and then press **Enter** or click .

The login interface is displayed. See Figure 5-14.

Figure 5-14 Login



- 3) Enter device user name and password.



- Click **Login**. For your device safety, change the admin password regularly and keep it well.
- In case you forgot password, click **Forgot password** to reset. See "8.7.3.2 Resetting Password" for detailed information.

- 4) Select the login type among TCP, UDP and Multicast. Keep it TCP if you have no special requirement for TCP or UDP.

- 5) Click **Login**.

The **LIVE** interface is displayed. See Figure 5-15. For details, see Table 5-5.

Figure 5-15 Live view

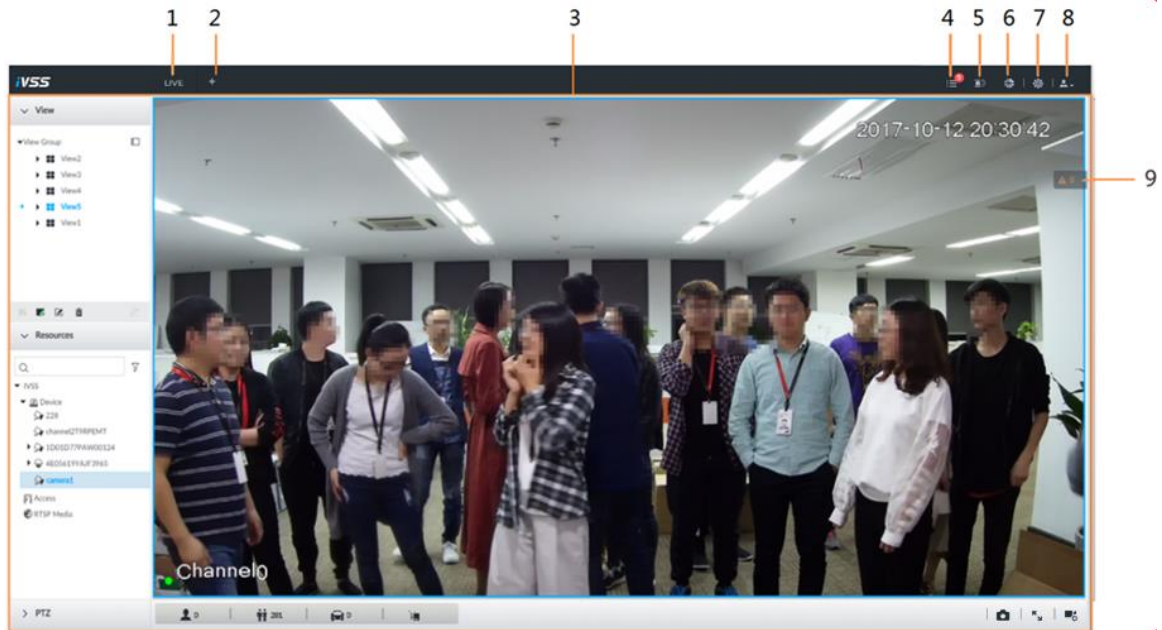





Table 5-5 Main interface description

No.	Name	Description
1	Task column	Displays enabled application icon. Move the mouse to the app and then click  to close the app.  The live function is enabled by default and cannot be closed.
2	Add icon	Click to display or hide app interface. On app interface to view or enable app.
3	Operation interface	Displays currently enabled app operation interface.
4	System Info	Click to view system information. See "7.5 System Info" for detailed information.
5	Buzzer	Click the icon to view buzzer messages. For details, see "7.7 Buzzer."
6	Background Task	Click to view the background running task information. See "7.6 Background Task" for detailed information.
7	System config	Click to enter system configuration mode. See "8 System Configuration" for detailed information.
8	Login user	Click it to change user password, lock user, logout user, reboot device or close device.
9	Alarm list	Click to view the unprocessed alarm event quantity. See "7.3 Alarm List" for detailed information.  Drag this icon to move its position.

5.3.2 Logging in to Local Interface

You can view the local interface of the Device by connecting a display to it, and then you can carry out local operation on the display.

Preparation

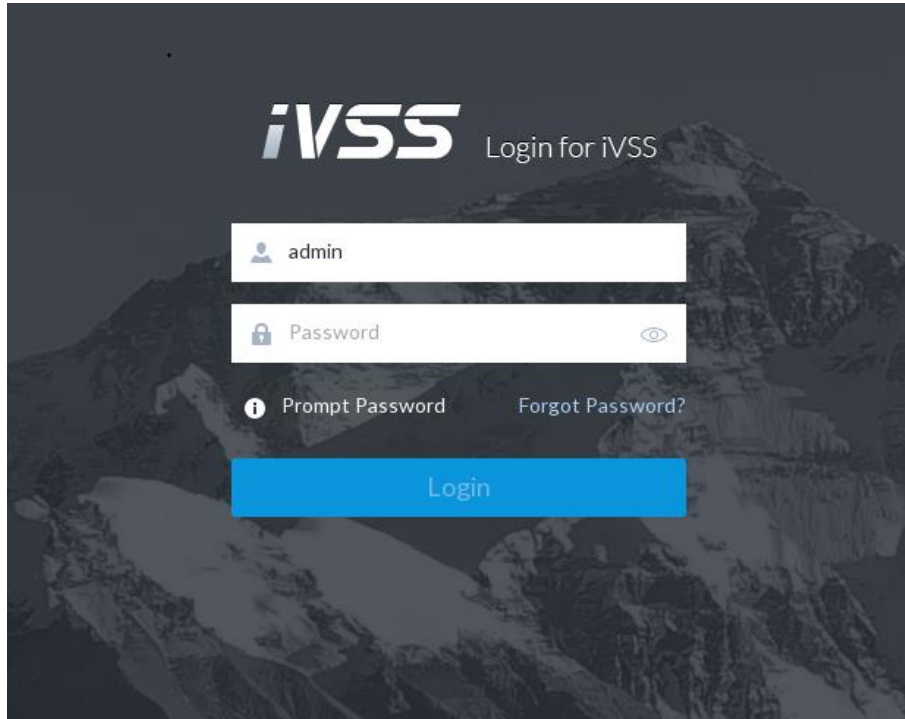
Ensure that the Device is connected with display, mouse and keyboard. For cable connection, see "3.4 Cable Connection."

Operation Steps

Step 1 Turn on the Device.


The login interface is displayed. See Figure 5-16.

Figure 5-16 Login



Step 2 Enter user name and password.



- Click Login. For your device safety, change the admin password regularly and keep it well.
- Move the mouse to  to view the password prompt information. It is to help you remember password.
- In case you forgot password, click Forgot password to reset. See "8.7.3.2 Resetting Password" for detailed information.

Step 3 Click **Login**.

The **LIVE** interface is displayed. See Figure 5-17.




Click  to control the local screen. See "7.4.1 Multiple-screen Control" for detailed information.

Figure 5-17 Live



5.3.3 Logging in to Web Interface

System supports general browser such as Google Chrome, Firefox to access the web to manage the device remotely, operate and maintain the system.



When you are using general browser to access the web, system supports setting function only. It cannot display the view. It is suggested that PCAPP should be used.

Step 1 Open the browser, enter IP address, and then press Enter.

The web login interface is displayed. See Figure 5-18.

Figure 5-18 Web login interface



Step 2 Enter user name and password.



- Click Login. For your device safety, change the admin password regularly and keep it well.
- In case you forgot password, click Forgot password to reset. See "8.7.3.2 Resetting Password" for detailed information.

Step 3 Select the login type among TCP, UDP and Multicast. Keep it TCP if you have no special requirement for TCP or UDP.

Step 4 Click **Login**.



System displays **LIVE** interface.

5.4 Configuring Remote Device

Register remote device to the system. You can view the live video from the remote device, change remote device settings, and so on.

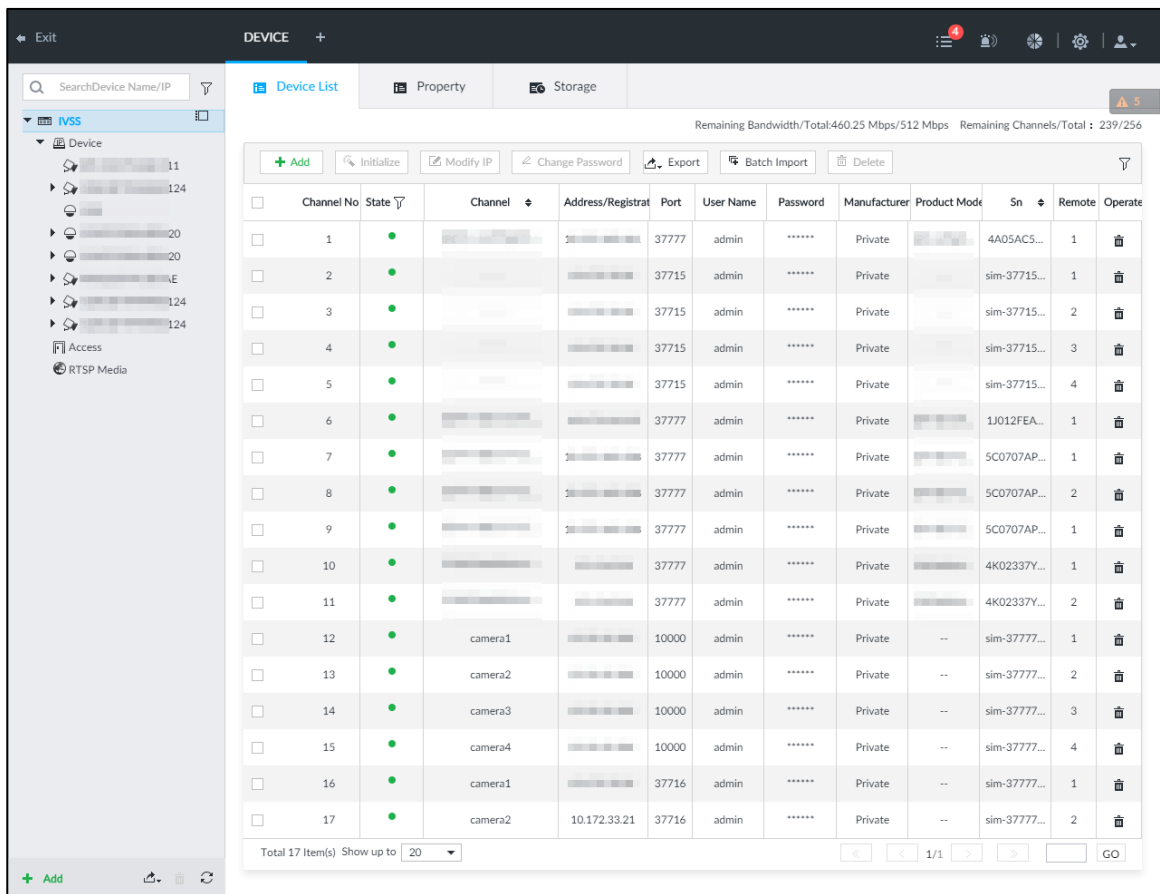
5.4.1 Initializing Remote Device

After you initialize the remote device, you can change remote device login password and IP address. Remote devices can be connected to the Device only after being initialized.

Step 1 Click , or click  on the configuration interface, and then select **DEVICE**.

The **DEVICE** interface is displayed. See Figure 5-19.

Figure 5-19 Device management



Step 2 On the **Device List** interface, click **Add**.

The **Add Device** interface is displayed.

Step 3 On the **Smart Add** interface, click **Smart Search**.

The search results are displayed. See Figure 5-20.




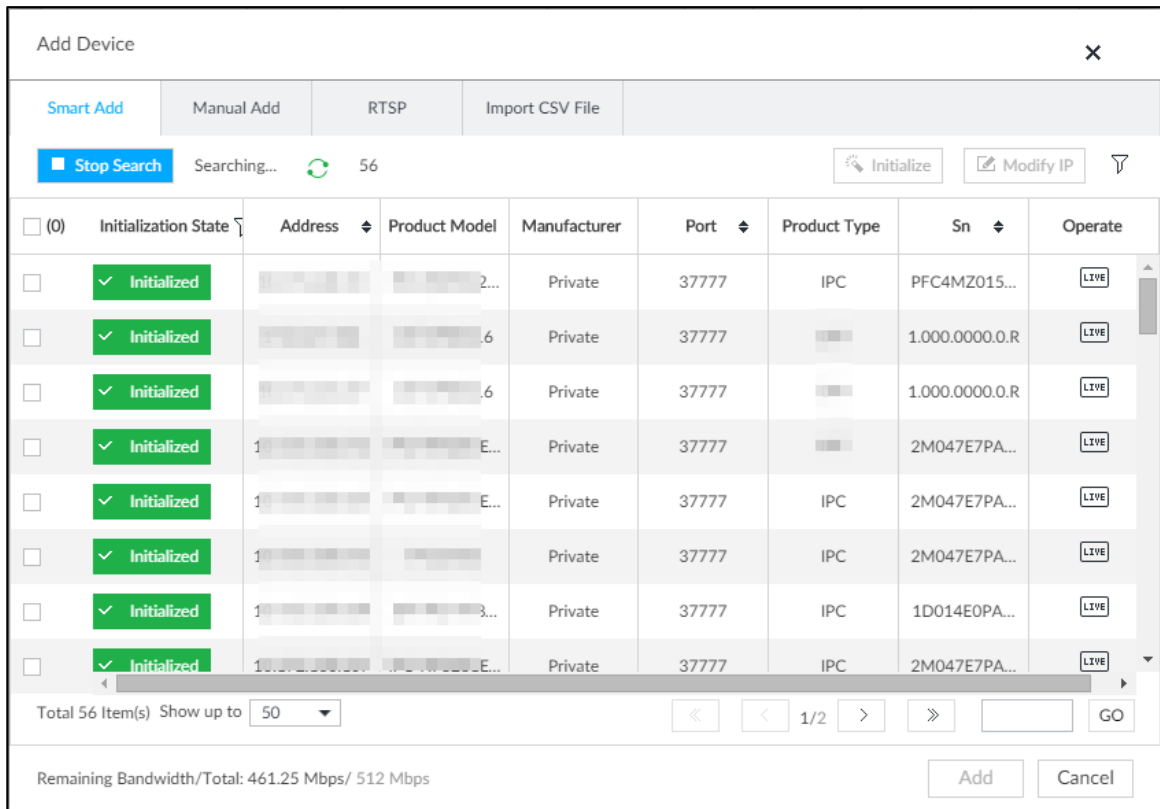
To set search conditions, you can click .

Figure 5-20 Remote device



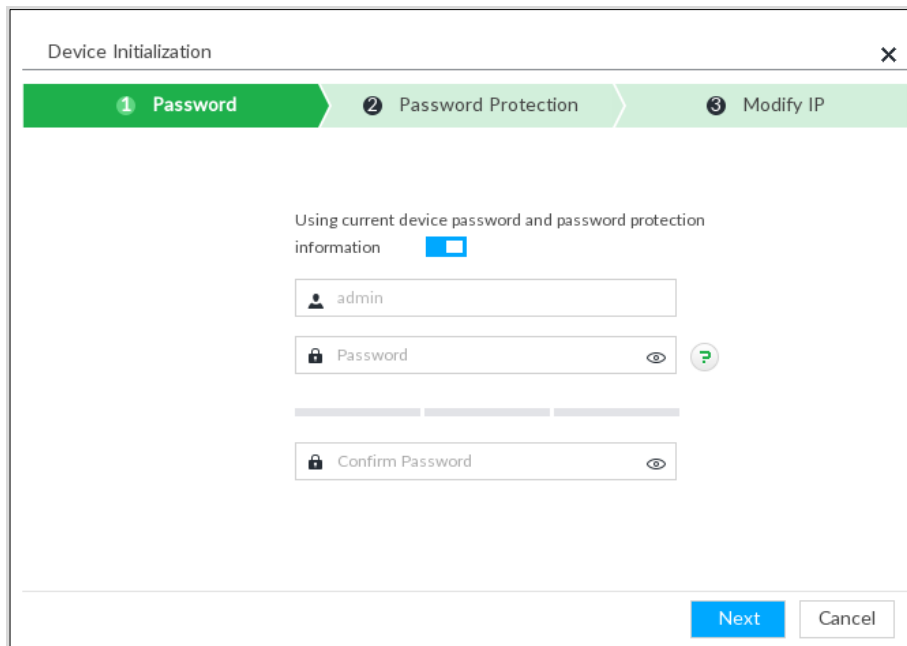
Step 4 Select the uninitialized remote device and then click **Initialize** button.

The **Device Initialization** interface is displayed. See Figure 5-21.

TIPS

Click **Initialization status** and then select **Uninitialized**, you can quickly filter the uninitialized remote device.


Figure 5-21 Initializing the device



Step 5 Set remote device password and password protection.

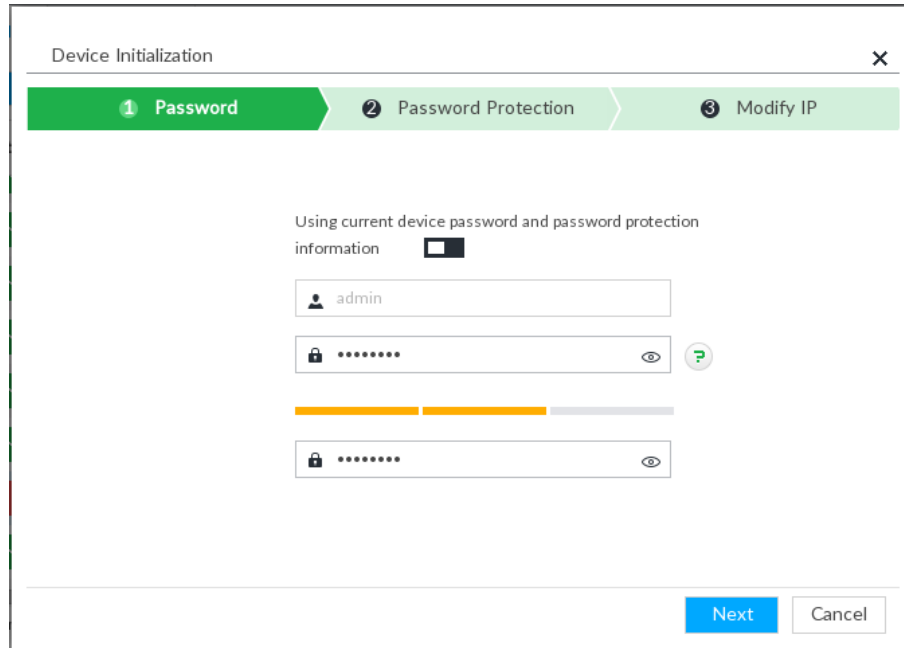


Using current device password and password protection information is enabled by default. Keep it enabled so as to automatically use current device admin password and email without manual configuration. Go to Step 6 if you keep it enabled.

- 1) To manually configure password, click  to disable Using current device password and password protection information.

The password setting interface is displayed. See Figure 5-22.

Figure 5-22 Password setting



- 2) Set parameters. For details, see Table 5-6.

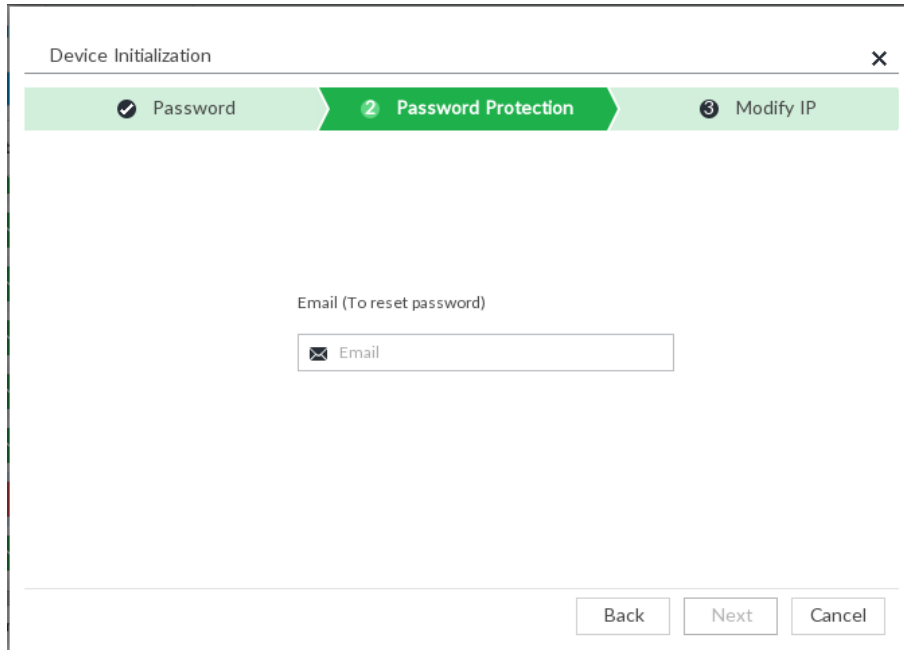
Table 5-6 Description of password parameters

Parameters	Description
Username	The default user name is admin.
Password	In the New Password box, enter the new password and enter it again in the Confirm Password box.
Confirm Password	The new password can be set from 8 characters through 32 characters and contains at least two types from number, letter and special characters (excluding ' " ; : & and space). Enter a strong password according to the password strength indication.

- 3) Click **Next**.

The password setting interface is displayed. See Figure 5-23.

Figure 5-23 Password protection



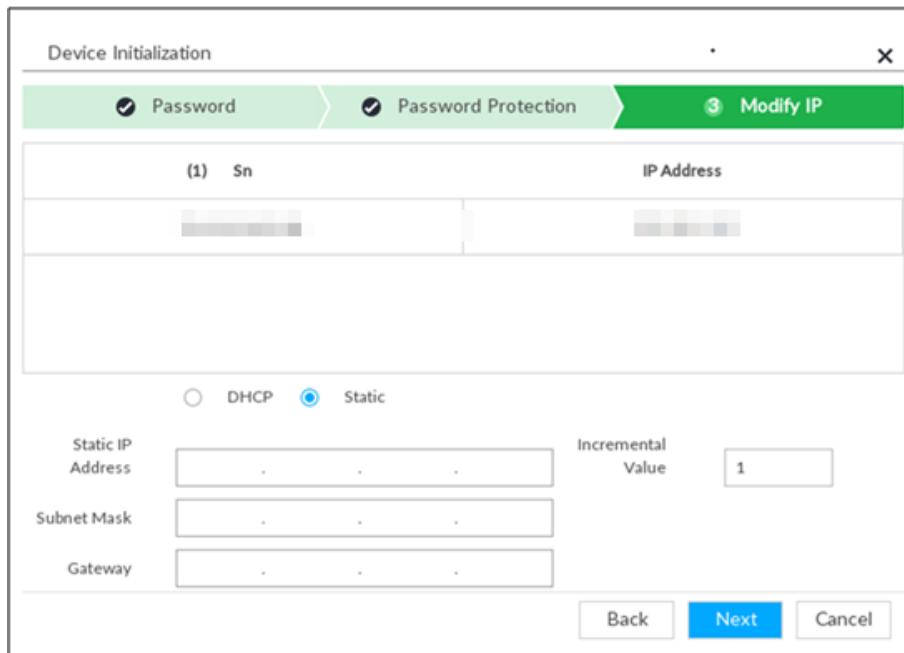
4) Set an email address.

Enter an email address. You can use the email address here to reset password in case you forgot password in the future.

Step 6 Click **Next** button.

The **Modify IP** interface is displayed. See Figure 5-24.

Figure 5-24 Modify IP



Step 7 Set camera IP address.

- When there is DHCP server in the network, select DHCP, and the remote device gets dynamic IP address automatically. It is unnecessary to enter IP address, subnet mask and gateway.
- Select **Static**, and then enter static IP address, subnet mask, default gateway and incremental value.

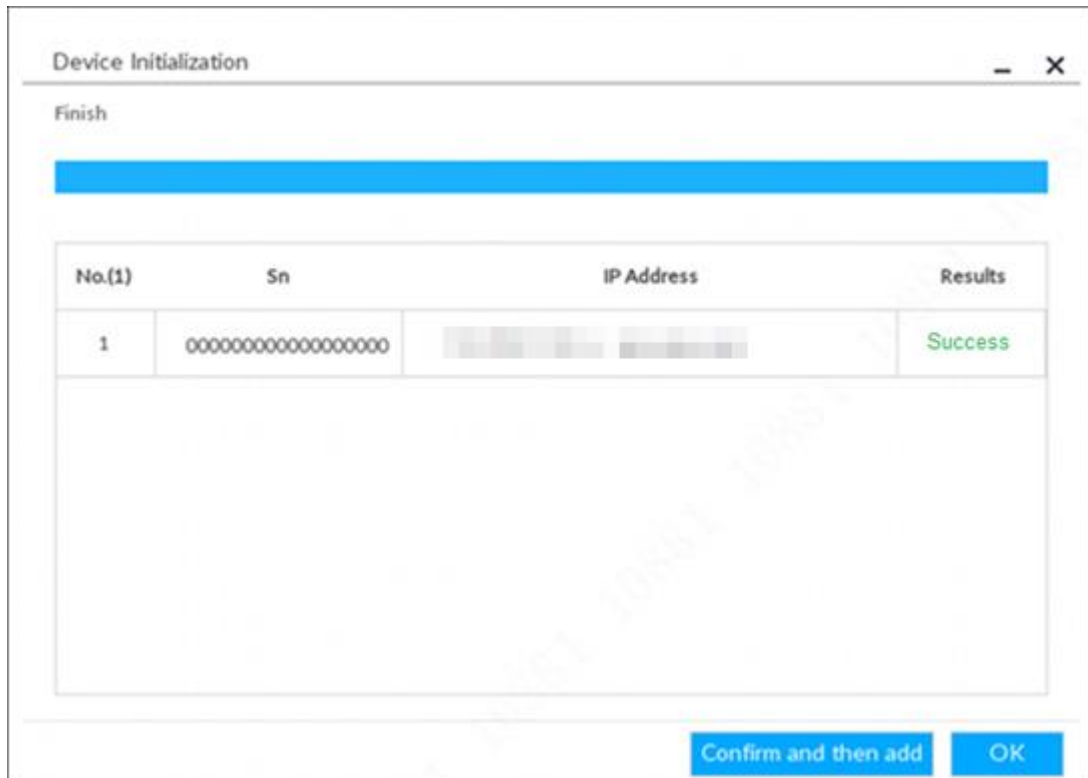


- After you enter incremental value, system can add the fourth address of the IP address one by one to automatically allocate the IP addresses.
- If you want to change several devices IP addresses at the same time, system allocates IP address of the same network segment.
- If there is IP conflict when changing static IP address, device pops up IP conflict dialogue box. If batch change IP address, device automatically skips the conflicted IP and begins the allocation according to the incremental value.

Step 8 Click **Next**.

System begins initializing remote device. See Figure 5-25.

Figure 5-25 Initialize



Step 9 Click **Confirm and Add**, or click **OK**.

- Click **Confirm and Add**: System completes initializing the remote device and then adds the remote device to the list. System goes back to **Add device** interface.
- Click **OK**: System completes initializing remote device. System goes back to **Add device** interface.

5.4.2 Adding Remote Device


Device supports smart add, manual add and template add. For details, see Table 5-7.

Table 5-7 Add mode


Add Mode	Description
Smart Add	Search the remote devices on the same network and then filter to register. For details, see "5.4.2.1 Smart Add." It is useful if you do not know the exact IP address.

Add Mode	Description
Manual Add	Enter the IP address, user name and password of remote device. For details, see "5.4.2.2 Manual Add." For some remote devices, you can enter IP address, user name, and password to register. It is called manual add.
RTSP	Add remote devices through RTSP. For details, see "5.4.2.3 RTSP." To add stream media devices, you are recommended to choose RTSP.
Batch add (by CSV template)	Fill in information about remote device in the template, import the template to add the device. For details, see "5.4.2.4 Batch Add." For batch adding, when IP address, user name and other information of remote device is inconsistent, it is suggested to use this mode.

5.4.2.1 Smart Add

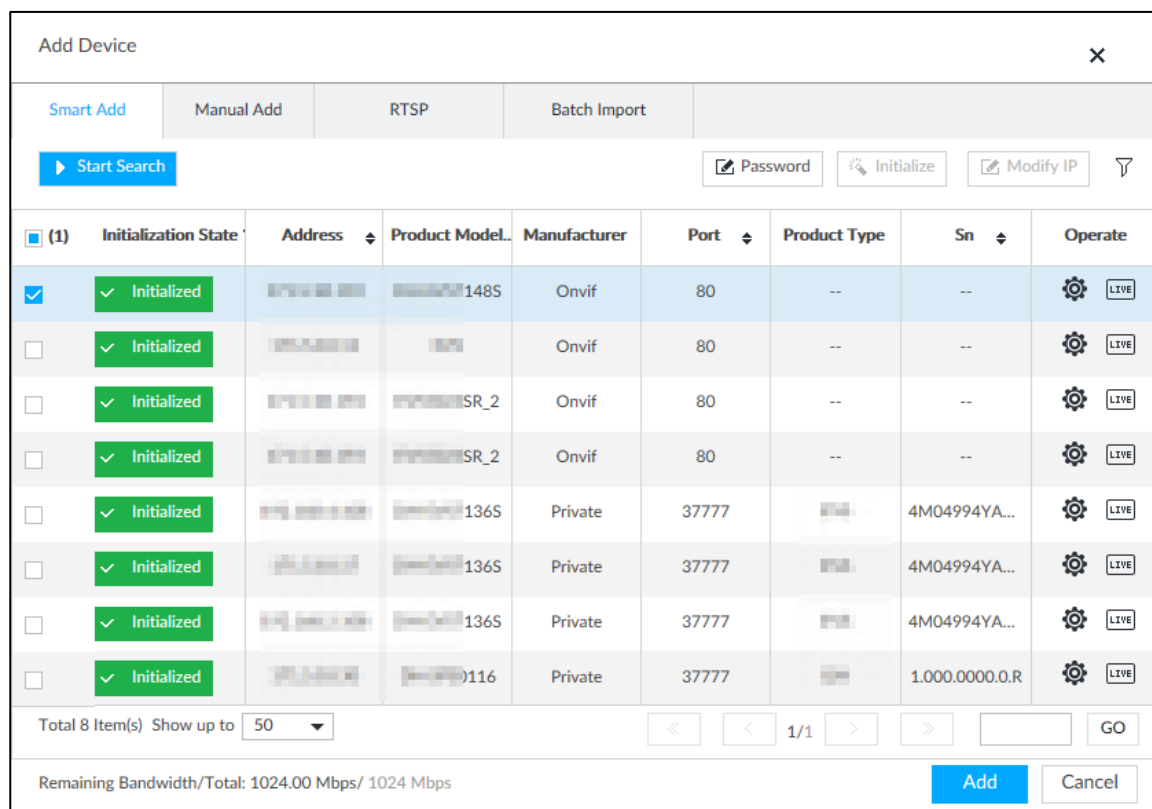
Step 1 Click , and then select **DEVICE**.

The **DEVICE** interface is displayed.

Step 2 Click  or **Add**, and then select **Smart Add**.

The **Smart Add** interface is displayed. See Figure 5-26.

Figure 5-26 Smart add



The screenshot shows the 'Add Device' window with the 'Smart Add' tab selected. A table displays search results for online devices. The table has columns for 'Initialization State', 'Address', 'Product Model', 'Manufacturer', 'Port', 'Product Type', 'Sn', and 'Operate'. The first row is selected, and all devices in the table show a green 'Initialized' status. At the bottom, there are navigation controls and a remaining bandwidth indicator.

(1)	Initialization State	Address	Product Model	Manufacturer	Port	Product Type	Sn	Operate
<input checked="" type="checkbox"/>	✓ Initialized	192.168.1.101	ONVIF148S	Onvif	80	--	--	LIVE
<input type="checkbox"/>	✓ Initialized	192.168.1.102	ONVIF	Onvif	80	--	--	LIVE
<input type="checkbox"/>	✓ Initialized	192.168.1.103	ONVIFSR_2	Onvif	80	--	--	LIVE
<input type="checkbox"/>	✓ Initialized	192.168.1.104	ONVIFSR_2	Onvif	80	--	--	LIVE
<input type="checkbox"/>	✓ Initialized	192.168.1.105	ONVIF136S	Private	37777	ONVIF	4M04994YA...	LIVE
<input type="checkbox"/>	✓ Initialized	192.168.1.106	ONVIF136S	Private	37777	ONVIF	4M04994YA...	LIVE
<input type="checkbox"/>	✓ Initialized	192.168.1.107	ONVIF136S	Private	37777	ONVIF	4M04994YA...	LIVE
<input type="checkbox"/>	✓ Initialized	192.168.1.108	ONVIF116	Private	37777	ONVIF	1.000.0000.0.R	LIVE

Total 8 Item(s) Show up to 50

Remaining Bandwidth/Total: 1024.00 Mbps/ 1024 Mbps

Step 3 Click **Start Search**.

The search results of online devices are displayed. See Figure 5-27. For details, see Table 5-8.



To set search conditions, you can click .

Figure 5-27 Search results

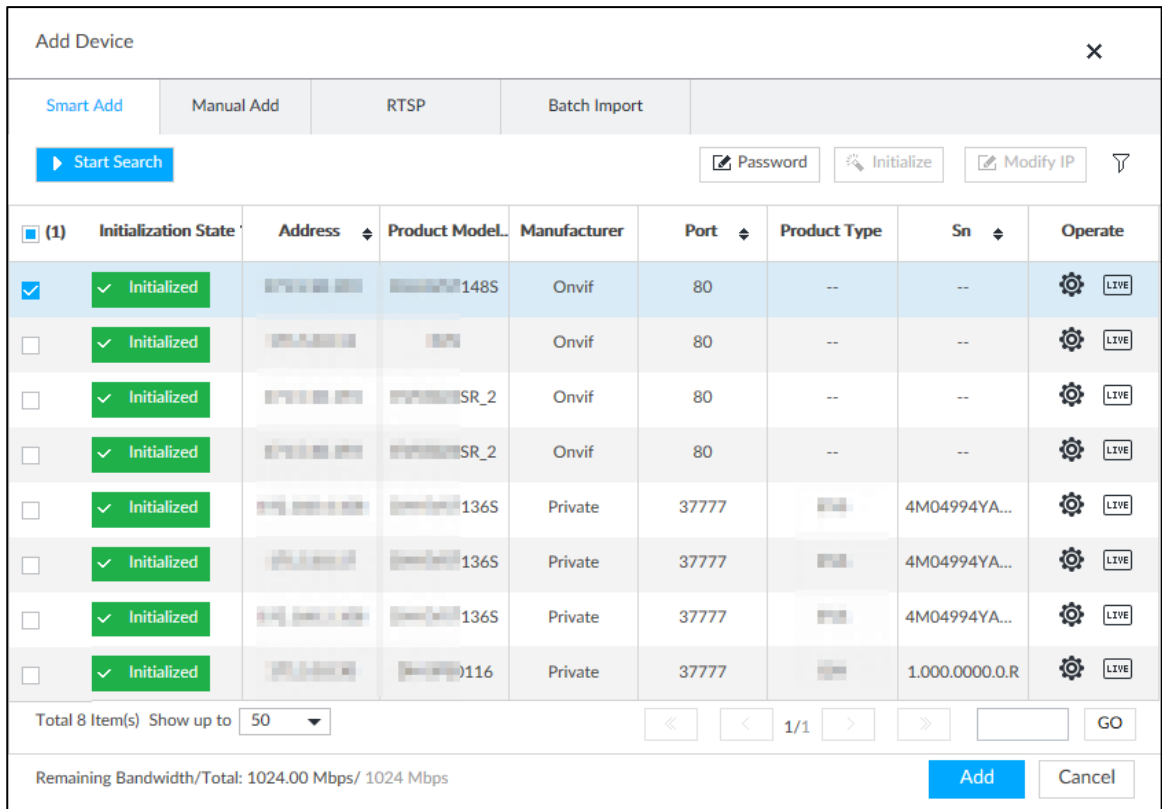


Table 5-8 Result description




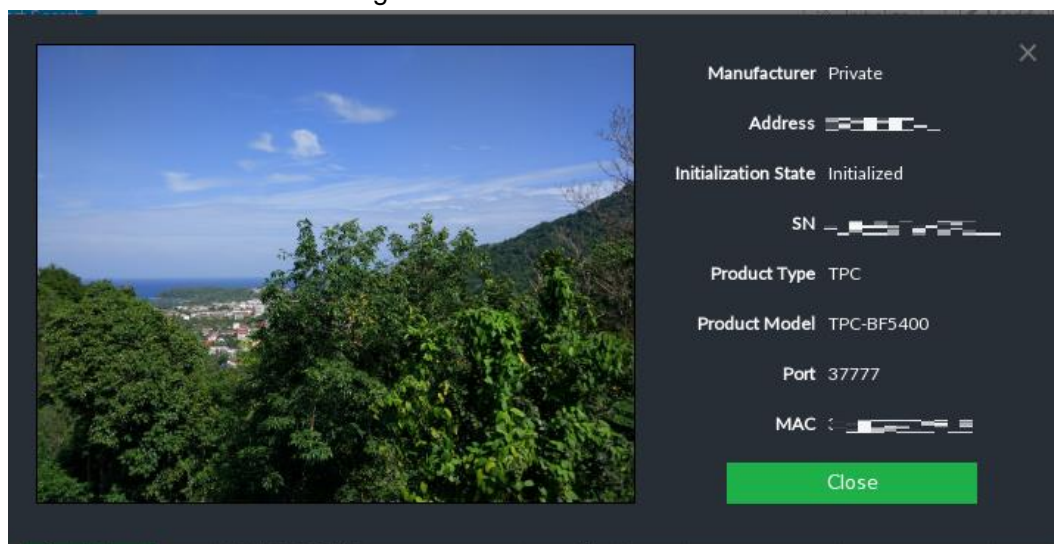
Parameters	Description
Start Search	Click Start Search to Start Searching remote device. Now it becomes Stop Search button. Click Stop Search button to stop searching remote device.
Password	Enter the username and password of the selected device for adding it.
Initialize	Select uninitialized remote device and then click Initialize button to initialize remote device. See "5.4.1 Initializing Remote Device" for detailed information.
Modify IP	See "8.2.2.2 Changing IP Address" to change the registered device IP address.
Initialization State	Displays remote device initialization status. Click ▼ to filter initialized or uninitialized remote device.
Operation	Click  to display real-time video from the remote device. See Figure 5-27. Click  or Close to close the real-time preview window.  You can view the live video if admin password of the remote device is admin, or remote device admin password is the same as the system.
Bandwidth	Displays bandwidth remaining and the total bandwidth.

Figure 5-28 Live view



Step 4 Adding a remote device.

Select a remote device, click **Password**, and then enter the username and password of the selected device. Click **OK**.



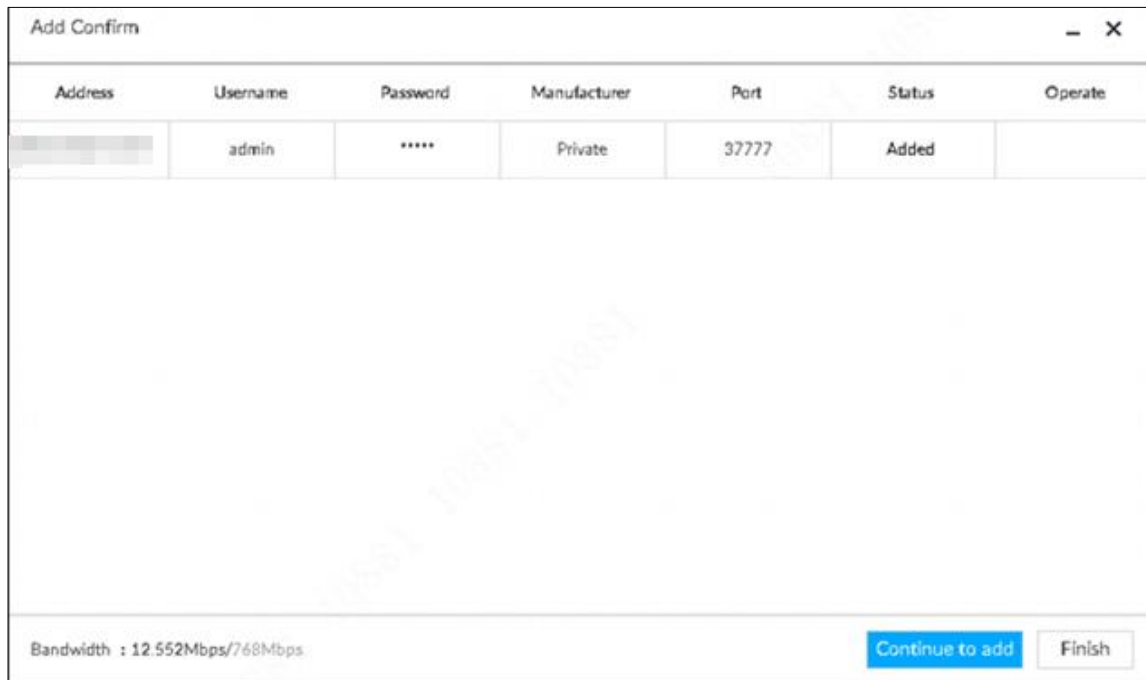
- If you do not enter device username and password, the system will try to add the device by using the username and password of the current EVS.
- During the adding process, click **Cancel** button, you can cancel adding process. Click **Stop** button of the corresponding remote device to cancel add.

Step 5 Click **Add**. The confirmation interface is displayed. See Figure 5-29.



- Double-click remote device IP address, user name, password, manufacturer, port to change corresponding information.
- If system fails to add the remote device, see the reason on the **Status** column to change the remote device information and then click **Retry** to try to add again.
- If a remote device is exception due to network disconnection other reasons, it can also be added. It comes online after the exception is resolved.

Figure 5-29 Confirm



Address	Username	Password	Manufacturer	Port	Status	Operate
	admin	****	Private	37777	Added	


Bandwidth : 12.552Mbps/768Mbps

[Continue to add](#) [Finish](#)


Step 6 Click **Continue to add** or **Finish**.

- Click **Continue to add**, device goes back to **Smart add** interface to add more remote device.
- Click **Finish** to complete adding remote device process. Device displays **Device** interface to view the newly added remote device information.

5.4.2.2 Manual Add

Step 1 Click , and then select **DEVICE**.

The **DEVICE** interface is displayed.

Step 2 Click , and then select **Manual add**.

The **Manual Add** interface is displayed. See Figure 5-30.

Figure 5-30 Manual add

Add Device
✕

Smart Add

Manual Add

RTSP

Import CSV File

+ Add Device

🗑 Delete

There are no rows in the table!

Add Offline

Add

Cancel

Step 3 Click **Add Device**.

The **Add Device** interface is displayed. See Figure 5-31.

Figure 5-31 Add device

Add Device
✕

Smart Add

Manual Add

RTSP

Import CSV File

+ Add Device

🗑 Delete

☑ (1)	Manufacturer	Address/Registra	User Name	Password	Port	Channel No	Remote CH No.	Operate
☑	Private		admin	*****	37777	Auto Allocation		⚙ 🗑 +

Total 1 Item(s) Show up to

<<
<
1/1
>
>>

GO

Add Offline

Add

Cancel

Step 4 Set parameters. For details, see Table 5-9.

Table 5-9 Parameters





Parameters	Description
Manufacturer	<p>Displays the connection protocol of the remote device. Default protocol of the system is Private. Double-click Private to select other protocols.</p> <p>To add stream media device, select Rtp protocol, and enter RTSP address of stream media device in Address column. See Figure 5-32.</p> <p>Rtsp://<user name>:<password>@<IP address>:<port>/cam/realmonitor?channel=1&subtype=0U.</p> <ul style="list-style-type: none"> ● Port: Enter port number. The default setting is 554. ● Channel: Enter channel number of the stream media device to be added. ● Subtype: Set record bit stream type. It includes main stream 0 and sub stream 1. <p>For example rtsp://admin:admin@192.168.20.25:554/cam/realmonitor?channel=1&subtype=0.</p>  <p>To add a stream media device, it is unnecessary to set user name, password, and port.</p>
Address/Registration ID	Double-click the empty cell in the Address/Registration IP column to enter the IP address or RTSP address of remote device.
Username	Double-click the empty cells in the User Name and Password columns to enter the username and password of remote device.
Password	
Port	Displays the default port number of remote device. If the port number has been modified, double-click the port cell to enter the current port number of the remote device.
Channel No.	Double-click this column to select the channel number of the device in IVSS. If you select Auto Allocation , IVSS will provide a channel number automatically.
Remote CH No.	<p>Select the channel number of a remote device.</p> <ol style="list-style-type: none"> 1. Click  in the Operate column, the Setting interface is displayed. See Figure 5-32. 2. Select a link type. 3. Enter the total number of channels. Click Selected, and then the corresponding channel is displayed. 4. Click OK.
Others	<p>Delete current line or add a new line.</p> <ul style="list-style-type: none"> ● Click  to delete current line information. Select multiple lines of remote device information, and then click Delete to batch delete the selected information. ● Click  to add a new line. Enter remote device information to add several devices at the same time.

Figure 5-32 Setting

Setting

Link Type Self-Adaptive TCP UDP Multicast

Total Channels

Select - Selected Clear

Channel 1-1
1

OK Cancel

Step 5 Select the remote device and then click **Add**. Device begins adding remote device and pops up the confirmation interface. See Figure 5-33.



- During the adding process, click **Cancel** button, you can cancel adding process. Click **Stop** button of the corresponding remote device to cancel.
- Double-click remote device IP address, user name, password, manufacturer, port to change corresponding information.
- If system fails to add the remote device, see the reason on the **Status** column to change the remote device information and then click **Retry** to try to add again. See Figure 5-33.
- If a remote device is exception due to network disconnection other reasons, it can also be added. It comes online after the exception is resolved.

Figure 5-33 Confirm

Address	Username	Password	Manufacturer	Port	Status	Operate
[blurred]	admin	****	Private	37777	Added	


Bandwidth : 12.552Mbps/768Mbps

[Continue to add](#) [Finish](#)

Step 6 Click **Continue to add** or **Finish**.

- Click **Continue to add**, device goes back to **Smart add** interface to add more remote device.
- Click **Finish** to complete adding remote device process. Device displays **Device** interface to view the newly added remote device information.

5.4.2.3 RTSP

Step 1 Click , and then select **DEVICE**.

The **DEVICE** interface is displayed.

Step 2 In the **Device List** interface, click **Add**.

The **Add Device** interface is displayed.

Step 3 Click **RTSP**.

The **RTSP** interface is displayed. See Figure 5-34.

Figure 5-34 RTSP

The screenshot shows a dialog box titled "Add Device" with a close button (X) in the top right corner. Below the title bar are four tabs: "Smart Add", "Manual Add", "RTSP" (which is highlighted in blue), and "Import CSV File". The "RTSP" tab contains three input fields: "sto.MainStream" with the text "Rtsp://", "Extra Stream" with the text "Rtsp://", and "Channel No" which is a dropdown menu. At the bottom of the dialog, there is a status bar that reads "Remaining Bandwidth/Total: 459.02 Mbps/ 512 Mbps" and two buttons: "Add" and "Cancel".

Step 4 Enter RTSP address as required.


RTSP address format is `rtsp://<username>:<password>@<IP address>:<port>/cam/realmonitor?channel=1&subtype=0`.

- Port: 554 by default.
- Channel: The channel number of the stream media device to be added.
- Subtype: Stream type. 0 for main stream, and 1 for sub stream.


Step 5 Select a channel No.

Step 6 Click **Add**.

5.4.2.4 Batch Add

Step 1 Click , and then select **DEVICE**.

The **DEVICE** interface is displayed.

Step 2 Click , and then select **Import CSV file** tab.

The **Import CSV file** interface is displayed. See Figure 5-35.


Figure 5-35 Import CSV file

The screenshot shows a web interface titled "Add Device" with a close button (X) in the top right. Below the title bar are four tabs: "Smart Add", "Manual Add", "RTSP", and "Import CSV File" (which is selected). Under the "Import CSV File" tab, there is a "Choose File" text input field followed by "Browse", "Import", and "Download Template" buttons. Below this is a table with the following columns: a checkbox, "(0)", "Manufacturer", "Address", "User Name", "Password", "Port", "Channel No", "Remote CH No.", and "Operate". The table is currently empty. At the bottom left, it says "Total 0 Item(s) Show up to 50" with a dropdown arrow. At the bottom right, there are navigation buttons: "<<", "<", "1/1", ">", ">>", a search input field, and a "GO" button. At the very bottom, there is an "Add Offline" button on the left and "Add" and "Cancel" buttons on the right.

Step 3 Fill in template file.

- 1) Click **Download Template** to download template file.

File path might vary depending on interface operations, and the actual interface shall prevail.

- At PCAPP, click , select Download content to view file saving path. For details, see 11.3 Viewing Downloads
- Select file saving path during local operation.



Connect USB device to the system if you are on the local menu to operate.

- During web operations, files are saved under default downloading path of the browser.

- 2) Fill in template file and save according to your actual situation.

The following information of template file shall be filled in. See Figure 5-36.



If information about remote device is not filled in completely, improve it after importing template.

Figure 5-36 File


	A	B	C	D	E	F	G
1	IP Address	Port	Channel No.	Channel Name	Manufacturer	User Name	Password
2							
3							

Step 4 Import template file.

- 1) Click **Browse** to select the upgrade file.
- 2) Click **Import**.

The imported information about remote device is displayed.



- When information about remote device is incomplete, complement it according to your actual situation.
- Click  to delete current line information.

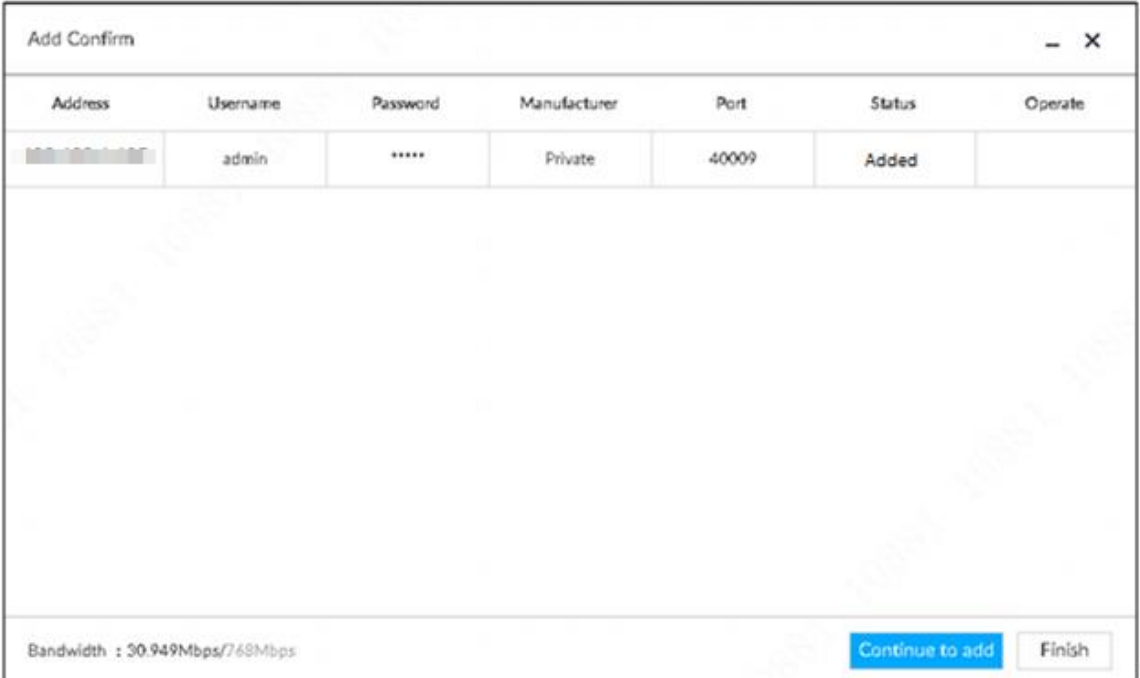
Step 5 Add remote devices.

Select the remote device and then click **Add**. Device begins adding remote device and pops up confirmation interface. See Figure 5-37.



- During the adding process, click **Cancel** button, you can cancel adding process. Click **Stop** button of the corresponding remote device to cancel add.
- Double-click remote device IP address, user name, password, manufacturer, port to change corresponding information.
- If system fails to add the remote device, see the reason on the **Status** column to change the remote device information and then click **Retry** to try to add again.

Figure 5-37 Confirm



Address	Username	Password	Manufacturer	Port	Status	Operate
[redacted]	admin	****	Private	40009	Added	

Bandwidth : 30.949Mbps/7.68Mbps

[Continue to add](#) [Finish](#)

Step 6 Click **Continue to add** or **Finish**.

- Click **Continue to add**, device goes back to **Smart add** interface to add more remote device.
- Click **Finish** to complete adding remote device process. Device displays **Device manager** interface to view the newly added remote device information.

Step 7 (Optional) You can add offline devices when the network is exception. When the network recovers, the added offline device will automatically come online.

Click next to offline device to add an offline device.

Step 8 (Optional) click next to **Overwrite** to enable the function. This function is used when the IP address of a new device is the same as that of a previously added device, the configuration of the new device will overwrite the old one.

6 AI Operations

In addition to the basic video monitoring functions, the Device can also provide a number of AI functions including face recognition, people counting, video metadata, ANPR, and IVS (behavior detections such as fence-crossing, intrusion, loitering, crowd gathering, parking and more. See "6.6 IVS").

This chapter introduces how to configure the AI functions respectively.

The AI detections can be done by camera (AI by camera) or by IVSS (AI by device).

- AI by camera: When configuring an intelligent detection, if you select AI by camera, the intelligent analysis job is completed on the camera, and IVSS just receives and processes the results.
- AI by device: When configuring an intelligent detection, if you select AI by device, the camera uploads video and snapshots, and then IVSS is responsible for the video analysis job.



- The AI functions might vary depending on the device function capability. The actual interface shall prevail.
- When AI by camera is enabled, complete AI detection configuration at remote device. See remote device user's manual.
- The **AI by Camera** tab does not appear if the current camera does not support this function. The actual interface shall prevail.
- Some AI features are conflicting. Do not enable conflicting AI features at the same time.

6.1 Overview

View the usage status of the AI functions of all remote devices.


Click  at the upper-right corner of the homepage to open the **Event** interface. The **Overview** interface is displayed by default, which shows the usage status of the AI functions of all remote devices. See Figure 6-1.

Figure 6-1 Overview

Channel No.	State	Channel	Address/Registration ID	Face	Video Metadata	Ivs	Vehicle	Video Detect
1	●	IPC		■	■	■	■	■
2	●	camera1		■	■	■	■	■
3	●	camera2		■	■	■	■	■
4	●	camera3		■	■	■	■	■
5	●	camera4		■	■	■	■	■
6	●	108		■	■	■	■	■
7	●	IPC		■	■	■	■	■
8	●	IP PTZ Camera		■	■	■	■	■
9	●	IPC		■	■	■	■	■
10	●	IPC		■	■	■	■	■
11	●	IPC2		■	■	■	■	■
12	●	camera1		■	■	■	■	■
13	●	camera2		■	■	■	■	■
14	●	camera3		■	■	■	■	■
15	●	camera4		■	■	■	■	■
16	●	camera1		■	■	■	■	■
17	●	camera2	10.172.33.21	■	■	■	■	■



■ indicates that the AI function is enabled. ■ indicates that AI by device is enabled.

6.2 Face Detection

System triggers alarms when human faces are detected within the detection zone.

6.2.1 Enabling AI Plan

To use AI by camera, you need to enable AI plan first.



- AI plan is available on select models.
- The Device automatically shows the AI functions available on the connected cameras.

Step 1 Click , or click  on the configuration interface, and then select **EVENT**.

The **EVENT** interface is displayed.

Step 2 Select a camera in the device tree on the left.

Step 3 Select **AI Plan > AI Plan > AI Plan**.

The **AI Plan** interface is displayed. See Figure 6-2.



- The interface might vary depending on the function capabilities of cameras. The actual interface shall prevail.
- When the camera is a PTZ camera, configure presets on the camera system first, and then you can set AI features for each preset of the PTZ camera. See Figure 6-3.

Figure 6-2 AI plan (1)

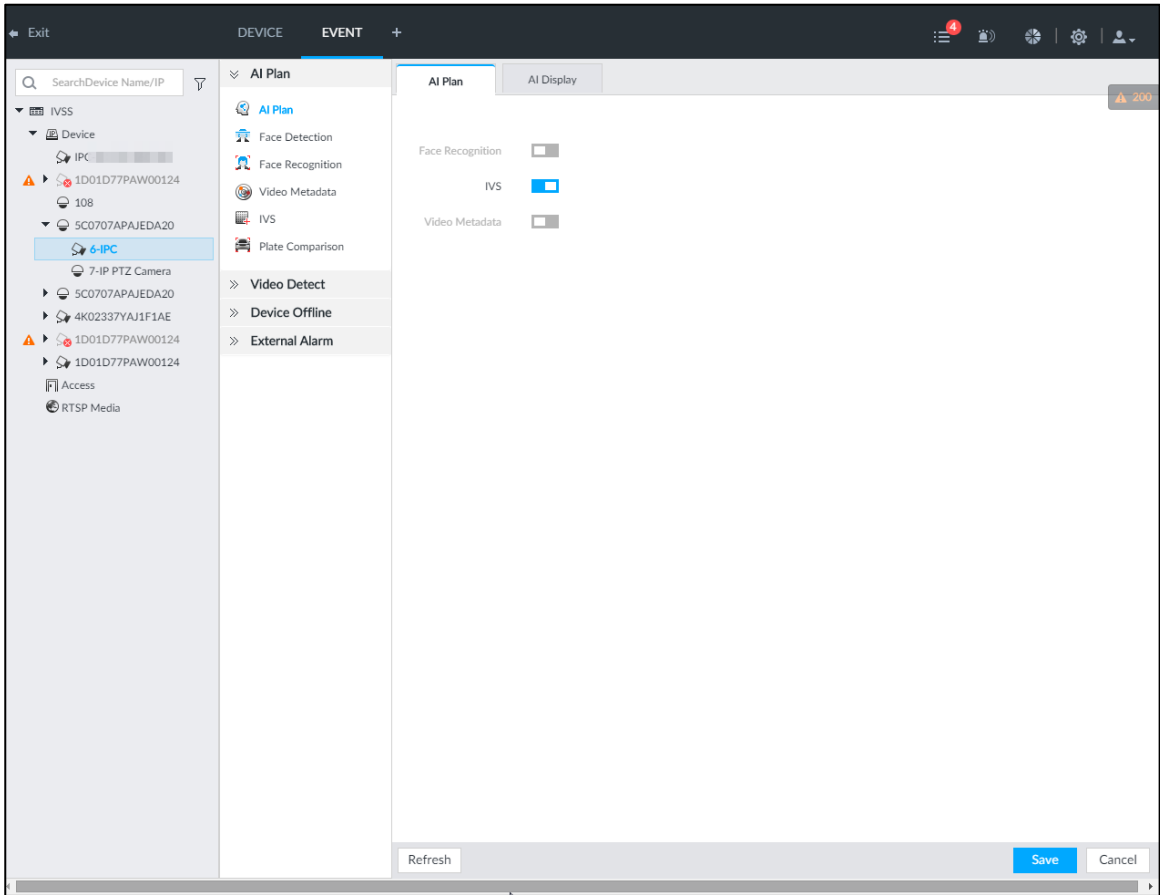
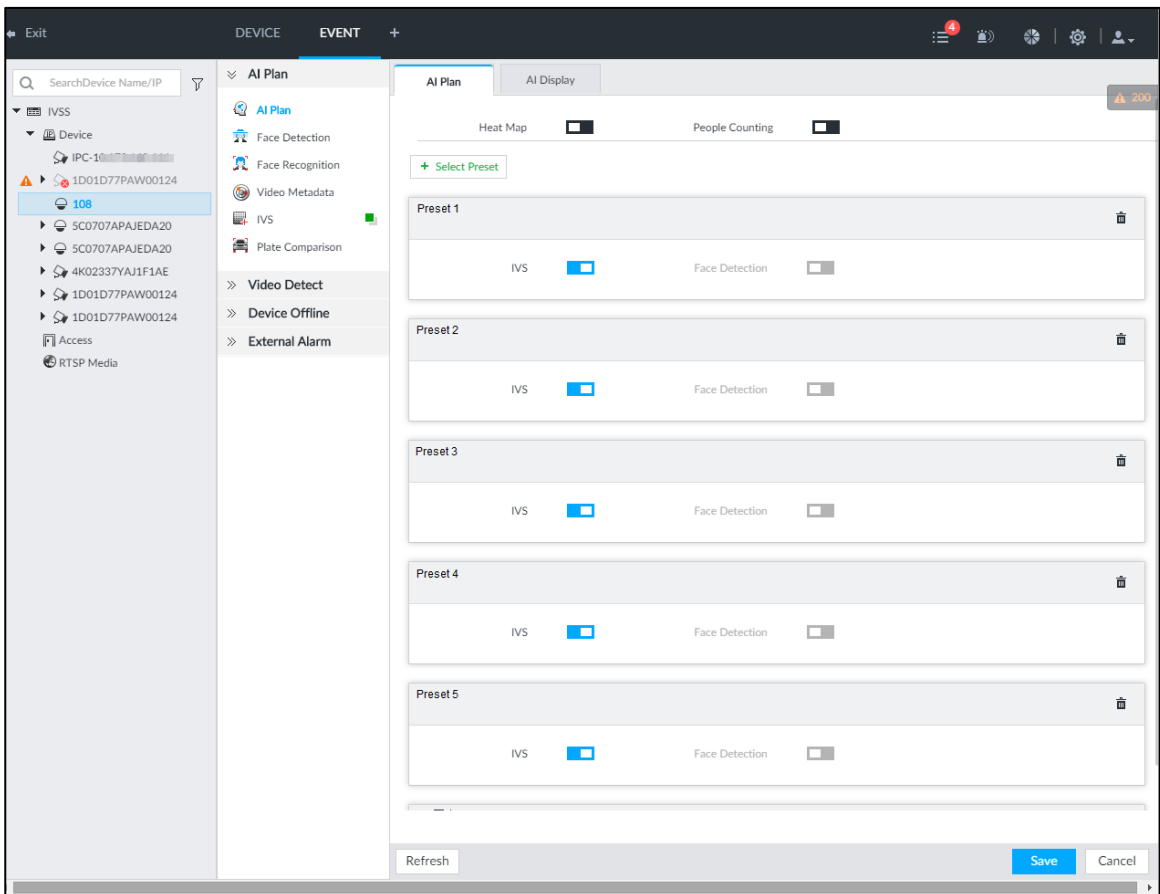


Figure 6-3 AI plan (2)





Step 4 Click to enable AI detection plan. The icon becomes .

When there is a conflict between the to-be-enabled AI plan and an enabled plan, disable the enabled plan first.

Step 5 Click **Save**.

6.2.2 Configuring Face Detection

Configure alarm rule of face detection.

Step 1 Click  or click  on the configuration interface, and then select **EVENT**.

The **EVENT** interface is displayed.

Step 2 Select a remote device in the device tree on the left.

Step 3 Select **AI Plan > Face Detection**.

The **Face Detection** interface is displayed. See Figure 6-4 or Figure 6-5.

Figure 6-4 AI by camera

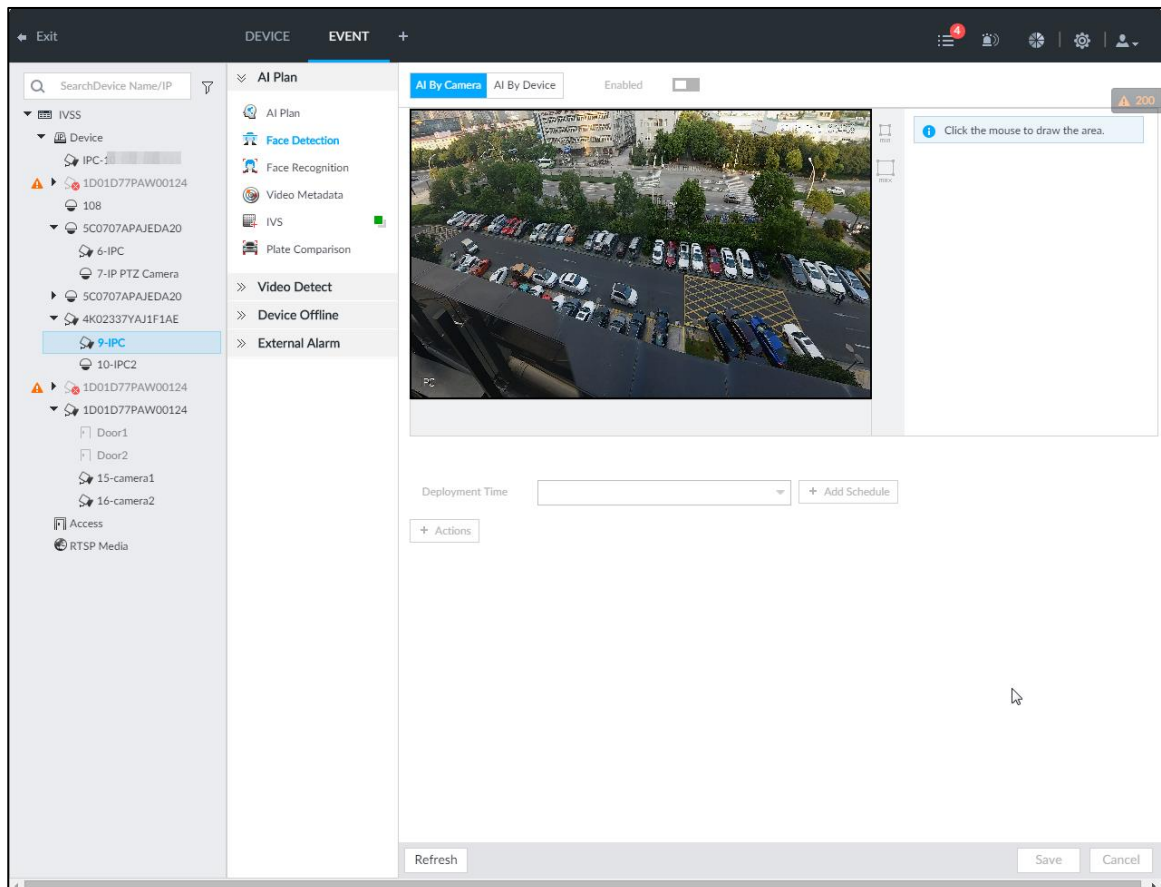
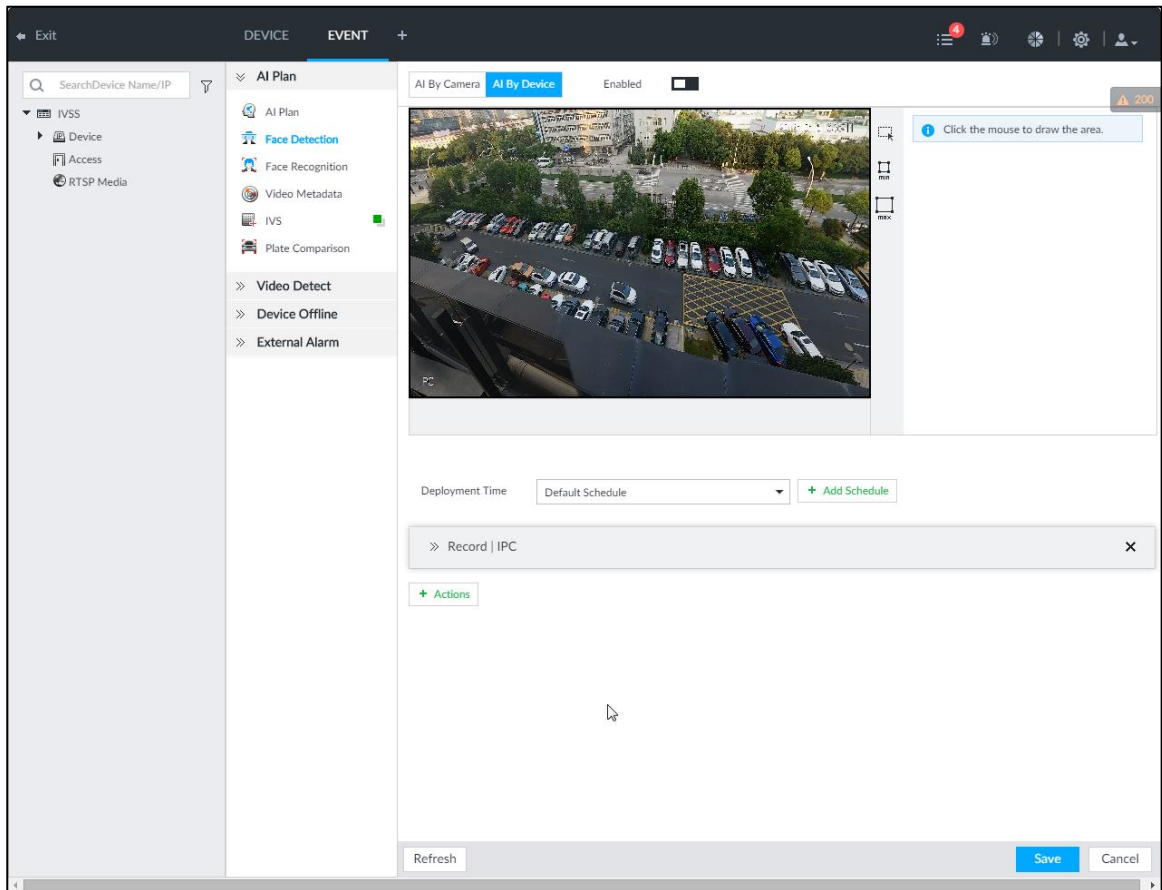



Figure 6-5 AI by device



Step 4 Click **AI by camera** or **AI by device**, and then click  to enable face detection.





AI by camera supports **Face Roi** function. After enabling **Face Roi** function, system displays enhanced human face zone on the surveillance window.

Step 5 Set detection region on the video (yellow area). See Figure 6-6.

Figure 6-6 Area



- Click  or white dot on detect region frame, and drag to adjust its range.

- Click  or  to set the minimum size or maximum size of the face detection area. System triggers an alarm once the size of detected target is between the maximum size and the minimum size.

Step 6 Click **Deployment Time** to select schedule from the drop-down list.

After setting arm period, system triggers corresponding operations when there is a motion detection alarm in the specified period.



You can select an existing schedule from the **Deployment Time** drop-down list. You can also add a new schedule. For details, see "8.8.4 Schedule."

Step 7 Click **Action** to set alarm action. See "8.4.1 Alarm Actions" for detailed information.

Step 8 Click **Save**.

6.2.3 Live View of Face Detection


You can view real-time face detection images and video.

6.2.3.1 Setting AI Display

You can configure display rule of face detection results.



Before using this function, ensure that view has been created. See "7.1.1 View Management" for detailed information.

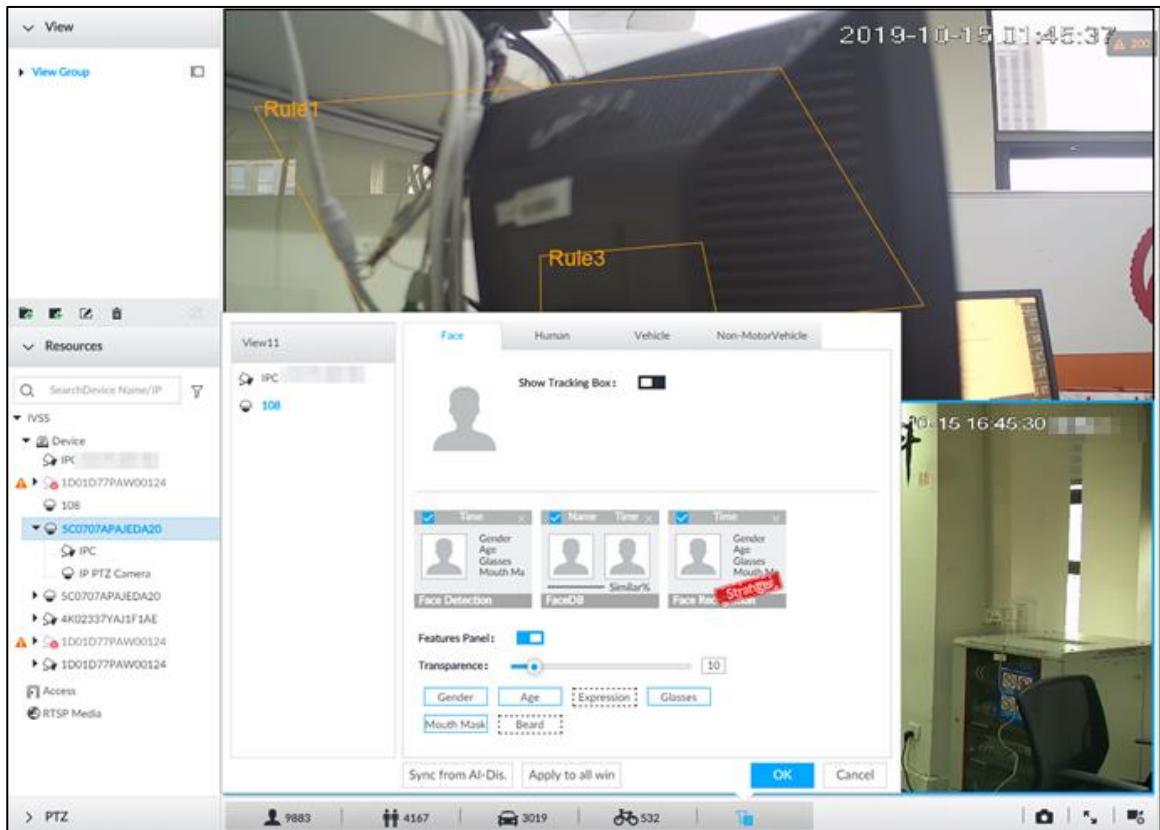
Step 1 On the **LIVE** interface, click  and select the **Face** tab.

The **Face** interface is displayed. See Figure 6-7.



- Click **Sync from AI-Dis.**, obtain global smart detection display rule of IVSS. See "8.4.2.3.2 Setting AI Display" for detailed information.
- Click **Apply to all windows** to copy current configuration to other window(s).

Figure 6-7 Face



Step 2 Enable **Show Tracking Box** by clicking .

After it is enabled, when the system detects face or human, the window will display corresponding rule box.

Step 3 Enable **Features Panel**, and select feature(s) you want to display.

- 1) Click next to **Features Panel**, to enable the function. When the panel is enabled, the snapshots of detected faces are displayed on the live view.
- 2) Click to select **Face Detection** tab. indicates that the panel is selected.
- 3) (Optional) Drag to adjust features panel transparency. The higher the value, the more transparent the features panel.
- 4) (Optional) Select the features you need to display.
 - System supports displaying 4 feature types.
 - System has checked four features by default. To select other features, cancel the selected features, and then select the ones you need.

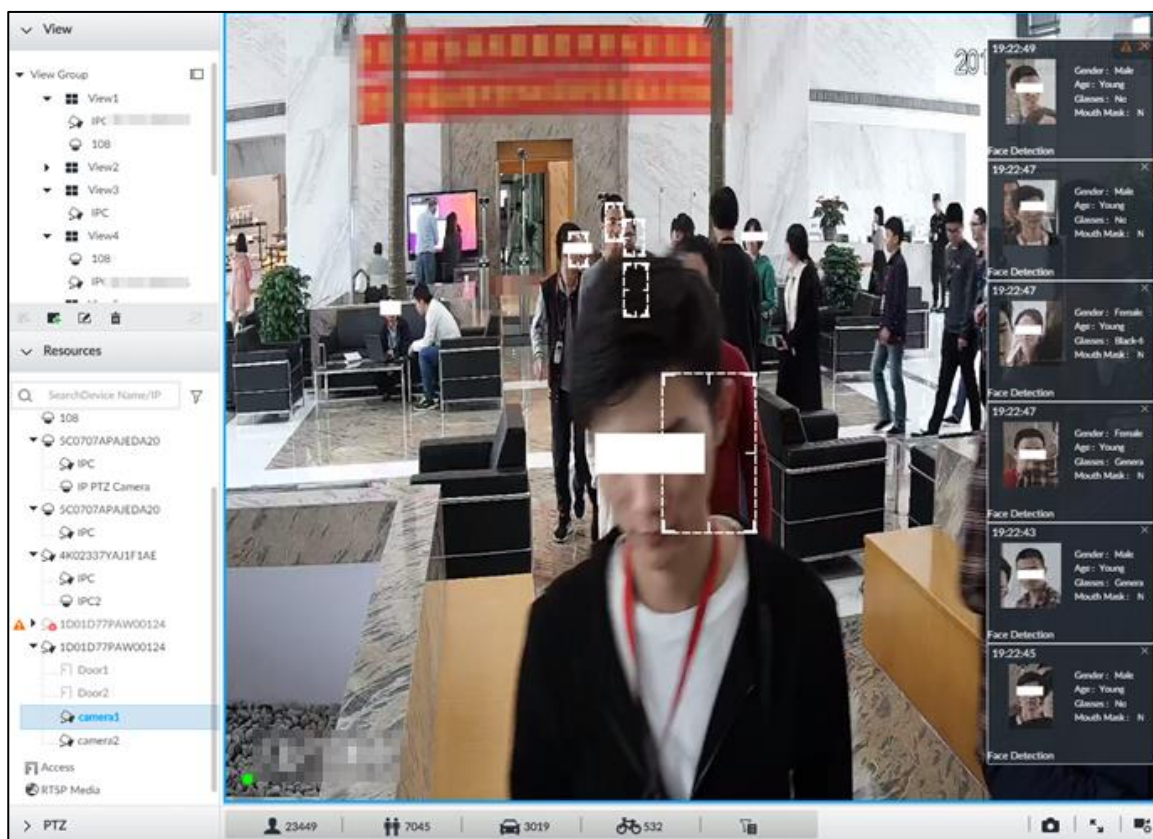
Step 4 Click **OK** to save the configuration.

6.2.3.2 Live View

Go to the **LIVE** interface, enable view, and then view videos are displayed. See Figure 6-8.

- The view window displays currently detected face rule boxes.
- Features panels are displayed on the right side in real time. The features panel displays detection time, face snapshot and face features details.




Figure 6-8 Live



Move the mouse pointer to a features panel, and the operation icons are displayed. See Figure 6-9.

Figure 6-9 Face database



- Click  to add this image to the face database. See "6.3.3.2.3 Adding from Detection Snapshots" for detailed information.
- Click  or double-click the detected image, so the system starts to play back the recorded videos (about 10 s) at the time of snapshot.
- Click  to open the **Search by Face** interface where you can use this face image to search all history face records for the appearance records of the current face.

6.2.3.3 Face Records



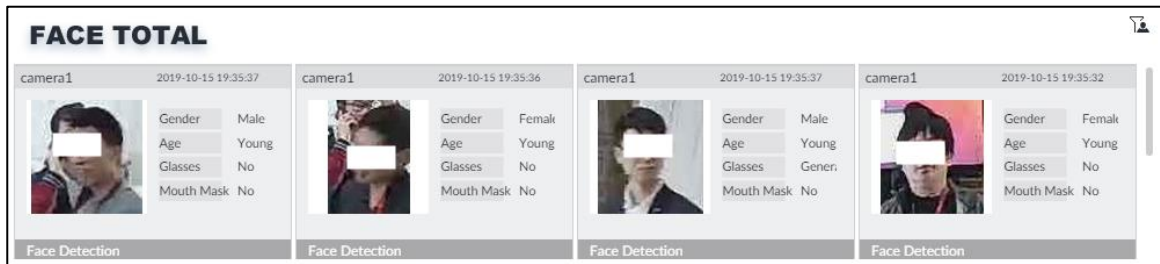




On the **LIVE** interface, click . The **FACE TOTAL** interface is displayed. Click , and then select **Face Detection**. The latest face detection records are displayed. See Figure 6-10.

Figure 6-10 Detection image



In the **FACE TOTAL** interface, the following operations are available.

- Point to a piece of face record, click , and then you can quickly add this image to the face database. See "6.3.3.2.3 Adding from Detection Snapshots" for detailed information.
- Point to a piece of face record, click  or double-click the detected image, and then the system starts to play back the recorded videos (about 10 s) at the time of snapshot.
- Point to a piece of face record, click , and then you can save that record locally including the video and pictures.
- Point to a piece of face record, click , and then the system automatically searches videos and face pictures of all channels for the similar face in the defined period.

6.2.4 Face Search

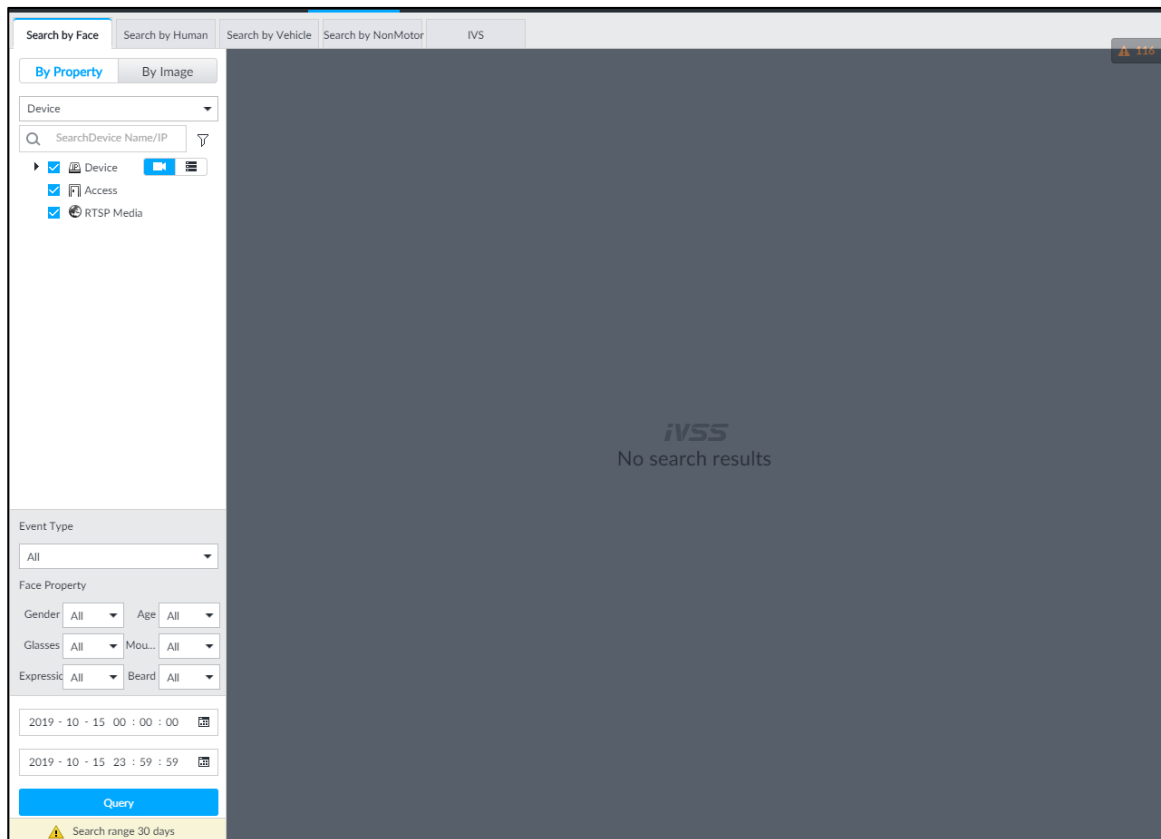
Search for face detection information, including face detection image, record and features.

6.2.4.1 Searching by Property

Step 1 On the **LIVE** interface, click , select AI SEARCH > Search by Face > By Property.

The **By Property** interface is displayed. See Figure 6-11.

Figure 6-11 Search by property



Step 2 Select a remote device, and then set **Event Type** to be **Face Detection**.



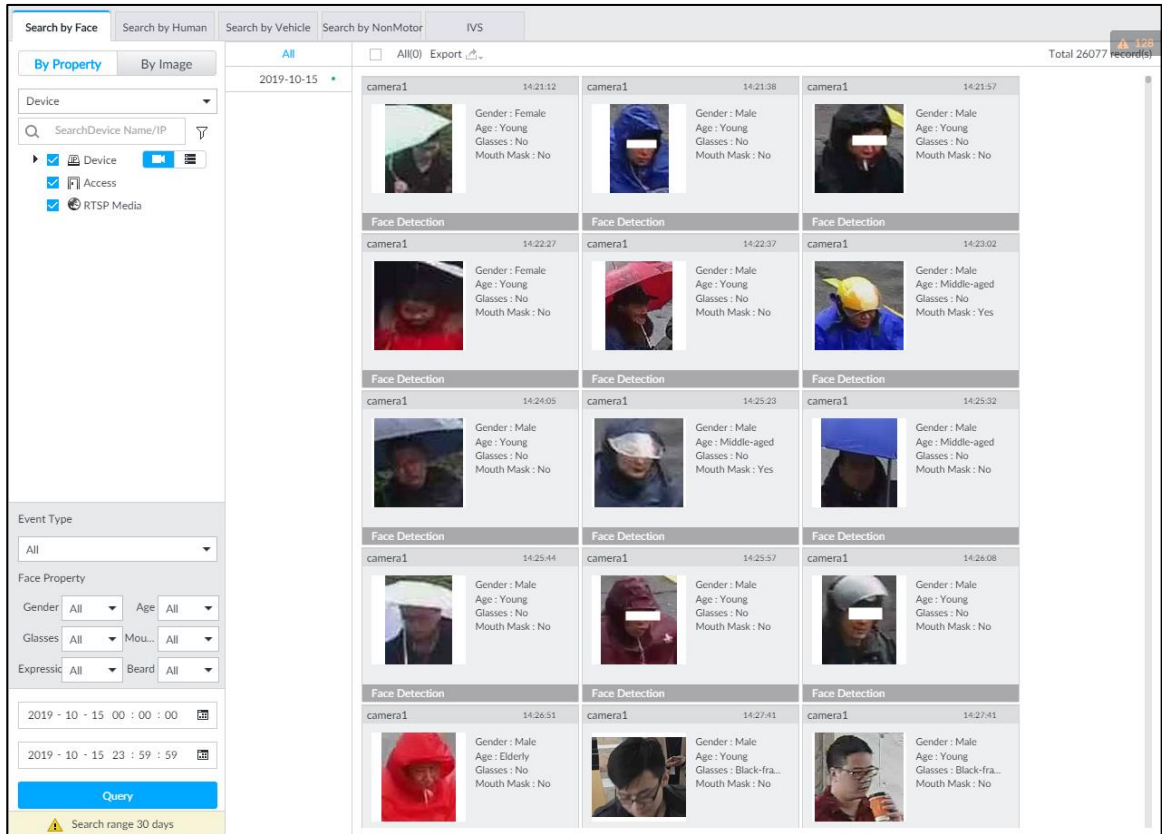
In the **Event Type** drop-down list, if you select **All**, the search results will include both face detection records and face recognition records.

Step 3 Set face property and time.

Step 4 Click **Query**.

The search results are displayed. See Figure 6-12.

Figure 6-12 Search results



Point to a piece of record, the following icons are displayed. See Figure 6-13. For details, see Table 6-1.

Figure 6-13 Icons

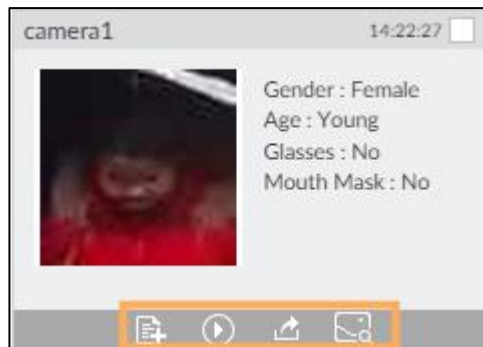








Table 6-1 Description

Icon	Operation
	<ul style="list-style-type: none"> Select one by one: Click the panel or move the mouse pointer onto the panel, and then click to select the panel. means it is selected. Batch select: Check All to select all panels on the interface.
	Click or double-click the panel, the system starts to play back the recorded videos (about 10 s).
	Click to quickly add the image to the face database. See "6.3.3.2.3 Adding from Detection Snapshots" for detailed information.

Icon	Operation
	<ul style="list-style-type: none"> Export one by one: Click  to export picture, video and excel. For details, see "6.2.4.3 Exporting Face Records." Export in batches: Select the panel and click  to export picture, video and video player. For details, see "6.2.4.3 Exporting Face Records." <p> After setting alarm linkage snapshot, during exporting images, the system exports detected images and panoramic images at the time of snapshot.</p>
	<p>Click , and then the system automatically searches all channels for the records of the current face.</p>

6.2.4.2 Searching by Image

Upload a face picture to search for similar faces.

You can select the to-be-uploaded face picture from local files or the face database.


- When you use face database images to search, ensure face database has been configured. See "6.3.3 Configuring Face Database" for detailed information.
- If you want to use the local images, you need to obtain the face image and saved it in the corresponding path.
 - ◇ When operating on the local interface, save the image in the USB storage device and then connect the USB storage device to the IVSS.
 - ◇ When operating on the Web interface or PC client, save the image on the PC in which the Web or PCAPP is located.



The function of search by image is not available with AI-by-camera.

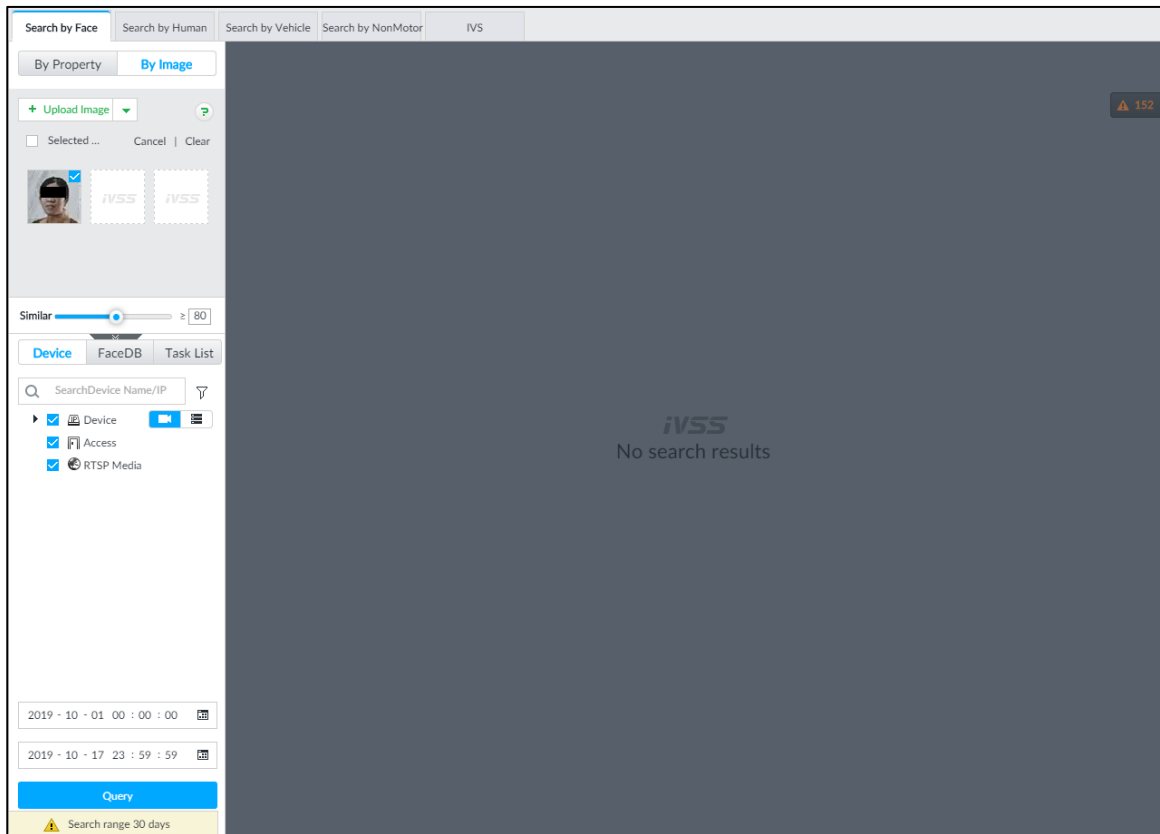
6.2.4.2.1 Searching Devices

Upload face image, compare it with face detection result of remote device, and find face detection information that meets the set similarity.

Step 1 On the **LIVE** interface, click , and then select **AI SEARCH > Search by Face > By Image**.

The **By Image** interface is displayed. See Figure 6-14.

Figure 6-14 Search by image



Step 2 Click the **Device** tab.

Step 3 Upload a face image.



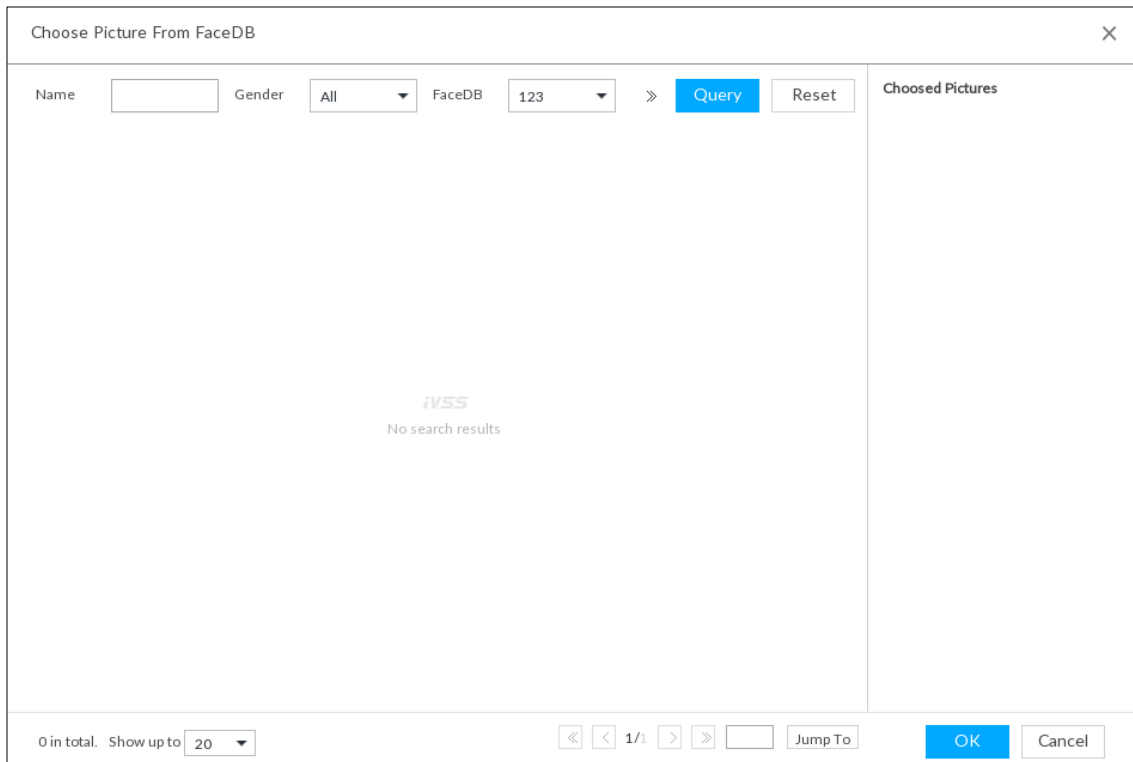
Device supports to upload maximum 50 face images. Device supports to select maximum 10 face images at one time.

- Upload the image from the face image database to search corresponding face.

1) Click  and select **Face DB**.

The **Choose Picture From Face DB** interface is displayed. See Figure 6-15.

Figure 6-15 Choose picture from face database





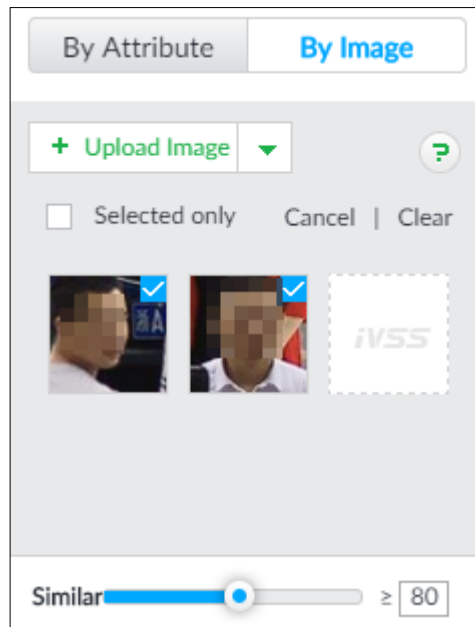

- 2) Select face database and then set search criteria.
 - ◇ If there are too many face images on the database, set name, gender to filter.
 - ◇ Click » to set the search ID number.
 - 3) Click **Query**.
Device displays the searched face images.
 - 4) Select face image.
The selected face image is displayed on the **Chosen Pictures** on the right side.
 - 5) Click **OK** to upload face image.
 - Local image: Upload images from the client PC or USB storage device connected to the Device.
- 1) Move the mouse to  and select **Local**.
 - 2) Select the face image you want to upload.

You can select several face images at the same time.
 - 3) Click **OK** to upload face image.
After uploading the images, device displays the face images on the top left corner. The latest 10 images are selected. See Figure 6-16.

Figure 6-16 By image



- When the uploaded image is half-length photo or full-body photo, the system automatically selects the frame of the uploaded image and only the face area will be retained.
- When there are multiple faces in the uploaded images, the system automatically identifies the faces in the images and uploads multiple face images according to the number of faces recognized.
- Device supports to select maximum 10 face images.
- Click **Cancel** to cancel all checked face images.
- Select **Selected only**, device displays checked human face images only.
- Click **Clear** to clear all uploaded face images.

Step 4 Hold on and drag  to set human face similarity. It is 80% by default.

Step 5 Select remote device on the device list and then set record file time period.

Step 6 Click **Query**.

The result is displayed. See Figure 6-17 and Table 6-2.

Figure 6-17 Query

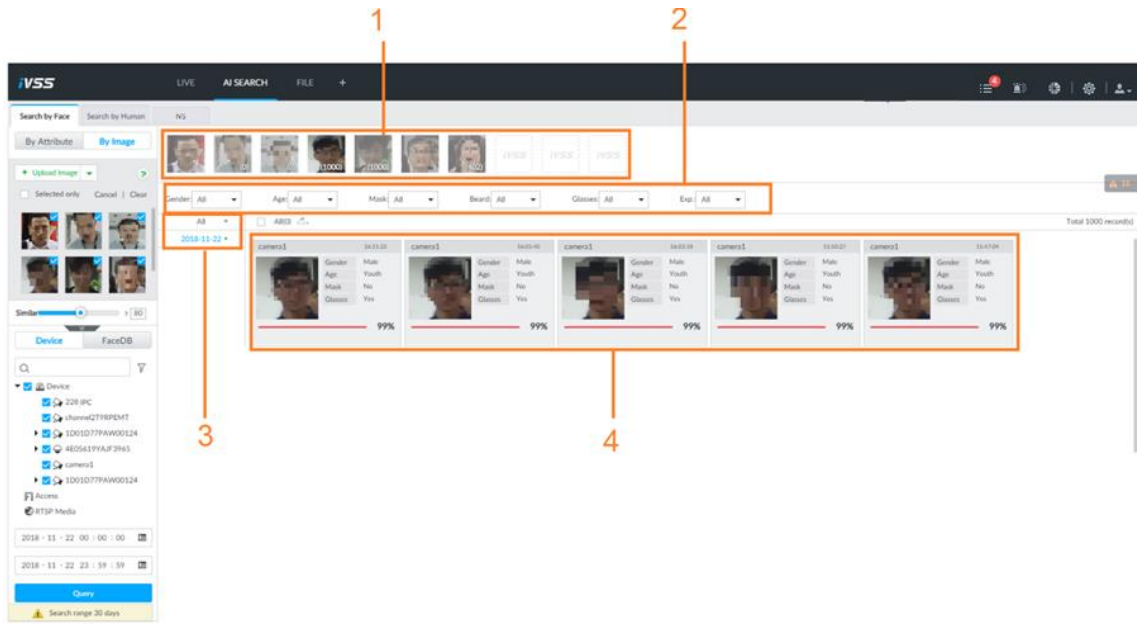


Table 6-2 Device search description

No.	Description
1	Displays selected face images. The number at the lower-right of the face image is to display the searched image amount. Click one image to view its query result.
2	Set filter criteria. It can quickly search the required image according to the face features.
3	Displays searched schedule list. Click a date, you can view the image list on current date on the right panel.
4	Displays the searched face panel, including face image, feature property and similarity.

6.2.4.2.2 Searching Face Database

Upload face image, compare it with face image in face database, and find face image that meets the set similarity.

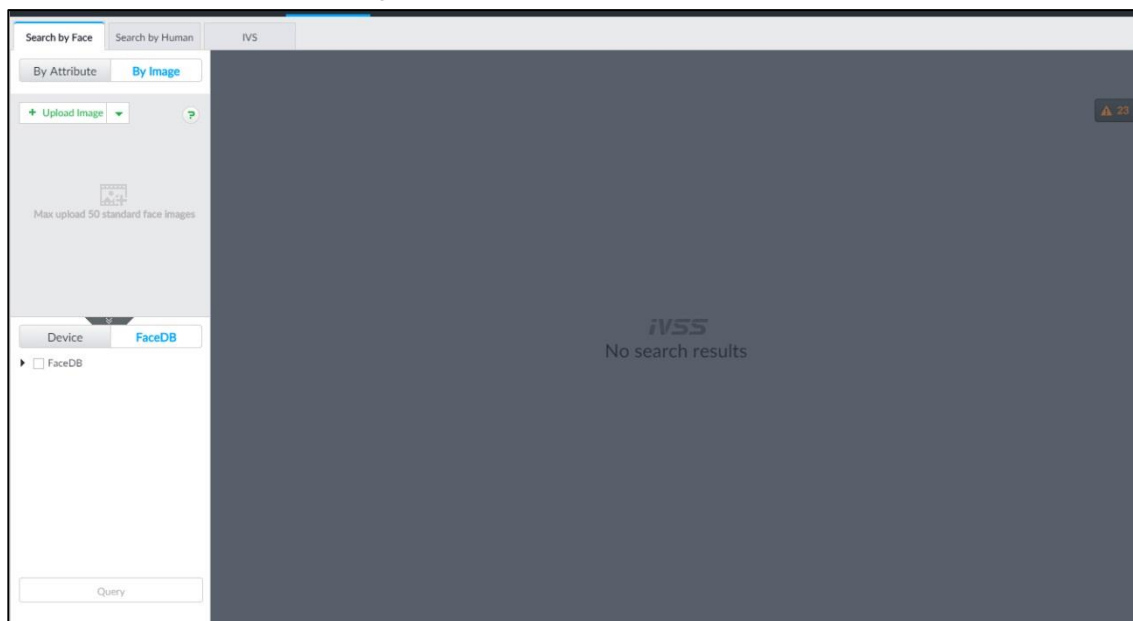
Step 1 On the **LIVE** interface, click **+**, and then select **AI SEARCH > Search by Face > By Image**.

The **By Image** interface is displayed.


Step 2 Click the **FaceDB** tab.

FaceDB interface is displayed. See Figure 6-18.

Figure 6-18 Face database



Step 3 Upload face image. See "6.2.4.2.1 Search Step 3" for detailed information.

Step 4 Hold on and drag  to set human face similarity. It is 80% by default.


Step 5 Select the face database.

Step 6 Click **Query**.

The result is displayed. See Figure 6-17. For details, see Table 6-2.

6.2.4.2.3 Searching Task Lists

Upload face pictures to search the AI video records for similar faces. For details about AI tasks, see "9.2 Task Management."

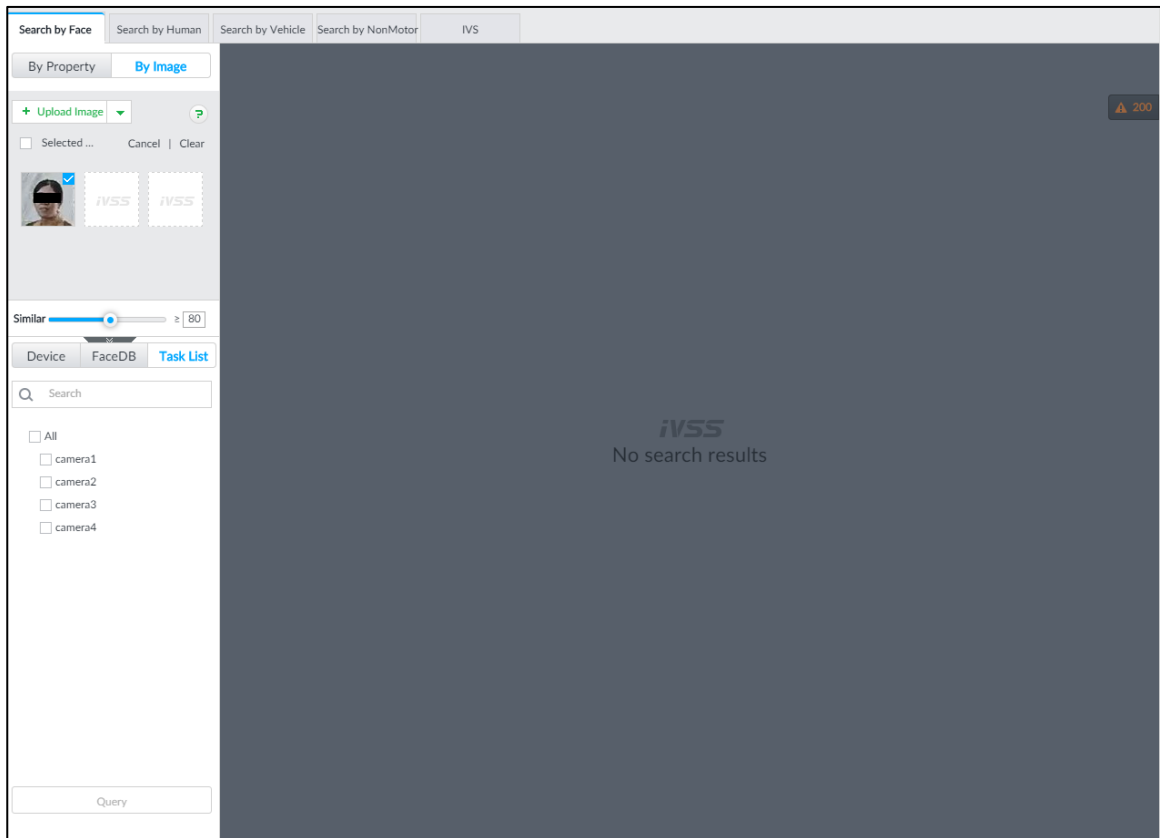
Step 1 On the **LIVE** interface, click , and then select **AI SEARCH > Search by Face > By Image**.

The **By Image** interface is displayed.


Step 2 Click the **Task List** tab.

The **Task List** interface is displayed. See Figure 6-19.

Figure 6-19 Task list



Step 3 Upload a face picture. For details, see Step 2 in "6.2.4.2.1 Searching Devices."

Step 4 Drag  to set similarity. It is 80% by default.

Step 5 Select one or more tasks.

Step 6 Click **Query**.

The result is displayed. See Figure 6-17. For details, see Table 6-2.

6.2.4.3 Exporting Face Records

The search results of face records can be exported. You can select to export video, picture and excel that contains detailed information.

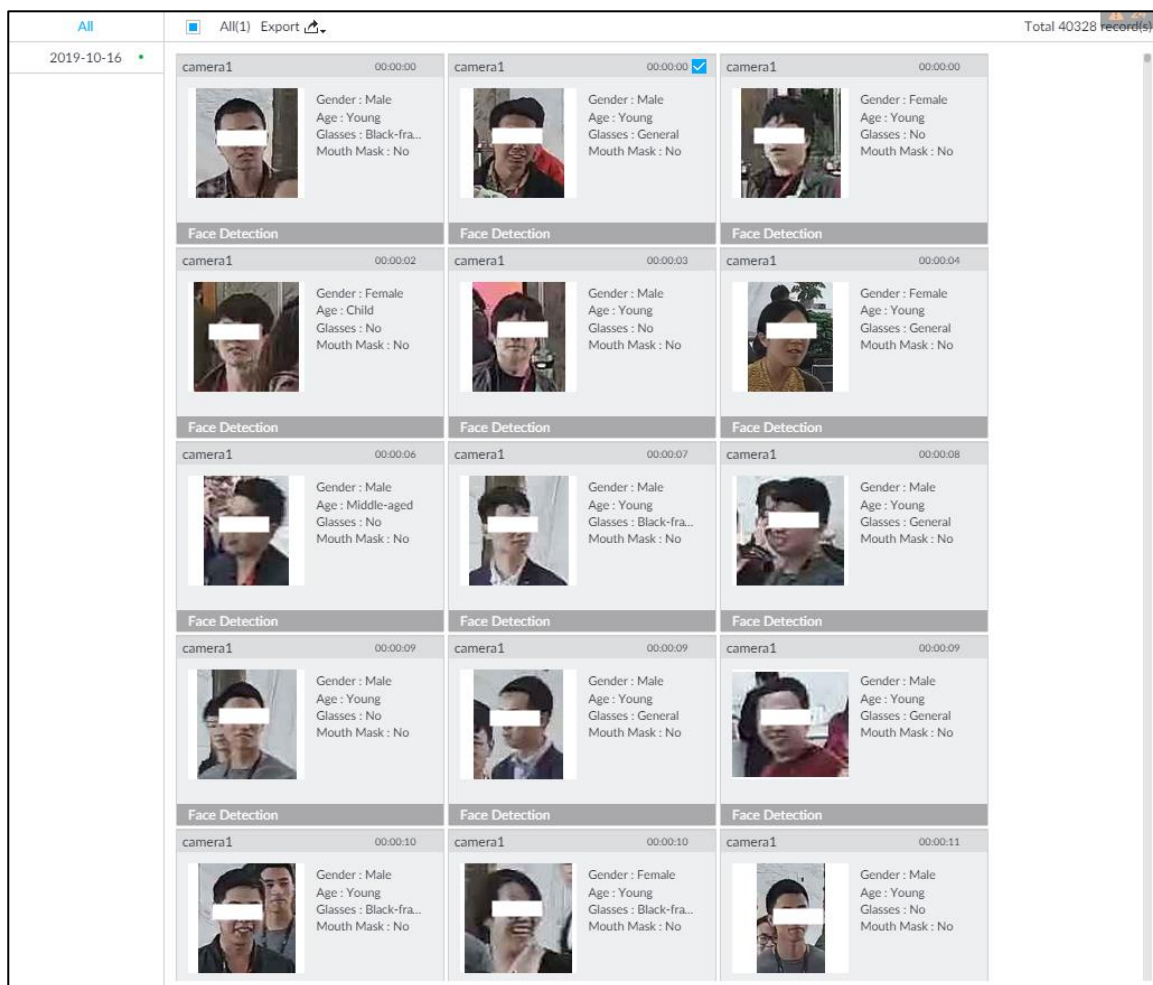
You can only export face records in the results of searching by property. For details about searching by property, see "6.2.4.1 Searching by Property."



- Make sure that you have inserted USB storage device into your IVSS.
- The exported alarm-linked snapshot contains the face snapshot and the background picture.
- To save the background picture, make sure that you have configured alarm-linked snapshot storage.

The search results are displayed as follows. See Figure 6-20.

Figure 6-20 Search results of face records



- Export in batches

Export more than one record. Support specifying file formats.

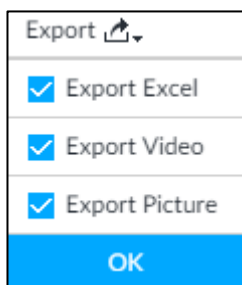
Step 1 Select more than one record.



To export all records, select the check box of **All**.

Step 2 Click , and then select file formats. See Figure 6-21.


Figure 6-21 File format



Step 3 Click **OK**, and then follow the onscreen instructions to finish exporting.

- Export one by one

Export one piece of record. The exported file contains picture, video and video player by default.

Step 1 Point to a piece of record, and then click .

The **Save** interface is displayed.

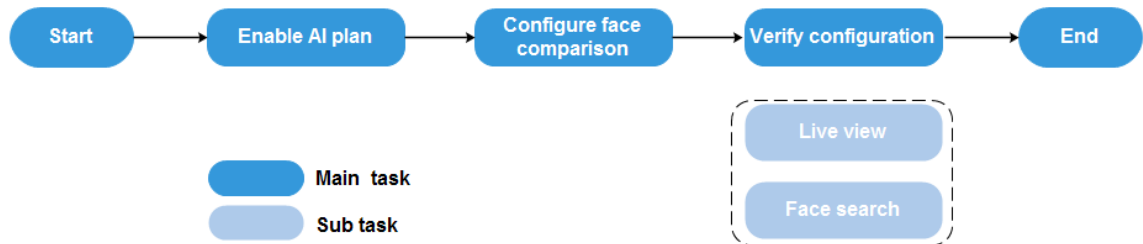
Step 2 Select a file type between DAV and MP4, set the saving path, and then click **OK**.

6.3 Face Recognition

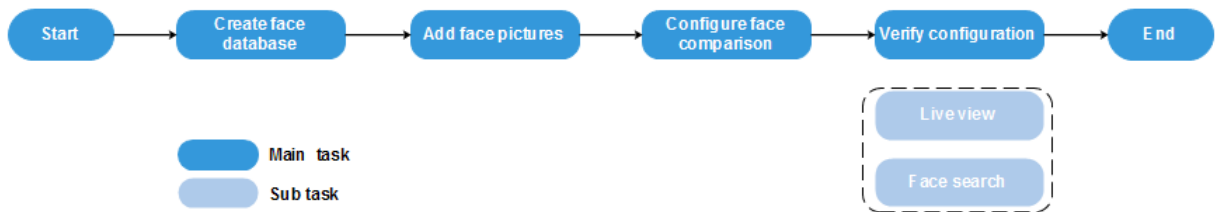
The system compares captured face with the face database and works out the similarity. When the similarity reaches the threshold as you have defined, an alarm will be triggered.

6.3.1 Configuration Procedure

Figure 6-22 Face recognition procedure (AI by camera)



Face recognition procedure (AI by device)



6.3.2 Enabling AI Plan

To use AI by camera, you need to enable the corresponding AI plan first. For details, see "6.2.1 Enabling AI Plan."


6.3.3 Configuring Face Database

You can create the face database to save face image, and the intelligent detection function can trigger the face database to carry out human face recognition, human face search, and so on.

6.3.3.1 Creating Face Database

Create human face database to sort out and manage the face images uploaded to the device.

Creating human face database

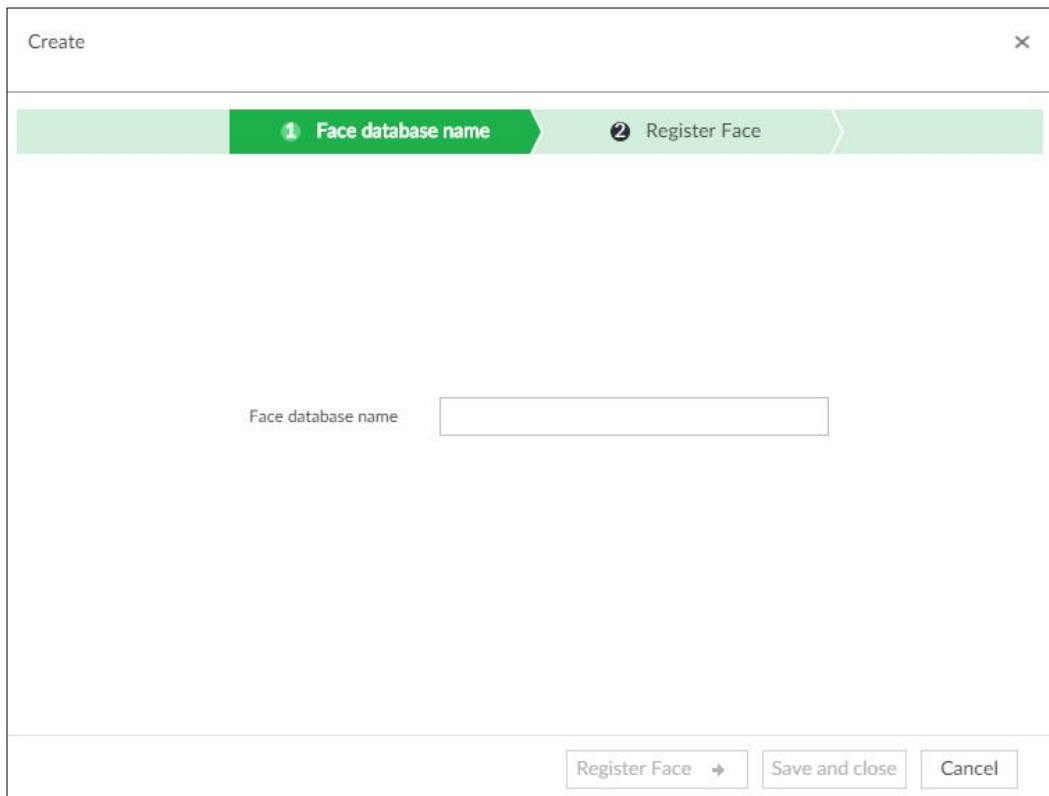
Step 1 On the **LIVE** interface, click , and then select **FILE > Face Management > Face Database**.

The **Face Database** interface is displayed.

Step 2 Click **Create**.

The **Create** interface is displayed. See Figure 6-23.

Figure 6-23 Create face database



The screenshot shows a dialog box titled "Create" with a close button (X) in the top right corner. Below the title bar is a progress indicator with two steps: "1 Face database name" (highlighted in green) and "2 Register Face". The main area of the dialog contains a text input field labeled "Face database name". At the bottom right, there are three buttons: "Register Face" with a right-pointing arrow, "Save and close", and "Cancel".

Step 3 Set face database name.

Step 4 Click **Register Face** or **Save and close**.

- Click **Register face**, and then add human face on the newly created human database. See Figure 6-24. See "6.3.3.2 Adding Face Image" for detailed information.

Figure 6-24 Register face

- Click **Save and close** to create a human face database with no data. After creating face database, you can go to the **Face Database** interface to view the newly created face database information. See Figure 6-25. For details, see Table 6-3.

Figure 6-25 Face database

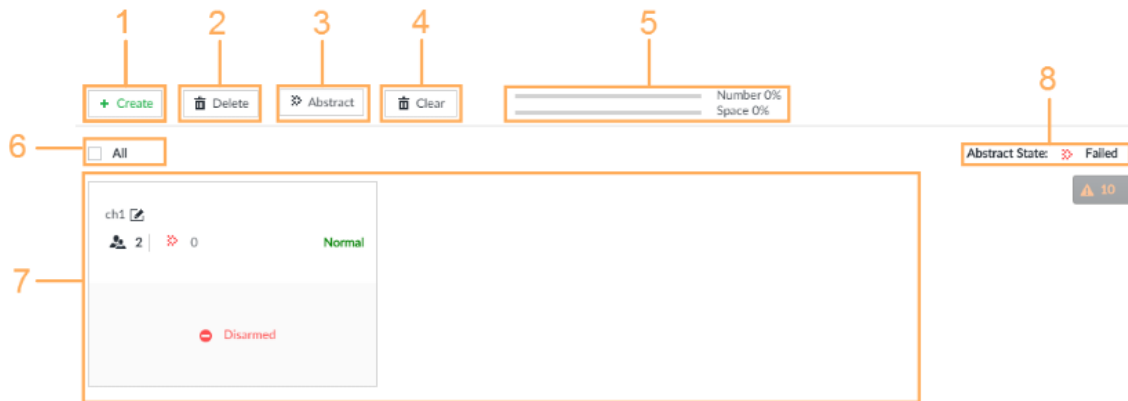



Table 6-3 Description








No.	Description
1	Click Create to create a face database. For details, see "6.3.3.1 Creating Face Database."
2	To delete a face database, select it and click Delete .
3	Select a face database and click Abstract for face moduling.
4	To clear a face database, select it and click Clear .

No.	Description
5	Display number and space information of face database. <ul style="list-style-type: none"> • Number: The percentage ratio of the added face image quantity to the allowable total quantity of face image. Device supports maximum 300,000 face images. • Space: The percentage ratio of the file size of added face images to the allowable total space for face image storage.
6	Check All button to select all face databases.
7	Display the list of created databases.
8	Display abstract state.  0 displays face image of current database that failed to abstract.

Other Operations

You can modify database name, upload face images to database, arm or delete the database, after the database is created. See Table 6-4 for detailed information.

Table 6-4 Operation of face database

Name	Operation
View face database information and state.	View face database information and state in face database zone. <ul style="list-style-type: none"> •  Set Human face database name. •  3945 is to display face image of current database. •  0 is to display human face that failed abstracting. See "6.3.3.3 Human Face for detailed information. •  means current face database has not connected to the corresponding channel to compare human face. After arm, the interface can display the remote device that is connected with the face database.
Change face database name.	Click  to change face database name.
Managing Face Image	Double-click face database to enter face database interface and manage face images. For details, see "6.3.3.4 Managing Face Pictures."
Arming Face Database	Link the face database to compare faces, and arm the face database. For details, see "6.3.3.4 Managing Face Pictures."
Deleting Face Database	<ul style="list-style-type: none"> • Delete: Move the mouse pointer to the face database and click  at the top right corner of the face database to delete. • Batch delete: Move the mouse pointer to the face database and then click  at the top left corner of the face database. Select several face databases at the same time and then click Delete to delete them. • Check All box and then click Delete to delete all face database.

6.3.3.2 Adding Face Image

Add face images to the created face database in the way of manual add, batch import or detection.




Make sure that you have obtained the face image and saved it in the proper path.

- When operating on the local interface, save the image in the USB storage device and then connect the USB storage device to the IVSS.
- When operating on the Web or IVSS interface, save the image on the PC in which the Web or PCAPP is located.

6.3.3.2.1 Manual Add

You can add human face image one by one. If the registered human face image quantity is small, you can use manual add mode.

Step 1 On **LIVE** interface, click , and then select **FILE > Face Database**.

Face Database interface is displayed.

Step 2 Double-click face database.

Face database interface is displayed. See Figure 6-26.

Figure 6-26 Manual add



Step 3 Click **Manual Add**.


The **Face Register** interface is displayed. See Figure 6-27.

Figure 6-27 Face register

Face Register

Name

Gender Male Female

Birthday - - 

Country or Region ▼

Address

ID Type ▼

ID No.

Step 4 Click  and select face image.

The **Confirm Choice** interface is displayed. See Figure 6-28.



- When the uploaded image is half-length photo or full-body photo, the system automatically selects the frame of the uploaded image and only the face area will be retained.
- When there are multiple faces in the uploaded images, the system automatically identifies the faces in the images and uploads multiple face images according to the number of faces recognized. See Figure 6-29. Select face image you want to upload. Blue frame means that it is selected.
- Click **Cancel** to cancel all checked face images.

Figure 6-28 Confirm choice (1)

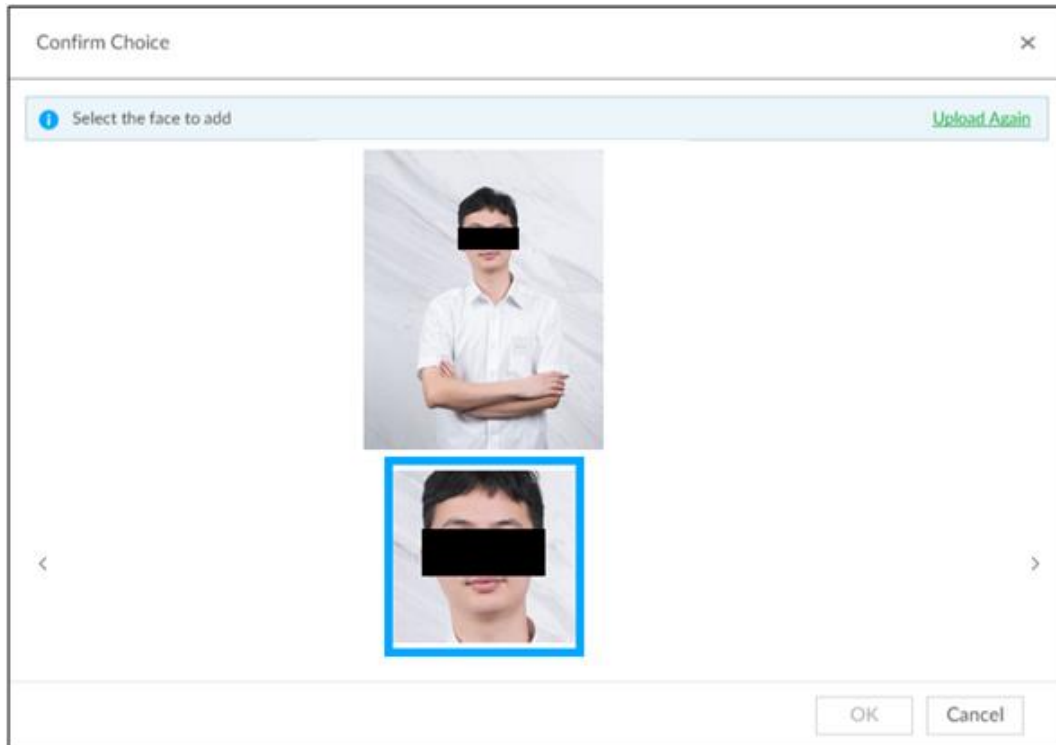
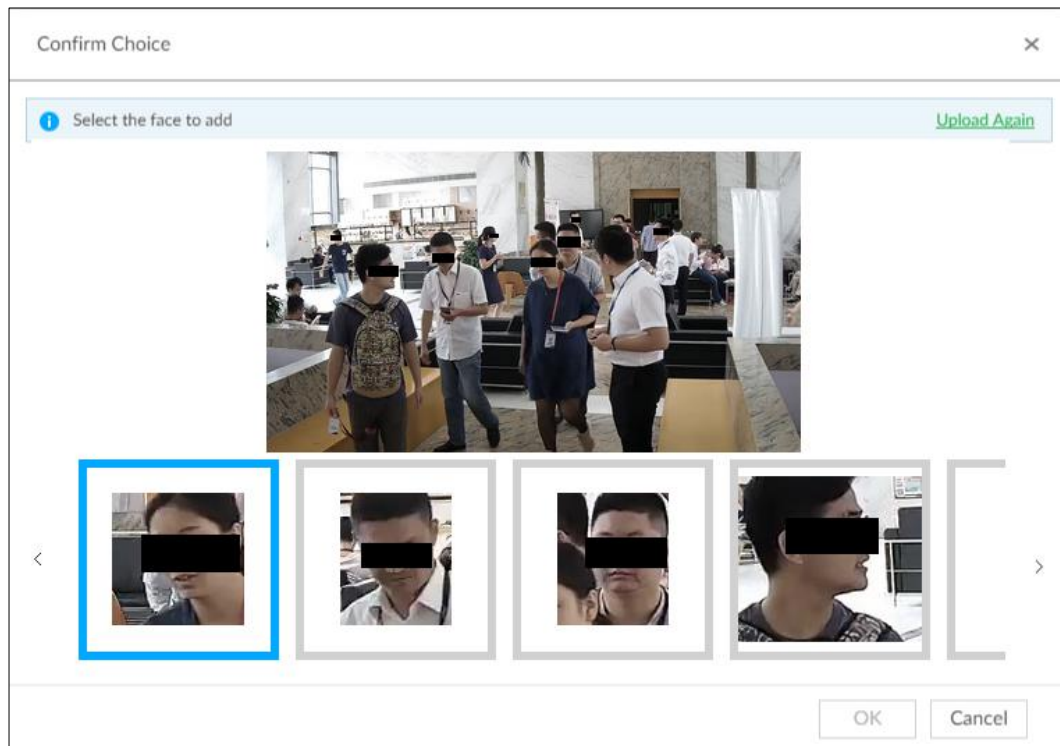


Figure 6-29 Confirm choice (2)



Step 5 Click **OK** and import face image.

The **Face Register** interface is displayed. See Figure 6-30.



Move the pointer to the face image and click **Change Picture** to change it.

Figure 6-30 Face register

Step 6 Fill in face image information.

Step 7 Click **Save and continue** or **OK**.

- Click **Save and Continue to add** to save current face image information and add another human face image.


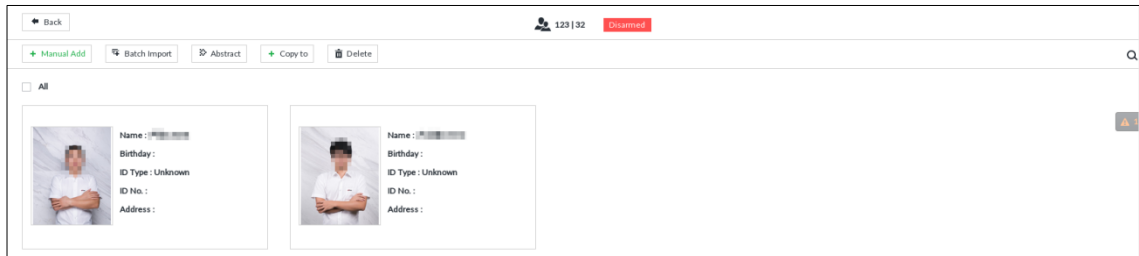
- Click **OK** to save current face image information and complete registration. After adding the image, at the lower-left corner of the human face image, there is an icon . It means device that face abstracting in process. See Figure 6-31. See "6.3.3.3 Human Face Abstract" for detailed information.

Figure 6-31 Manual add



6.3.3.2.2 Batch Import

Batch import is to import multiple face images at the same time by uploading file or uploading folder. If you want to register a large number of face images, batch import is recommended.

Preparation

Before the batch import, name the face image according to the following rule: "Name#S#Gender#B#Birthday#N#Nation#P#Province#T#IDtype#M#IDnumber#A#Address.jpg" (such as "Tim#S1#B20000101#NCN#PZheJiang#T1#M0000#A#Address").

Name the face image according to the rule. After successful import, the system will identify the face image automatically. For details about naming rule, see Table 6-5.



Name is required and the rest are optional. For example, if you want to enter the name and ID number only, the naming can be Tim#S#B#N#P#T#M0000#A.jpg or Time#M0000.jpg.

Table 6-5 Naming rules for batch import

Item	Description
Name	Enter the corresponding name.
Gender	Enter number. 1: Male; 2: Female.
Birthday	Enter number in the format of yyyyymmdd or yyyy-mm-dd. For example, 20181123.
Abbreviation of countries/regions	Enter the corresponding abbreviation of the nation/region.
Province	Enter the corresponding spelling or English name of the province.
ID type	Enter the corresponding number. 1. ID card, 2. Passport, 3. Officer Card.
ID number	Fill in the corresponding ID number.
Address	Enter the detailed address.

Operation Steps

Step 1 On the **LIVE** interface, click , and then select **FILE > Face Database**.

Face Database interface is displayed.

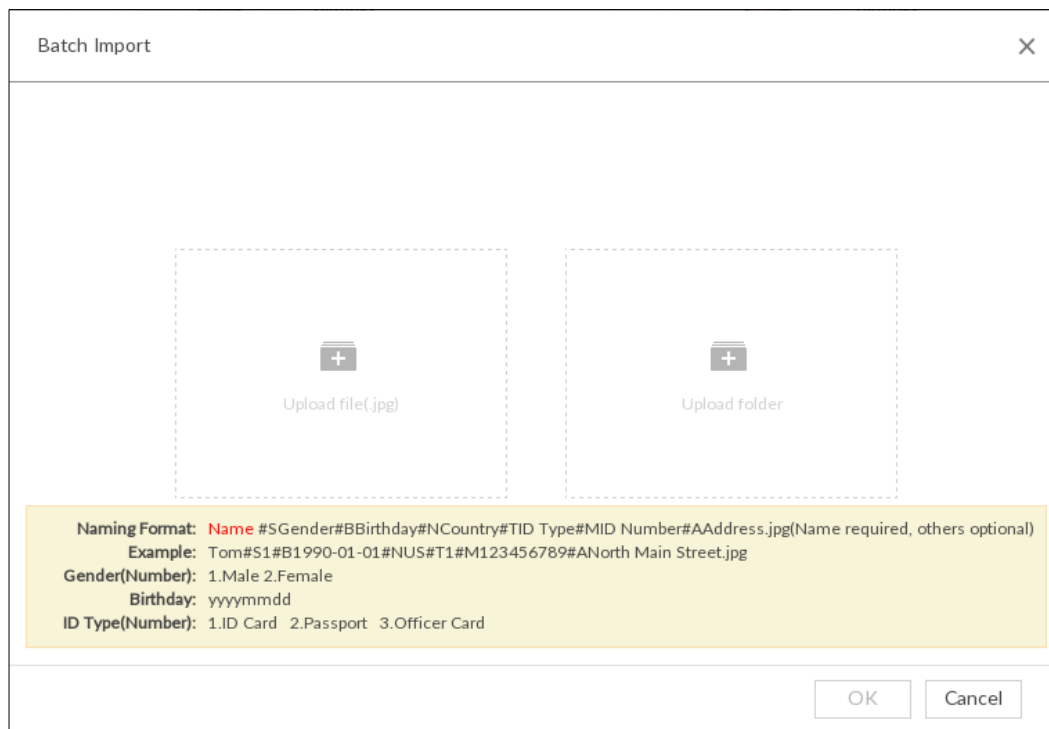
Step 2 Double-click face database.

The face database interface is displayed.

Step 3 Click **Batch Import**.

The **Batch Import** interface is displayed. See Figure 6-32.


Figure 6-32 Batch import



Step 4 Import face image.


The system supports to upload file and folder. Select according to your actual need.

- Upload File

- 1) Click  to select multiple face images.
 - ◇ Press and hold **Shift**, click any two images, so both images and all images between them can be selected.
 - ◇ Press and hold **Ctrl**, click multiple face images to select them.

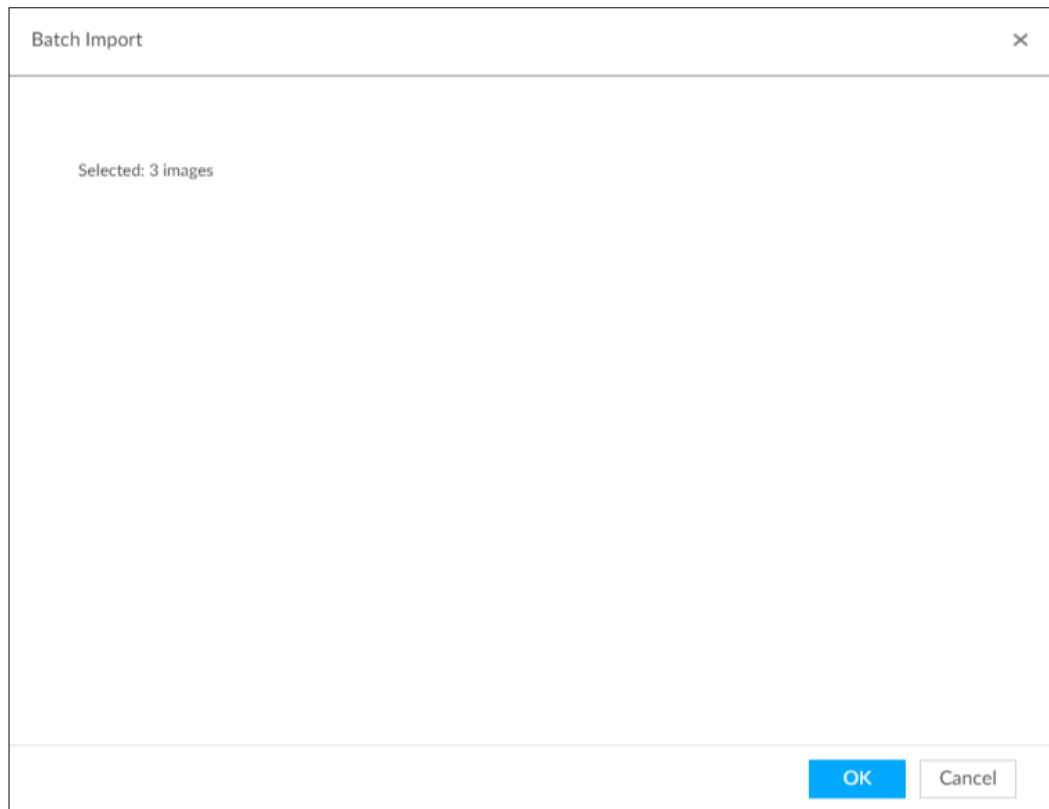
- 2) Click **Open**.

- Upload Folder

- 1) Click  and select the folder where there are face images.
- 2) Click **OK**.

The number of face images is displayed. See Figure 6-33.

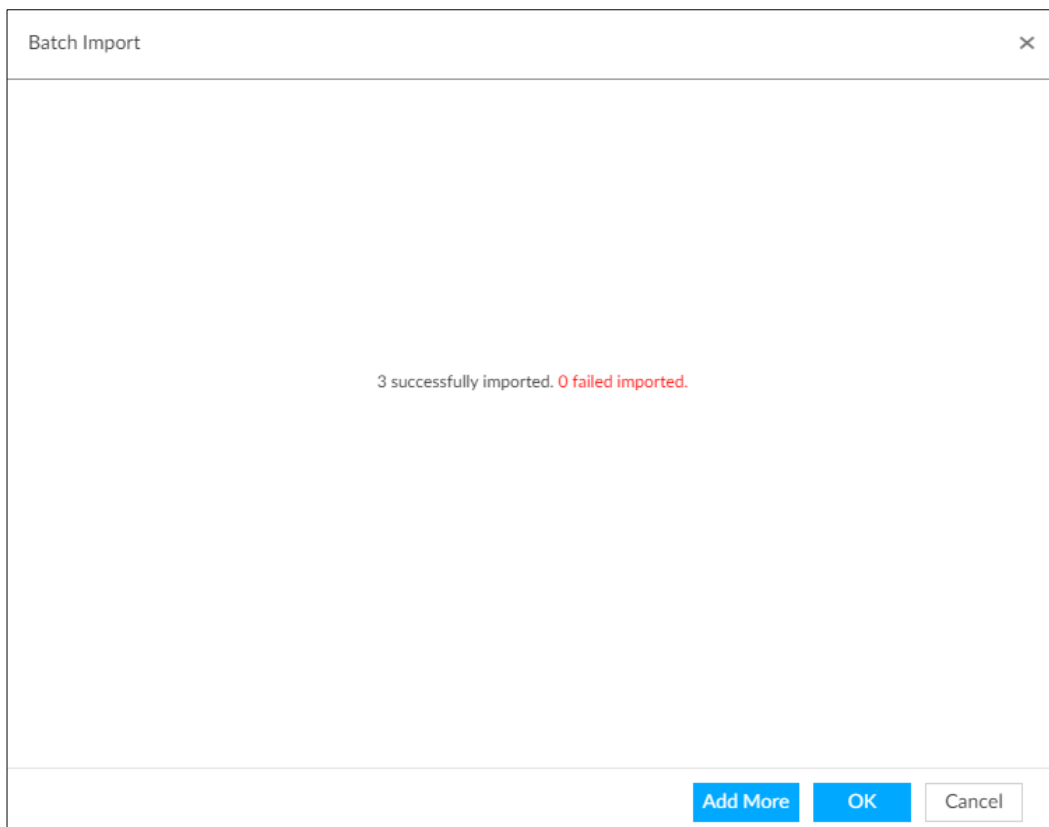
Figure 6-33 Batch import



Step 5 Click **OK**.

The batch import result interface is displayed. See Figure 6-34.

Figure 6-34 Batch import



Step 6 Click **Continue to add** or **OK**.

- Click **Continue to add** to add more images.

- Click **OK** to complete adding images. Face database interface is displayed, and you can see the added images. See Figure 6-35.


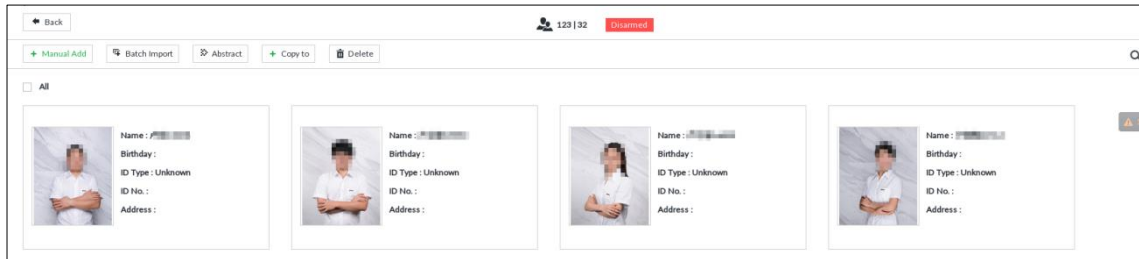
After adding the image, at the lower-left corner of the face image, the icon  appears, which indicates that face information is being processed. See "6.3.3.3 Human Face for detailed information.

Figure 6-35 Face database






6.3.3.2.3 Adding from Detection Snapshots

Add the snapshot of AI detection to the created face database.

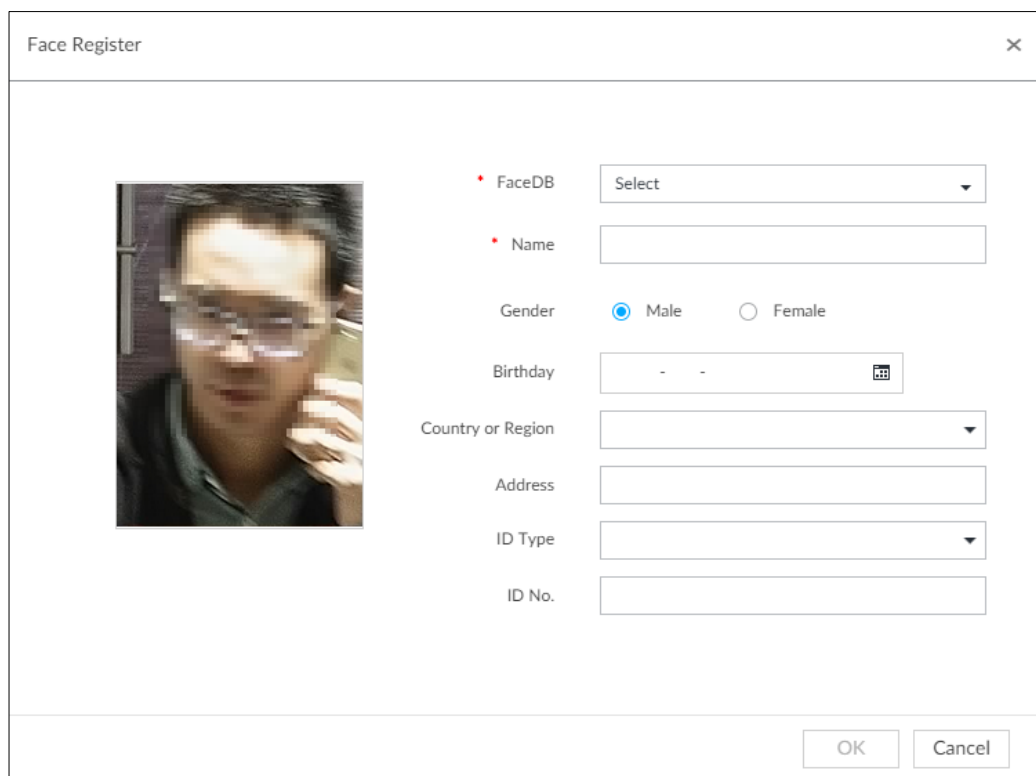
Step 1 Select face images on the **LIVE** interface.

The following two ways are available.

- Point to a face snapshot in the refreshing snapshot list on the right of the live video, and then click .
- Click  64841, point to a face snapshot, and then click .

The **Face Register** interface is displayed. See Figure 6-36.

Figure 6-36 Face register



Step 2 Select a face database, and fill in person information according to your actual situation.


Step 3 Click **OK** to save the configuration.

6.3.3.3 Human Face Abstract

The human face abstracting is to abstract the corresponding information of the face image and import to the database. After that, device can compare human face, and search human face.



- The greater the face image quantity is, the longer the face abstracting time it takes.
- During the abstracting process, some intelligent functions (such as human face recognition, search human face and so on.) are null. These functions become normal after the abstracting process is completed.
- When the uploaded image is half-length photo or full-body photo, the system automatically selects the frame of the uploaded image and only the face area will be retained.

Step 1 On the **LIVE** interface, click , and then select **FILE > Face Management > Face Database**.

The **Face Database** interface is displayed.

Step 2 Double-click a face database.

Step 3 Select face images and then click **Abstract**.

System pops up a confirmation box. See Figure 6-37.



TIPS


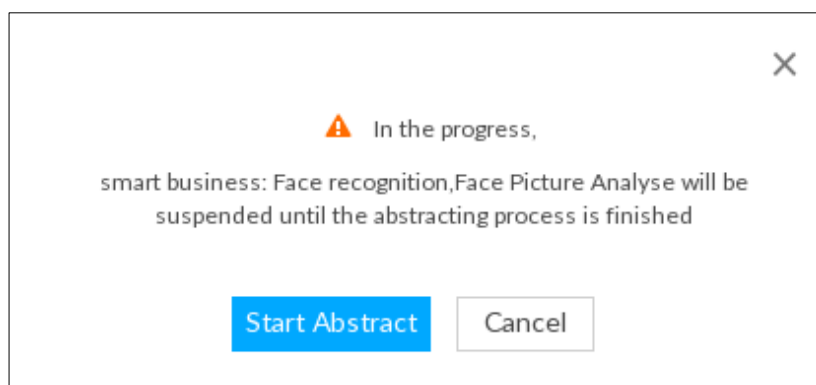
- Select **All** to select all face images on current human face database.
- If there are too many human face images on the human face database, click  to set search criteria (such as name, gender, birthday, country, province, ID type, ID number or abstracting status) to quickly find the human face images.

Figure 6-37 Prompt



Step 4 Click **Start Abstract**.

Device begins processing face information. See Figure 6-38.



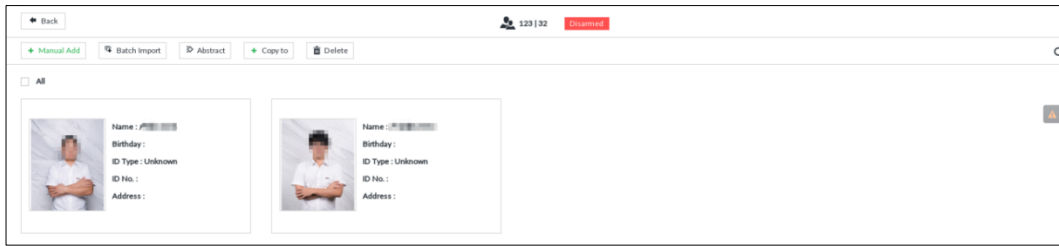
The abstracting is successful if  is no longer at the lower-left corner of the face image. The abstracting might fail if the face image is not clear or does not contain complete information, and  appears at the lower-left corner of the face image.

Figure 6-38 Abstract result

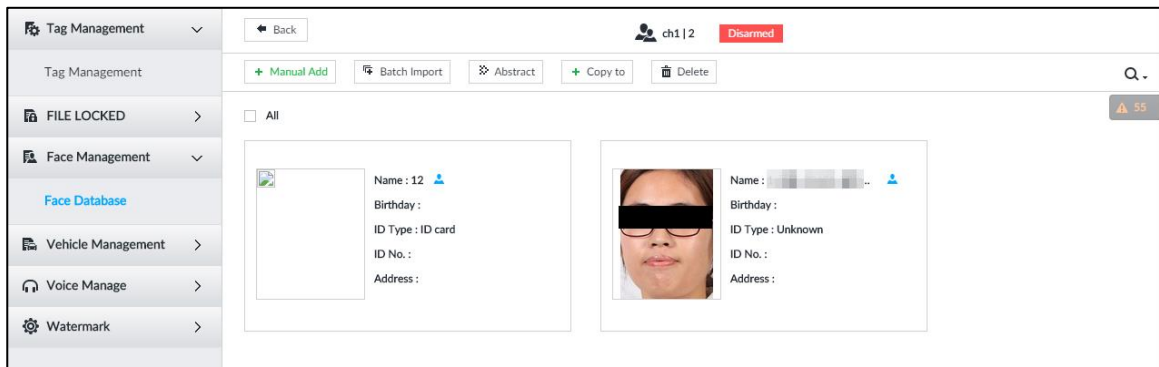


6.3.3.4 Managing Face Pictures


Maintain and manage face images in the face library to ensure that people information is always correct. The system supports editing face picture information, copying face pictures to other face database and deleting face pictures.

On the **LIVE** interface, click **+**, and then select **FILE > Face Management > Face Database**. Double-click a face database, the face pictures in the database are displayed. See Figure 6-36.

Figure 6-39 Face database



6.3.3.4.1 Editing Face Pictures

Step 1 In the face database, point to a face picture, and then click .

The **Edit Face** interface is displayed. See Figure 6-40.

Figure 6-40 Edit face pictures

Step 2 After editing, click **OK**.

6.3.3.4.2 Copying Face Pictures

Step 1 In the face database, point to a face picture, and then click to select the face picture.



- You can select more than one pictures.
- To select all pictures, click **All**.

Step 2 Click **Copy to**.

The **Copy to** interface is displayed. See Figure 6-41.

Figure 6-41 Copy to

Step 3 Select a face database.




- You can select more than one face databases.
- You can also select a face database by entering the database name in the **Face database** name box and clicking **Query**.
- Select the check box of **Retain Original Face** to keep the original face pictures in the database. It is selected by default.

Step 4 Click **OK**.

6.3.3.4.3 Deleting Face Pictures

Two ways to delete face pictures in the face database.

- One by one: Point to the face picture, and then click .
- In batches:
 - ◇ Point to the face picture, and then click . By the same way, select more pictures, and then click **Delete**. The selected face pictures are deleted.
 - ◇ Click **All**, and then click **Delete**. All the face pictures in this page are deleted.

6.3.4 Configuring Face Recognition

Configure face recognition rules.

To use AI by device, enable face detection first. For details, see "6.2.2 Configuring Face Detection."

Step 1 Click , or click  on the configuration interface, and then select **EVENT**.

The **EVENT** interface is displayed.

Step 2 Select remote device in the device tree on the left.

Step 3 Select **AI Plan > Face Recognition**.

The **Face Recognition** interface is displayed. See Figure 6-42 or Figure 6-43.

Figure 6-42 Face recognition (AI by Camera)

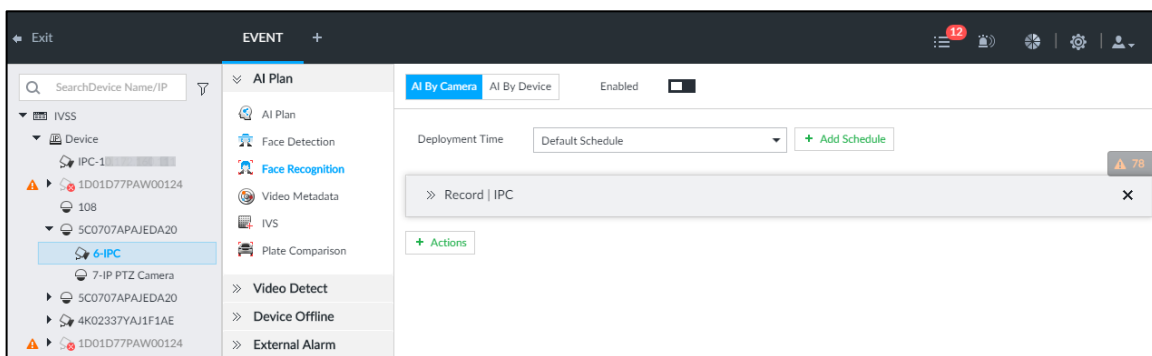
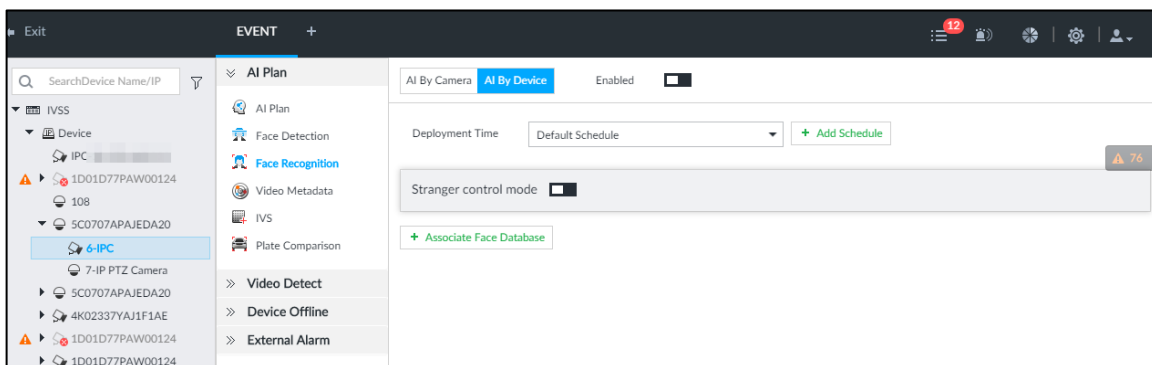


Figure 6-43 Face recognition (AI by Device)



Step 4 Click **AI by Camera** or **AI by Device**, and then click .

Step 5 Click **Deployment Time** to select schedule from the drop-down list.
 After setting arm period, system triggers actions when there is a motion detection alarm in the specified period.

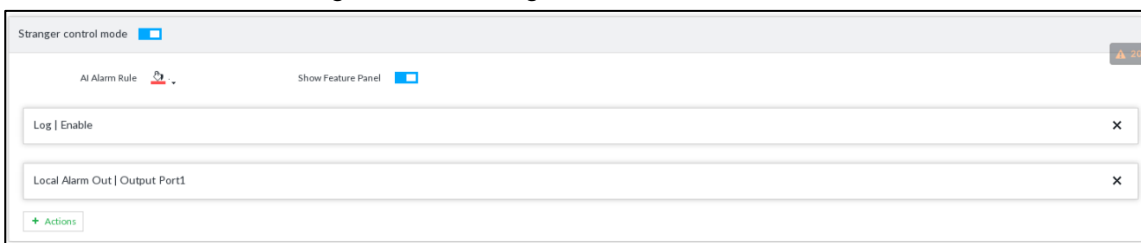
- Click **View Schedule** to view detailed schedule settings.
- If the schedule is not added or the added schedule does not meet actual needs, click **Add Schedule**. See "8.8.4 Schedule" for detailed information.

Step 6 Set stranger mode.
 Enable stranger mode. Once the face recognition similarity is lower than the specified value, system triggers an alarm.

1) Click to enable stranger mode.


The **Stranger control mode** interface is displayed. See Figure 6-44.

Figure 6-44 Stranger control mode



2) Set parameters. For details, see Table 6-6.

Table 6-6 Stranger control mode description

Parameters	Description
AI alarm rule	Click  to set alarm rule box color.

Parameters	Description
Show feature panel	Check <input type="checkbox"/> to enable features panel function. System displays stranger panel once there is an alarm.

3) Click **Actions** to set alarm actions. See "8.4.1 Alarm Actions" for detailed information.

Step 7 Set linked face database.

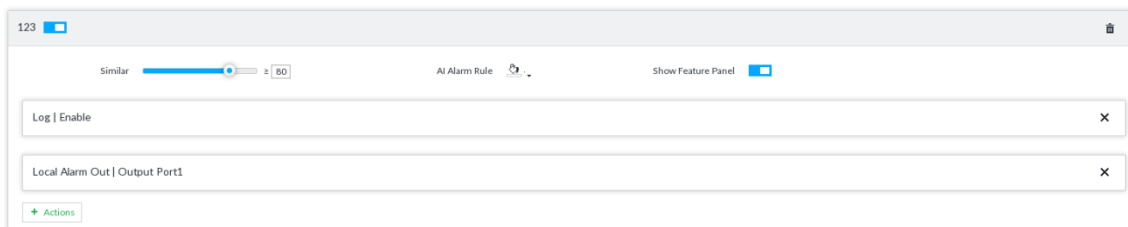


- Before you use AI by camera function, go to the remote device to set face database. On IVSS interface, set alarm activation event.
- Repeat the step to trigger several human databases at the same time.

1) Click **Associate Face Database**, and then select the triggered human face database.


Face database configuration interface is displayed. See Figure 6-45.

Figure 6-45 Face database configuration



2) Set parameters. For details, see Table 6-7.

Table 6-7 Configuration description

Parameters	Description
Similar	Set human face similarity. System compares the human face with the image on the face database. System triggers an alarm once the similarity reaches the threshold you set here.
AI alarm rule	Click  to set alarm rule box color.
Show feature panel	Click <input type="checkbox"/> to enable features panel function. System displays features panel once there is an alarm.

3) Click **Actions** to set alarm actions. See "8.4.1 Alarm Actions" for detailed information.

Step 8 Click **Save**.

6.3.5 Live View of Face Recognition

Smart panel display. You can view real-time face detection and human face recognition images.


6.3.5.1 Setting AI Display

You can configure display rule of AI detection results.



Before using this function, ensure that view has been created. See "7.1.1 View Management" for detailed information.

Step 1 On the **LIVE** interface, open a view window.

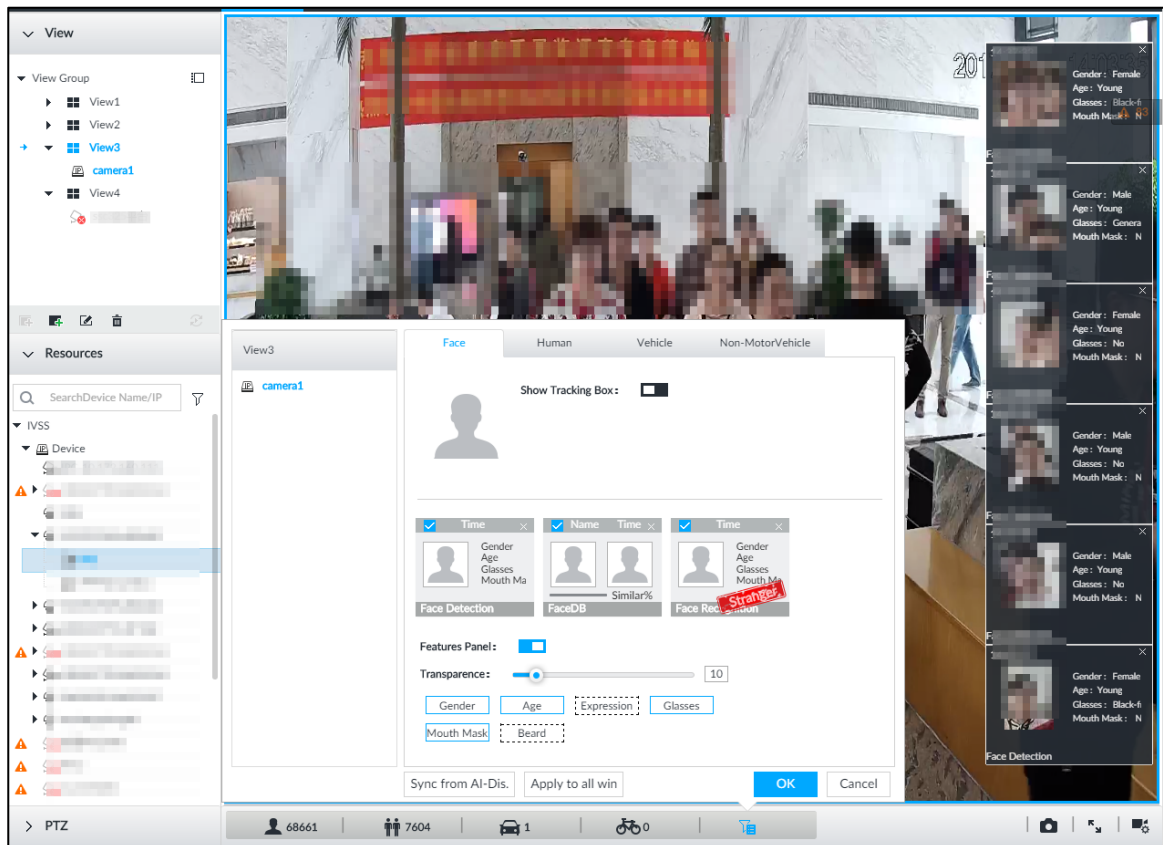
Step 2 Click  and select the **Face** tab.

The **Face** interface is displayed. See Figure 6-7.



- Click **Sync from AI-Dis.**, obtain global smart detection display rule of IVSS. See "8.4.2.3.2 Setting AI Display" for detailed information.
- Click **Apply to all windows** to copy current configuration to other window(s).



Figure 6-46 Face




Step 3 Enable **Show Tracking Box**.

After it is enabled, when the system detects face or human, the window will display corresponding rule box.

Step 4 Enable features panel.

- 1) Click  next to **Features Panel**, to enable the function. When the panel is enabled, the snapshots of detected faces are displayed on the live view.
- 2) Click  to select **Face DB** tab and **Face Recognition** tab. indicates that the panel is selected.
 - If the **Face DB** panel is selected, it is displayed on the live video when the similarity between a detected face and one in the face database reaches the threshold.

- If the **Face Recognition** panel is selected, it is displayed on the live video when the similarity between a detected face and one in the face database does not reach the threshold.
- 3) (Optional) Drag  to adjust features panel transparency. The higher the value, the more transparent the features panel.
 - 4) (Optional) Select the features you need to display.
 - System supports displaying 4 feature types.
 - System has checked four features by default. To select other features, cancel the selected features, and then select the ones you need.

Step 5 Click **OK** to save the configuration.

6.3.5.2 Live View

Go to the **LIVE** interface, enable view, and then device displays view video. See Figure 6-8.

- The view window displays currently detected face rule box.
- The right side displays features panel.
 - ◇ During face detection, features panel displays detection time, the detected face image and feature.
 - ◇ During face recognition, features panel displays detection time, the detected face image, face image in the database, comparison result and database name. After setting stranger mode, when the detected face image mismatches face image in the database, features panel will have Stranger tag.

Figure 6-47 Live



Point to a features panel, and then the operation icons are displayed. See Figure 6-9.

Figure 6-48 Face database



- Click to add this image to the face database. See "6.3.3.2.3 Adding from Detection Snapshots" for detailed information.
- Click or double-click the detected image, so the system starts to play back the recorded videos (about 10 s) at the time of snapshot.
- Click to search for similar faces.

6.3.5.3 Face Total

On the **LIVE** interface, click . Face detection panel is displayed. Click , and then **Face Recognition** and **Stranger**. The face recognition results are displayed. See Figure 6-49.

Figure 6-49 Detection image (1)



- Add the face image to the created face database.
Point to a piece of face record, and click to add this image to the face database. See "6.3.3.2.3 Adding from Detection Snapshots" for detailed information.
- Play the detection video.
Point to a piece of face record, and click or double-click the detected image, so the system starts to play back the recorded videos (about 10 s) at the time of snapshot.
- Export the record.
Point to a piece of face record, click , and then you can save the record, which contains video and picture.
- Search for similar target.
Point to a piece of face record, click , and then the system automatically searches for the similar faces in the defined period.




When operating on the IVSS device (not from the Web interface or PC client), make sure that you have connected the USB storage device.

6.3.6 Face Search

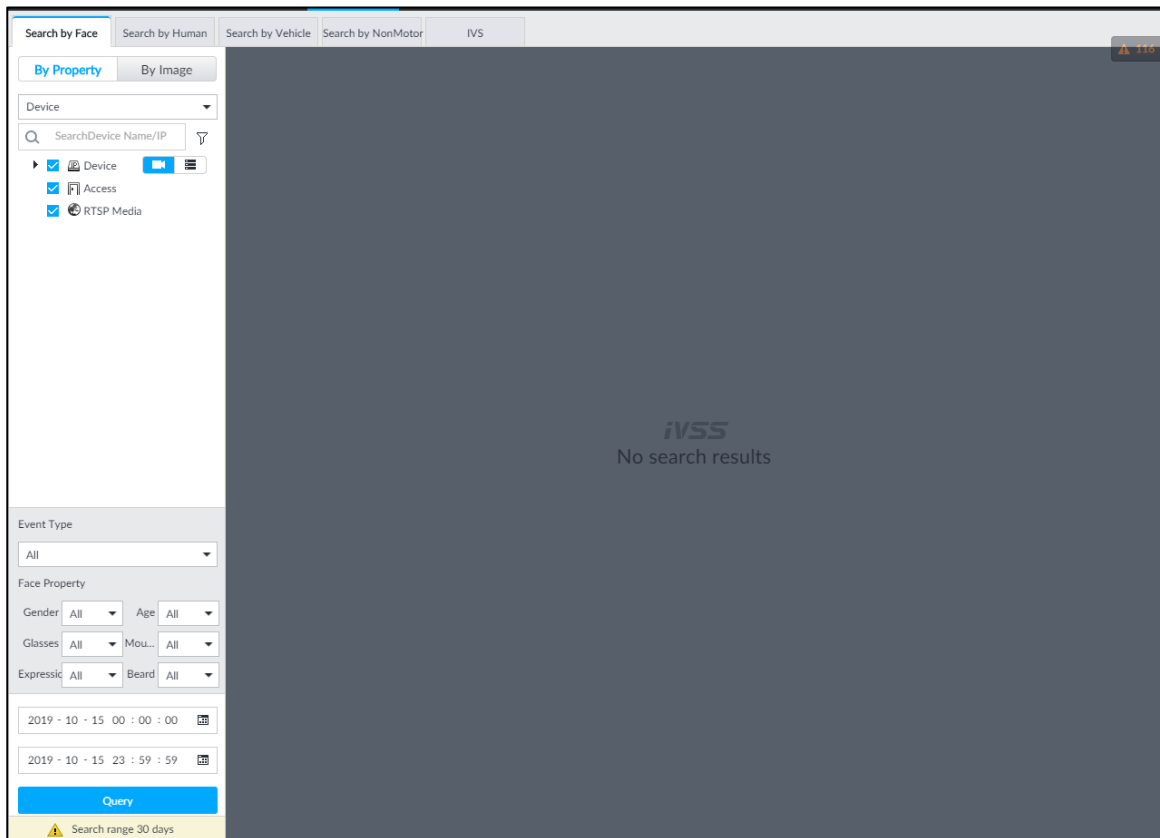
Search for face detection information, including face detection image, record and features. Search according to record and image.

6.3.6.1 Searching by Property

Step 1 On the **LIVE** interface, click , and then select **AI SEARCH > Search by Face > By Property**.

The **By Property** interface is displayed. See Figure 6-50.

Figure 6-50 Search by property



Step 2 Select a remote device, and then set **Event Type** to be **Face Detection**.



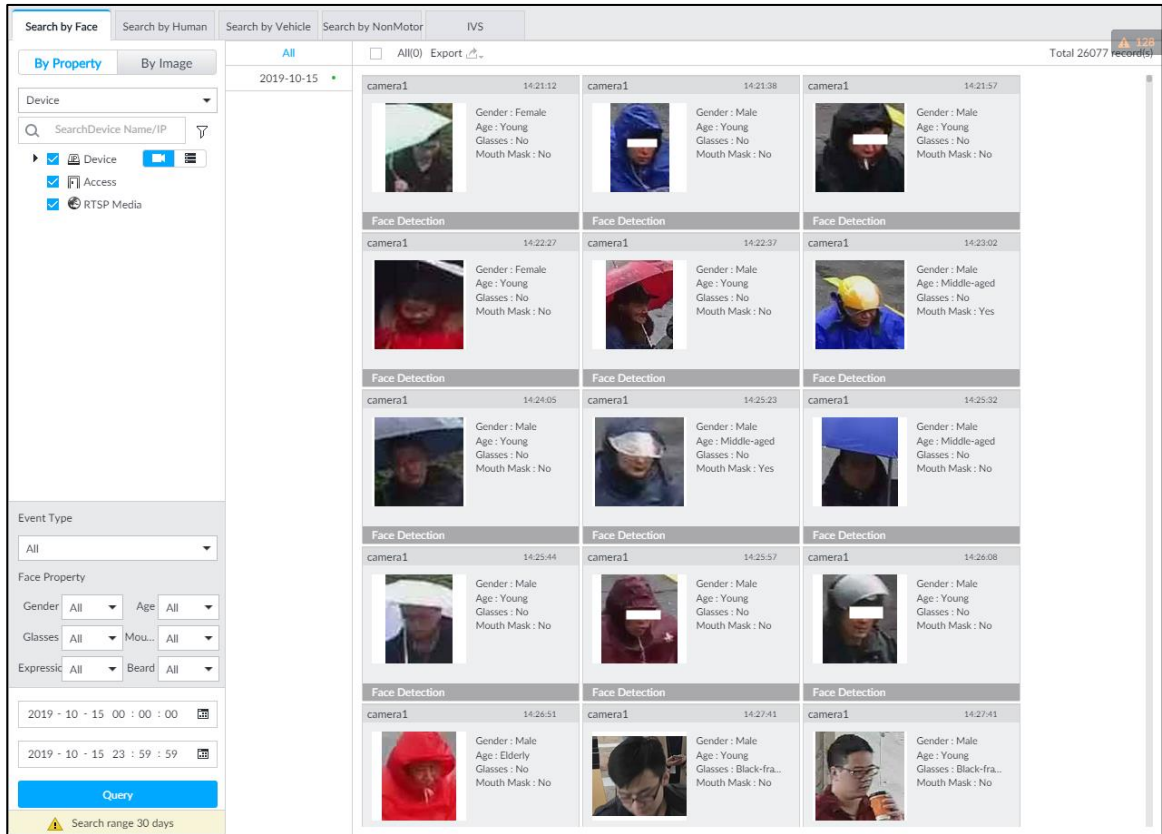
In the **Event Type** drop-down list, if you select **All**, the search results will include both face detection records and face recognition records.

Step 3 Set face property and time.

Step 4 Click **Query**.

The search results are displayed. See Figure 6-51.

Figure 6-51 Search results



Point to a piece of record, the following icons are displayed. See Figure 6-52. For details, see Table 6-8.

Figure 6-52 Icons

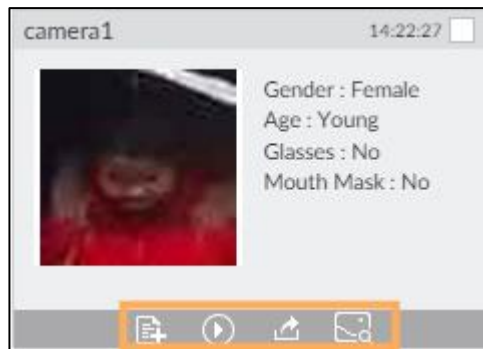








Table 6-8 Description

Icon	Operation
	<ul style="list-style-type: none"> Select one by one: Click the panel or move the mouse pointer onto the panel, and then click to select the panel. means it is selected. Batch select: Check All to select all panels on the interface.
	Click or double-click the panel, the system starts to play back the recorded videos (about 10 s).
	Click to add the image to the face database. See "6.3.3.2.3 Adding from Detection Snapshots" for detailed information.

Icon	Operation
	<ul style="list-style-type: none"> Export one by one: Click  to export picture, video and excel. For details, see "6.2.4.3 Exporting Face Records." Export in batches: Select the panel and click  to export picture, video and video player. For details, see "6.2.4.3 Exporting Face Records." <p> After setting alarm linkage snapshot, during exporting images, the system exports detected images and panoramic images at the time of snapshot.</p>
	Click  , and then the system automatically searches for the records of the most similar faces.

6.3.6.2 Searching by Image

Upload a face picture to search for the records of the same face. For details, see "6.2.4.2 Searching by Image"

6.3.6.3 Exporting Face Records

Export the searched face records, including pictures, videos and detailed information. For details, see "6.2.4.3 Exporting Face Records."

6.4 People Counting

This section introduces the statistics of in-area people number, and queuing number.



- The people counting function is only available with AI by camera. Make sure that the camera has been configured with people counting rules.
- The old people counting data will be overwritten when the storage space is runs out. You are recommended to back up the data in time.

6.4.1 Enabling AI Plan

To use AI by camera, you need first enable the corresponding AI plan; otherwise the AI function does not work. For details, see "6.2.1 Enabling AI Plan."

6.4.2 People Counting

The system counts the number of people in and out of the detection area. When the statistical number is larger or smaller than the threshold, an alarm is triggered.

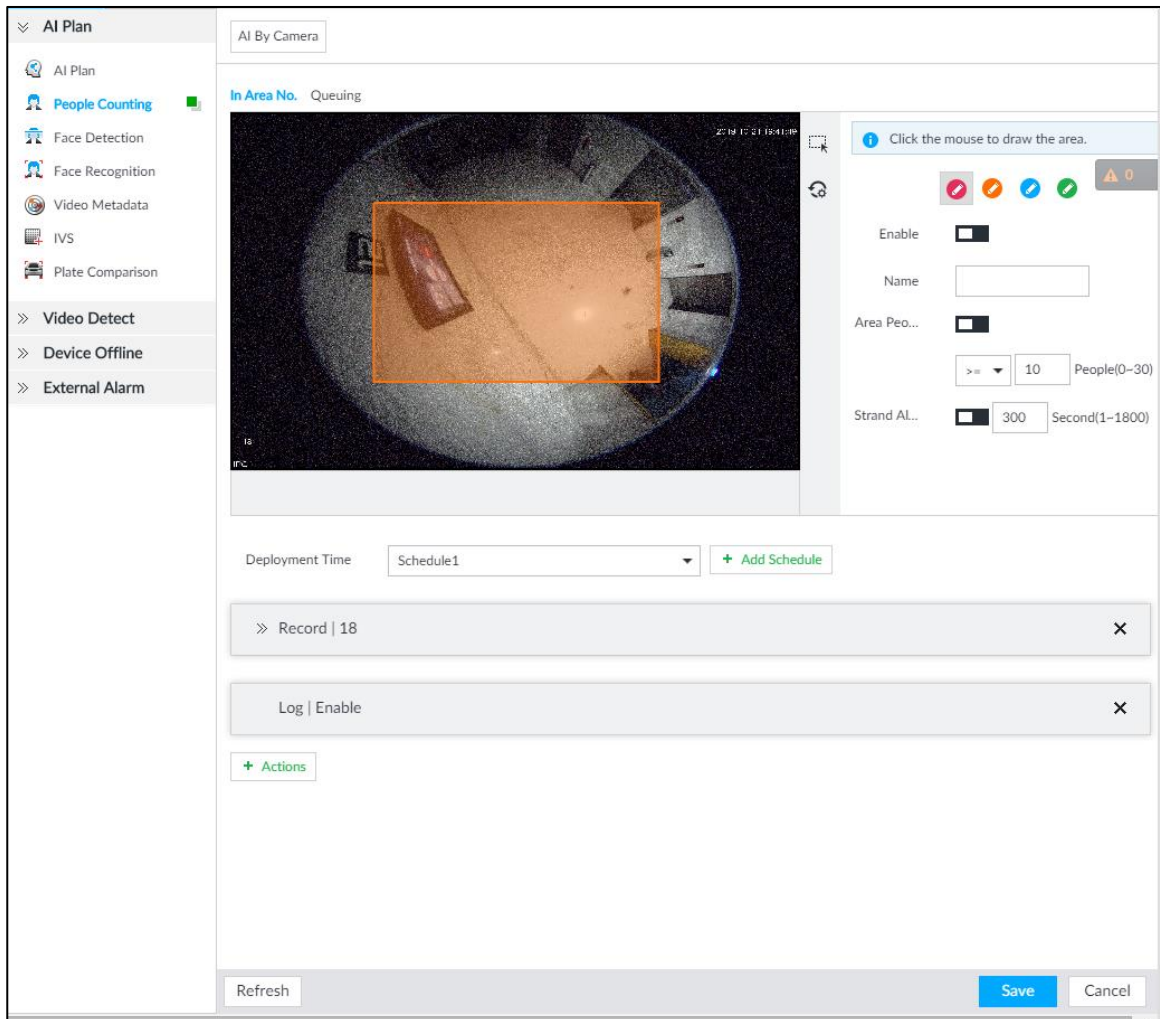
Step 1 Click , click , and then select **EVENT**.

The **EVENT** interface is displayed.


Step 2 Select a camera in the device tree, and then select **AI Plan > People Counting > In Area No.**







The **In Area No.** interface is displayed. See Figure 6-53.

Figure 6-53 In Area No.



Step 3 Draw a people counting area.




- 1) Click  to draw the first detection area.

Click    to draw more areas. You can draw 4 areas at most.
- 2) Click  to edit the area.
 - ◇ Click and drag  to adjust the position and length.
 - ◇ Click the white dot on the frame of the area to add turning corners.
 - ◇ Click  to restore to the default area.

Step 4 Set parameters. See Table 6-9.

Table 6-9 Parameters description of people counting

Parameters	Description
Enable	Click <input type="checkbox"/> to enable the selected area.
Name	Enter area name
Area People Counting	1. Click <input type="checkbox"/> to enable the alarm.

Parameters	Description
Alarm	<p>2. Set people number threshold.</p> <ul style="list-style-type: none"> • Select , and enter a threshold value. When the people number in the area is greater than the threshold, an alarm will be triggered. • Select , and enter a threshold value. When the people number in the area is smaller than the threshold, an alarm will be triggered.
Strand Alarm	<p>1. Click  to enable the alarm.</p> <p>2. Set time threshold for the alarm. When the dwell time of any person in the area is greater than the threshold, an alarm will be triggered.</p>

Step 5 Select a schedule in the **Deployment Time** drop-down list.

Alarms are triggered only within the scheduled time.

Step 6 Click **Actions** to set alarm linkage actions. For details, see "8.4.1 Alarm Actions."

Step 7 Click **Save**.

6.4.3 Queuing Detection

The system counts the number of people queuing in the detection area. When the number of people exceeds the threshold or the queue time is longer than the pre-defined time, an alarm is triggered.

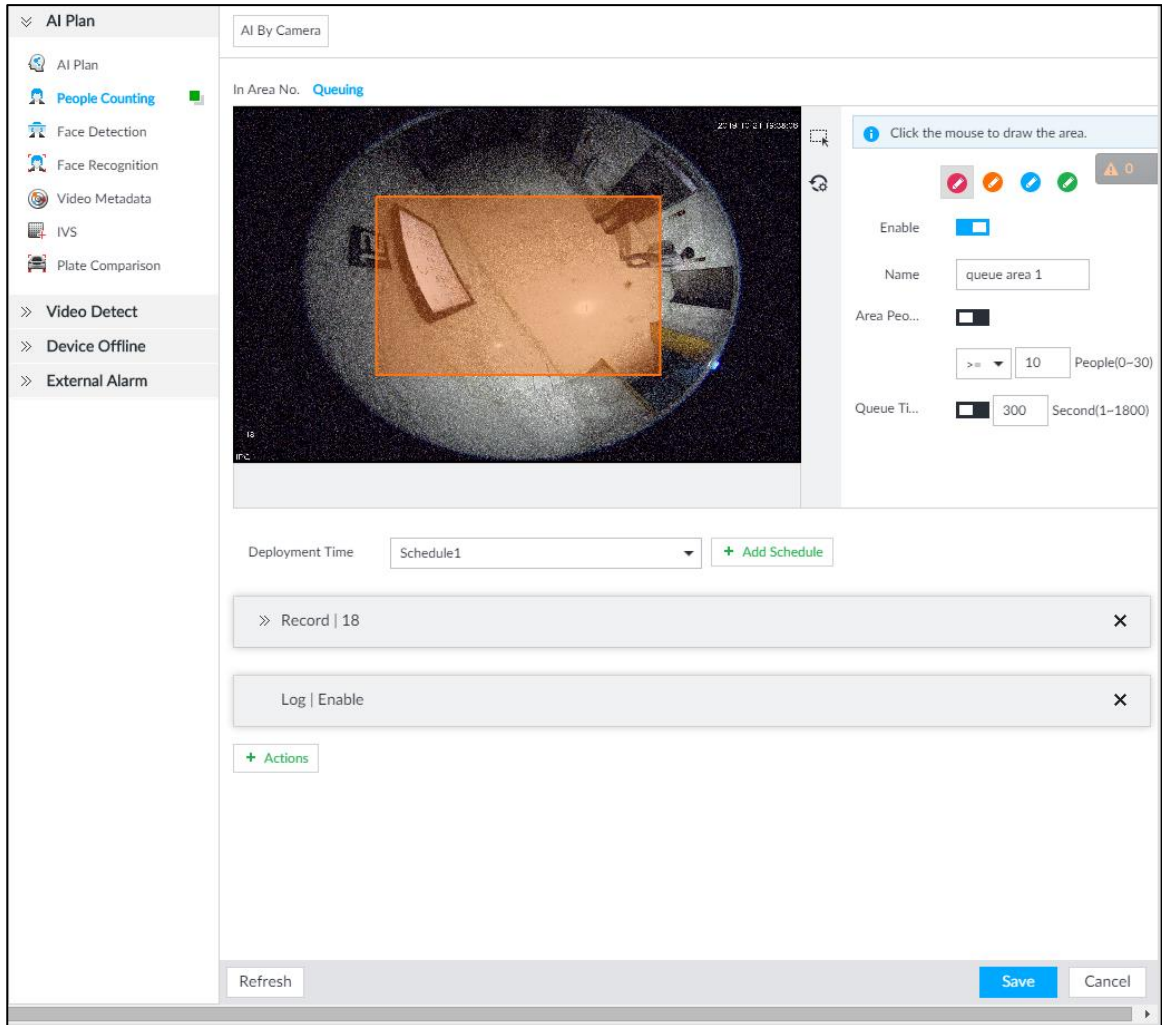
Step 1 Click , click , and then select **EVENT**.

The **EVENT** interface is displayed.


Step 2 Select a camera in the device tree, and then select **AI Plan > People Counting > Queuing**.







The **Queuing** interface is displayed. See Figure 6-54.

Figure 6-54 Queuing



Step 3 Draw a queuing detection area.

- 1) Click  to draw the first detection area.

 Click    to draw more areas. You can draw 4 areas at most.
- 2) Click  to edit the area.
 - ◇ Click and drag  to adjust the position and length.
 - ◇ Click the white dot on the frame of the area to add turning corners.
 - ◇ Click  to restore to the default area.

Step 4 Set parameters. See Table 6-10.

Table 6-10 Parameters description of queuing detection

Parameters	Description
Enable	Click <input type="checkbox"/> to enable the selected area.
Name	Enter the area name
Area People Counting Alarm	<ol style="list-style-type: none"> 1. Click <input type="checkbox"/> to enable the alarm. 2. Set people number threshold. <ul style="list-style-type: none"> • Select <input type="text" value="10"/>, and enter a threshold value. When the people number in the area is greater than the

Parameters	Description
	<p>threshold, an alarm will be triggered.</p> <ul style="list-style-type: none"> Select <input type="text"/> , and enter a threshold value. When the people number in the area is smaller than the threshold, an alarm will be triggered.
Queuing Time Alarm	<ol style="list-style-type: none"> Click <input type="checkbox"/> to enable the alarm. Set time threshold for the alarm. When the queuing time of any person in the area is longer than the threshold, an alarm will be triggered.

Step 5 Select a schedule in the **Deployment Time** drop-down list.

Alarms are triggered only within the scheduled time.

Step 6 Click **Actions** to set alarm linkage actions. For details, see "8.4.1 Alarm Actions."

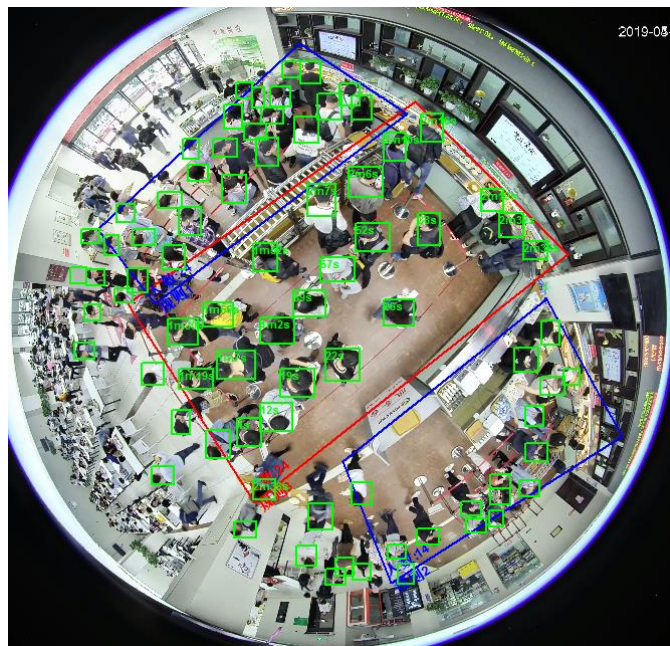
Step 7 Click **Save**.

6.4.4 Live View

On the **LIVE** interface, enable a view window that contains people counting video.

The live video which shows real-time people number and queuing time is displayed. See Figure 6-55.

Figure 6-55 Live view



The live video displays real-time people number in the region, and the region frame flashes red once there is an alarm. The queue-detection live view also shows head frames and the dwell time of each person.

6.5 Video Metadata

The system analyzes real-time video stream to detect the existence of 4 target types: human, human face, motor vehicle, non-motor vehicle. Once a target is detected, the system can record video, take snapshots and trigger alarms.

This section introduces how to configure the video metadata feature from enabling it and selecting target types to setting the live view of video metadata.

6.5.1 Enabling AI Plan

Enable AI plan when AI by camera is used. See "6.2.1 Enabling AI Plan" to enable AI detect function.

6.5.2 Configuring Video Metadata

After enabling video metadata, IVSS links the current remote device to take snapshots and record video when alarm is triggered.



- The Device supports metadata by camera (AI by Camera on the interface) or by the Device (AI by Device on the interface). This section takes metadata by the Device for example to introduce the configuration procedure.
- Video metadata cannot be enabled at the same time with face detection and IVS, because it conflicts with the two functions.

Step 1 Click  or , and then select **EVENT**.

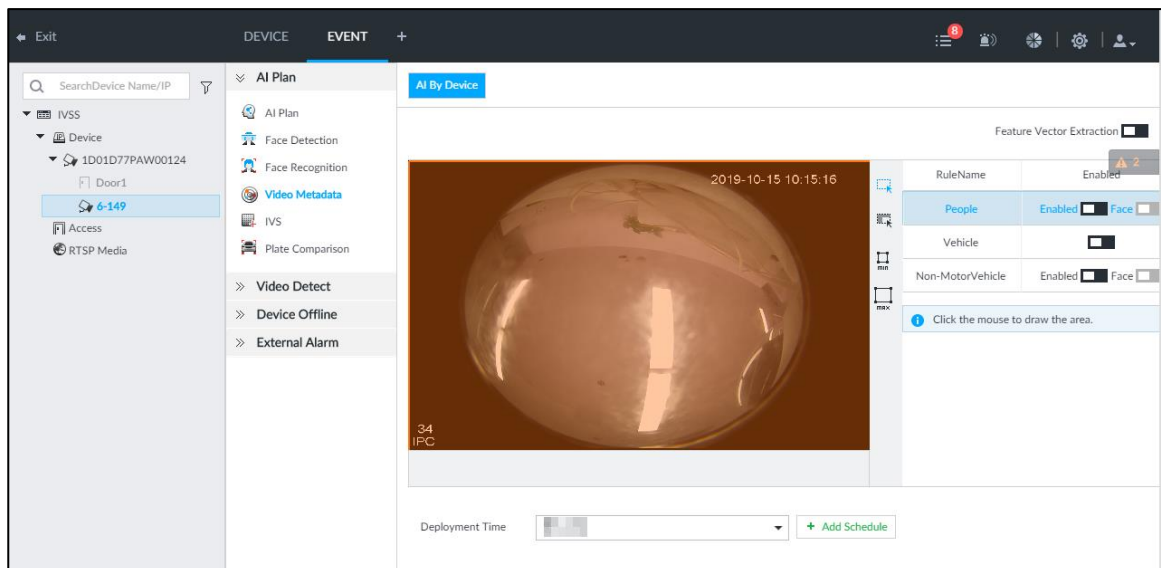
The **EVENT** interface is displayed.


Step 2 Select a device from the device tree at the left side.

Step 3 Select **AI Plan > Video Metadata > AI by Device**.


The **AI by Device** interface is displayed. See Figure 6-56.

Figure 6-56 AI by device





Step 4 Click  next to **Feature Vector Extraction** to enable feature extraction, and then the Device can extract features of human, vehicles and non-motor vehicles and display them on the live view. The search by image function is available only when feature vector extraction is enabled.

Step 5 Select the detection target.

- People: Click  next to **Enabled** to enable people detection. Face detection

can also be enabled at the same time.

- Vehicle: Click corresponding to enable vehicle detection.
- Non-Motor Vehicle: Click corresponding to enable non-motor vehicle detection.

Step 6 Click  (the icon changes to ) , and then you can configure detection area (orange) in the video image. See Figure 6-57.







- Click any white dot on the frame, and the dot changes to .
- Drag  to adjust the detection area.
- Click  to draw an excluded area which will not be detected. IVSS does not detect target within the excluded area.
 - ◇ Up to 4 excluded areas can be drawn.
 - ◇ To delete an excluded area, select the area, and then click .
- Click  or  to set the minimum size or maximum size of the face detection area. System triggers an alarm once the size of detected target is between the maximum size and the minimum size.

Figure 6-57 Detection area



Step 7 Click **Deployment Time** drop-down list to select schedule.

IVSS links alarm event when an alarm is triggered within the schedule configured.

- Click **Add Schedule** to add new schedule if no schedule is added or the existing schedule does not meet requirements. For details, see "8.8.4 Schedule."
- Click **View Schedule** to view details of schedule.

Step 8 Click **Save**.

6.5.3 Live View of Video Metadata

View the detection results of face, people, motor vehicle and non-motor vehicle on the **LIVE** interface.


6.5.3.1 Setting AI Display

Set the filtering conditions to display AI detection results.



Create view(s) before setting filtering conditions. To create a view, see "7.1.1 View Management."

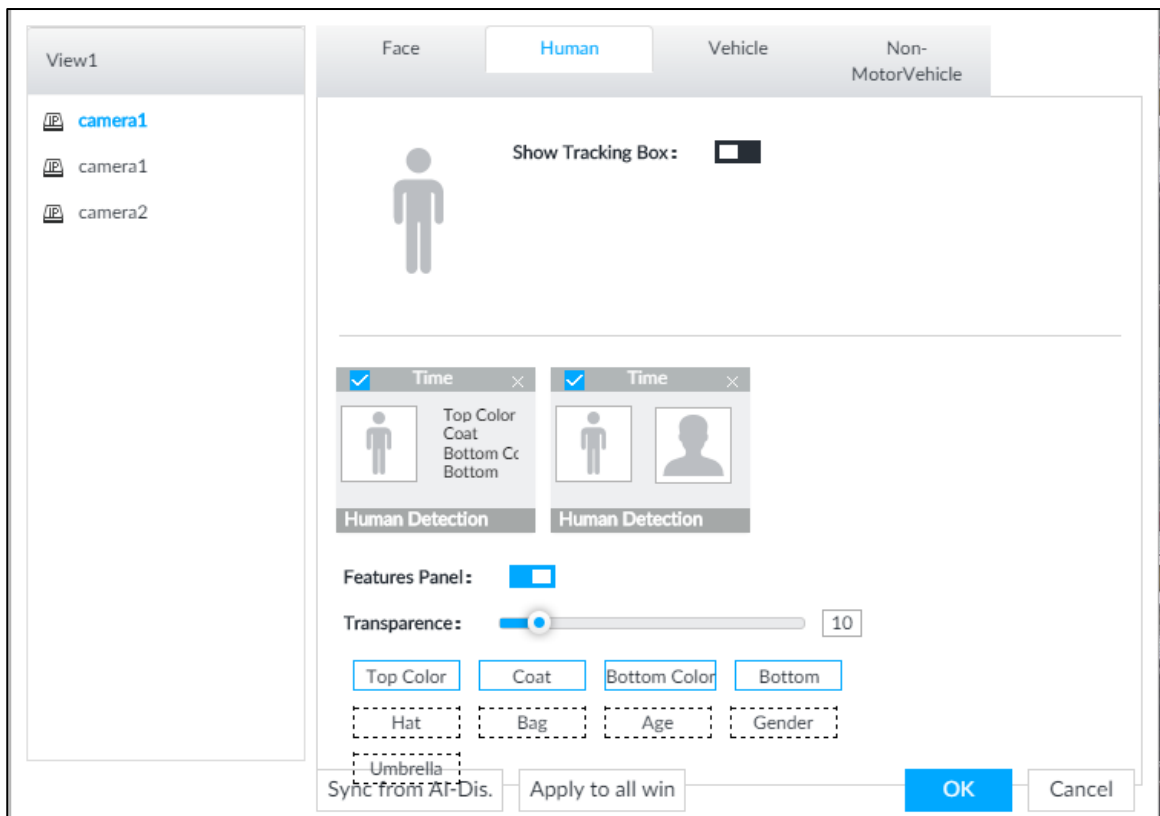
Step 1 Select a view from **LIVE > View > View Group**.


Step 2 Click  at the lower side of the **LIVE** interface, and then select **Face**, **Human**, **Vehicle** or **Non-Motor Vehicle**. See Figure 6-58.



The figure takes **Human** for example. The interface is for reference only, and the actual interface shall prevail.

Figure 6-58 Human




Step 3 Click  next to **Show Tracking Box**, and then a tracking box is displayed in the video when target that meets the filtering conditions is detected.

Step 4 Configure feature panel.

1) Click  next to **Features Panel** to enable feature panel.

A features panel is displayed on the right side of the video when target that meets the conditions is detected.

- 2) Click to select the panel type, for example, the **Human Detection** tab.
- 3) (Optional) Drag  to adjust the transparency of panel. The higher the value, the more transparent the panel.
- 4) (Optional) Select the features to be displayed in the panel.
 - Up to 4 features can be displayed.
 - 4 features are selected by default. To select another feature, click the selected feature to cancel it, and then click the feature to be displayed.

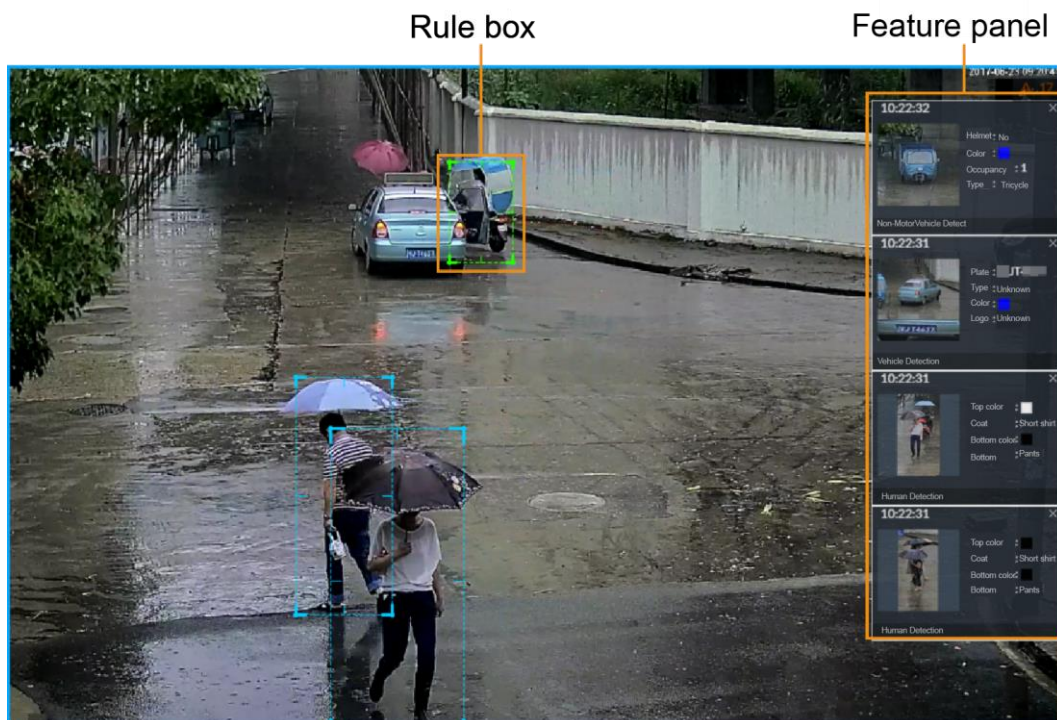
Step 5 Click **OK**.

6.5.3.2 Live View

On the **LIVE** interface, select a view from **View Group**, and the video image of the view will be displayed. See Figure 6-59.

- Rule box is displayed in real-time in the video image. Different detection targets correspond to different colors of rule box, and the actual interface shall prevail.
- Features panels are displayed on the right side of the video image.

Figure 6-59 Live



Point to the features panel, and the icons are displayed. See Figure 6-60.

Figure 6-60 Icons (vehicle detection)



- Click to add plate information to plate database.
- Click , or double-click the detected image to play back the video record (10 s before and after the snapshot).
- Click to search for similar targets in the history videos.

6.5.3.3 Detection Statistics

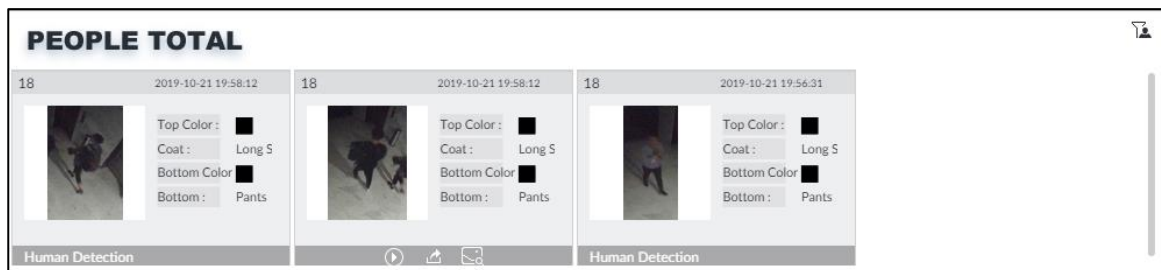
View the detection statistics of human, motor vehicle and non-motor vehicle.

6.5.3.3.1 Human

On the **LIVE** interface, click , the **PEOPLE TOTAL** interface is displayed.

Click , and then select **Snap With Face** and **Snap Without Face**. The information of detected human and face is displayed. See Figure 6-61.

Figure 6-61 Human detection




- Point to the snapshot, and then click to add the face image to face database. For details, see "6.3.3.2.3 Adding from Detection Snapshots."



This function is available when face image is captured.

- Point to the snapshot, and then click or double-click a pted picture to play back the video record (10 s before and after the snapshot).
- Point to the snapshot, and then click to export the video record to specified saving path.

- Point to the snapshot, and then click  to search for similar targets in the snapshot records.



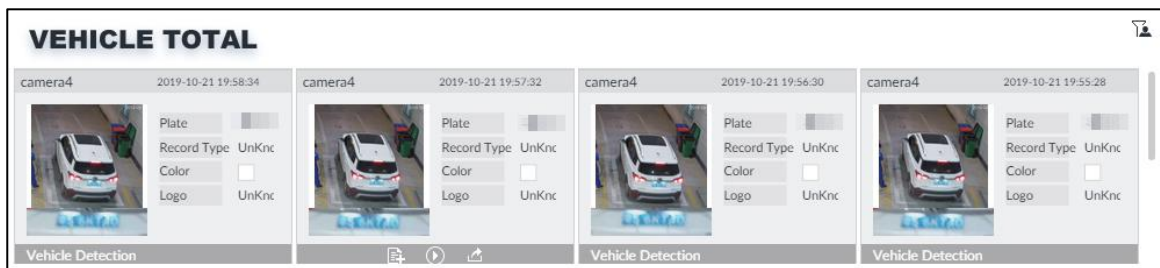
Make sure that USB storage device is connected during local operation.




6.5.3.3.2 Motor Vehicle

On the **LIVE** interface, click , the **VEHICLE TOTAL** interface is displayed.

Click , and then select **Vehicle Recognition**, the information of detected vehicles is displayed. See Figure 6-62.

Figure 6-62 Motor vehicle detection



- Move the mouse pointer to the panel, and then click  to add the license plate image to plate database. For details, see "6.8.3.2.3 Adding from Detection Results."
- Move the mouse pointer to the panel, and then click , or double-click detected picture to play back the video record (10 s before and after the snapshot).
- Move the mouse pointer to the panel, and then click  to export the video record to specified saving path.



Make sure that USB storage device is connected during local operation.

6.5.3.3.3 Non-motor Vehicle

On the **LIVE** interface, click , the **NONMOTOR TOTAL** interface is displayed.


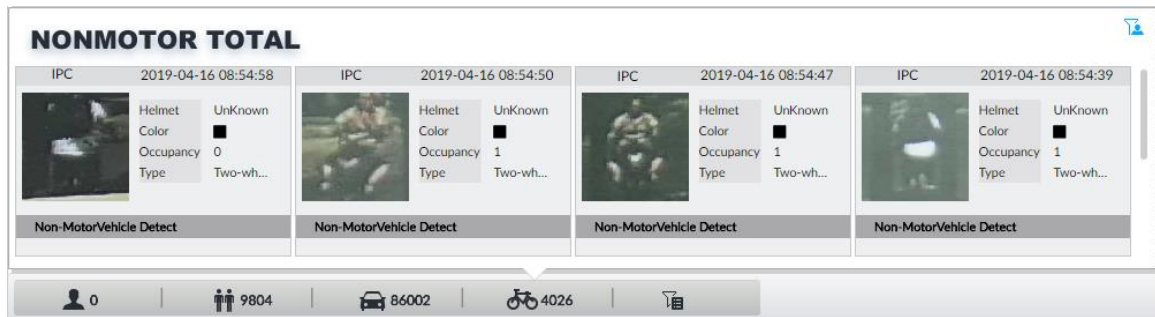


Click , and then select **Snap With Face** and **Snap Without Face**. The information of detected non-motor vehicles is displayed. See Figure 6-63.


Figure 6-63 Non-motor vehicle detection



- Move the mouse pointer to the detected information, and then click , or double-click detected picture to play back the video record (10 s before and after the snapshot).
- Move the mouse pointer to the detected information, and then click  to export the video record to specified saving path.



Make sure that USB storage device is inserted during local operation.

- Point to the snapshot, and then click  to search for similar targets in the snapshot records.



 appears on the panel of the non-motor vehicle snapshot that contains a human face.


6.5.4 AI Search

Select device and set properties to search for detection results.

6.5.4.1 Human Search

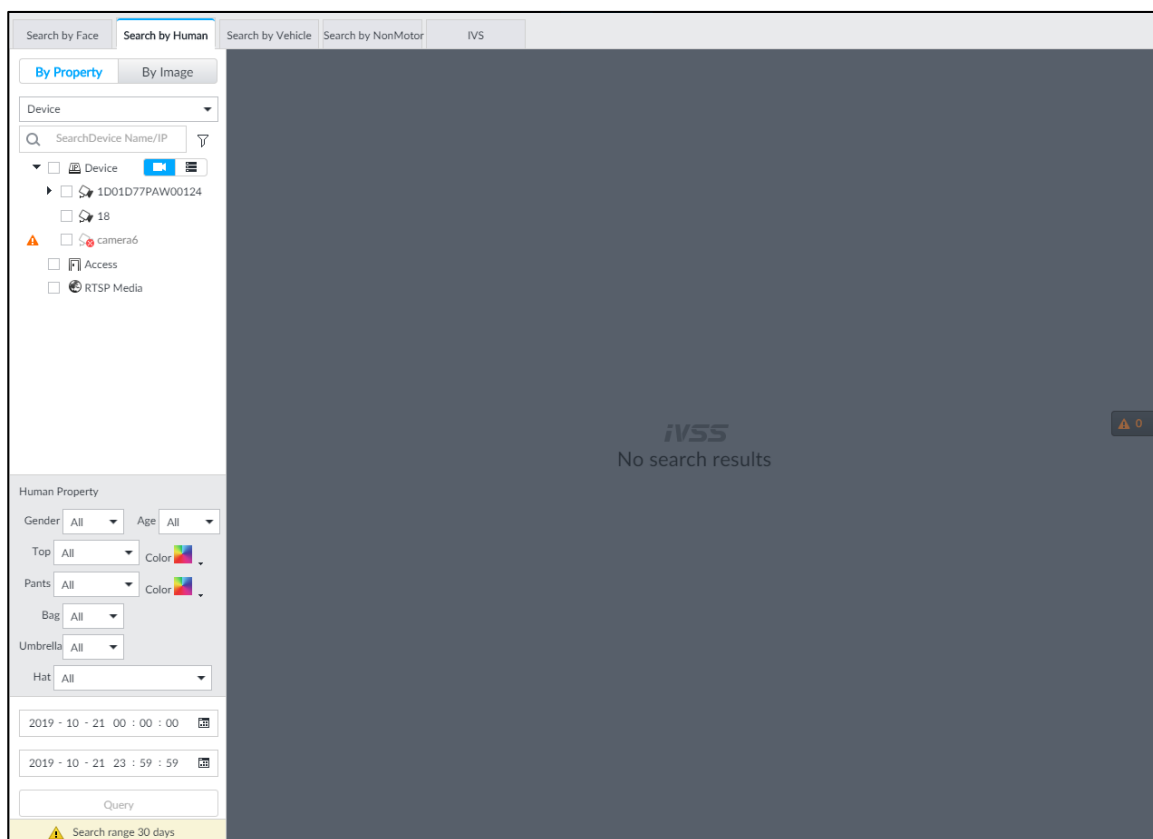
Select device and set human properties to search human detection results.

6.5.4.1.1 Searching by Property

Step 1 On the **LIVE** interface, click , and then select **AI SEARCH > Search by Human**.

The **Search by Human** interface is displayed. See Figure 6-64.

Figure 6-64 Search by human



Step 2 Select a device, and then set human properties and time period.

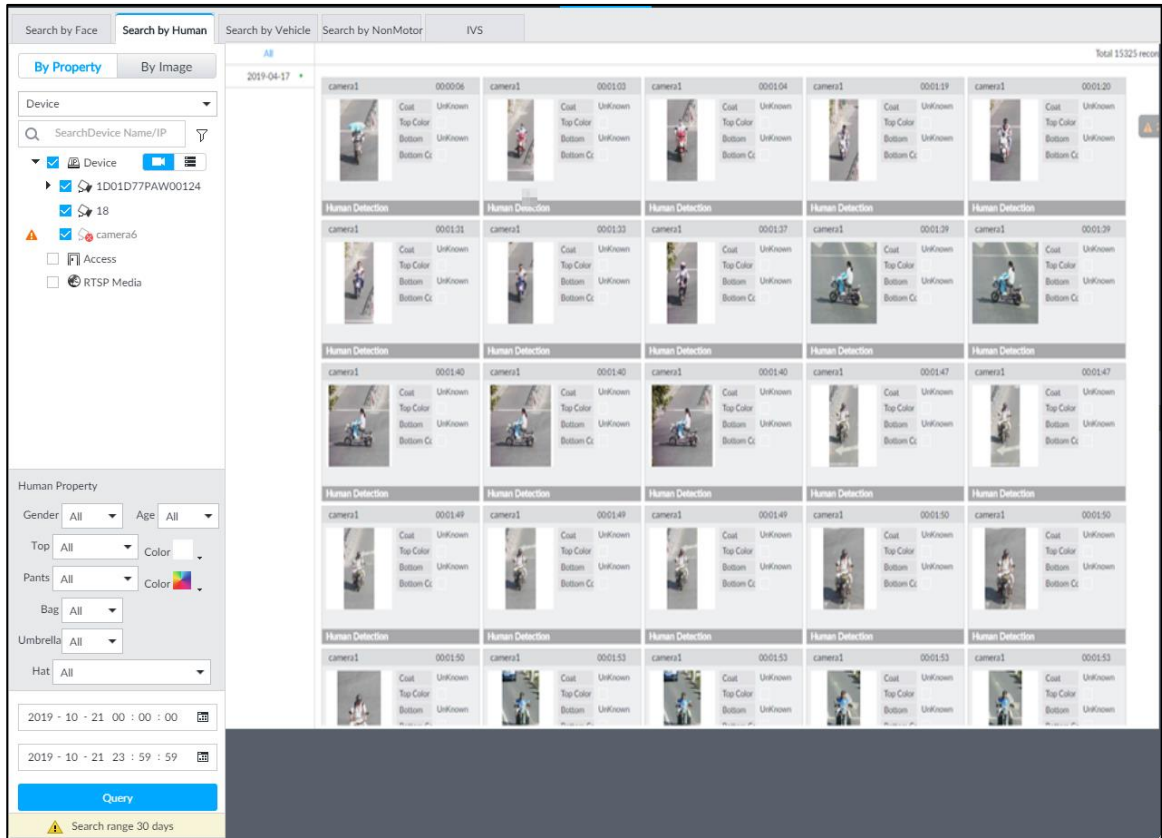
Click  or  to set the color.  means more than one color.

Step 3 Click **Query**.

The search result is displayed. See Figure 6-65.

- If face is captured, the human and face snapshots are displayed.
- If no face is captured, the human snapshot and human properties are displayed.

Figure 6-65 Search result



Other Operations

Click on one displayed panel, and the icons are displayed. See Figure 6-66 or Figure 6-67. For details, see Table 6-11.

Figure 6-66 Icons (1)

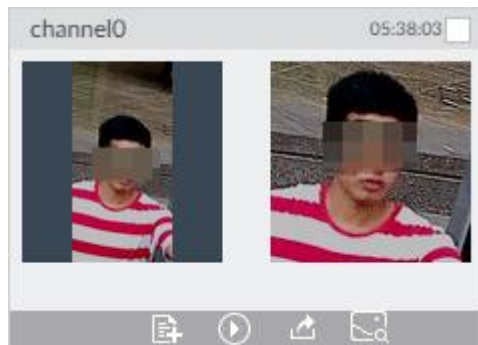


Figure 6-67 Icons (2)

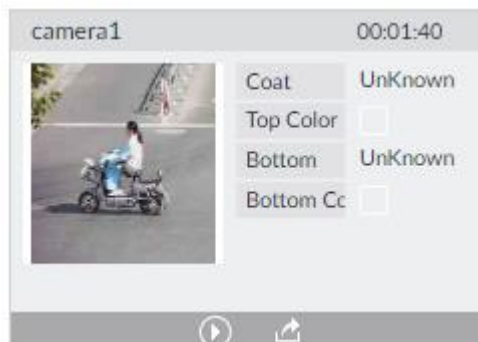















Table 6-11 Operation

Icon	Operation
	<ul style="list-style-type: none"> Select one by one: Click  to select the panel.  means the panel is selected. Select in batches: Select All to select all the panels on the interface.
	Click  or double-click the panel to play back the video record (10 s before and after the snapshot).
	Click  to add picture to database. See "6.3.3.2.3 Adding from Detection Snapshots."
	<ul style="list-style-type: none"> Export one by one: Click  to export picture, video and excel. For details, see "6.2.4.3 Exporting Face Records." Export in batches: Select the panel and click  to export picture, video and video player. For details, see "6.2.4.3 Exporting Face Records." <p> After setting alarm linkage snapshot, during exporting images, the system exports detected images and panoramic images at the time of snapshot.</p>
	Click  to search for similar targets in the snapshot records.

6.5.4.1.2 Searching by Image


Upload human body pictures to search for similar targets.



The search by image function is only available when feature vector extraction is enabled. For details, see Step 4 in "6.5.2 Configuring Video Metadata."

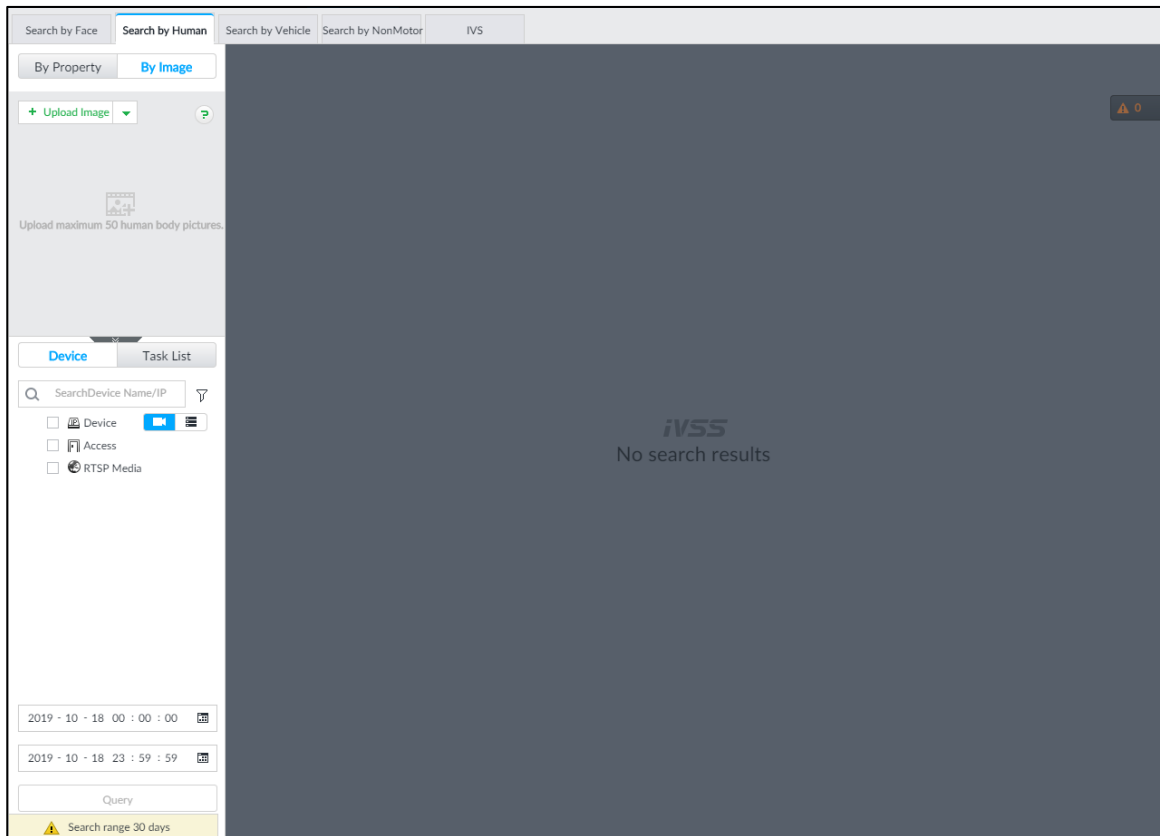
Searching Devices

Upload human body pictures to search the specific devices for similar targets.

Step 1 On the **LIVE** interface, click , and then select **AI SEARCH > Search by Human > By Image**.

The **By Image** interface is displayed. See Figure 6-68.

Figure 6-68 Search by image




Step 2 Click the **Device** tab.

Step 3 Upload a picture.

Upload from PC or USB storage device.



Up to 50 pictures can be uploaded. Up to 10 pictures can be uploaded at a once.

- 1) Point to **+ Upload Image** , and then select **Local**.
- 2) Select one or more pictures.
- 3) Click **OK**.

After the upload is completed, the uploaded picture is shown at the upper-left corner of the interface. The latest 10 pictures are displayed by default.



Up to 10 pictures can be selected at the same time.

Step 4 Set similarity. It is 80% by default.


Step 5 Select a remote device in the device list, and then set search time.

Step 6 Click **Query**.

The results are displayed.

Searching Task List

Upload a human body picture search the analyzed video for similar targets. For details about AI tasks, see "9.2 Task Management."

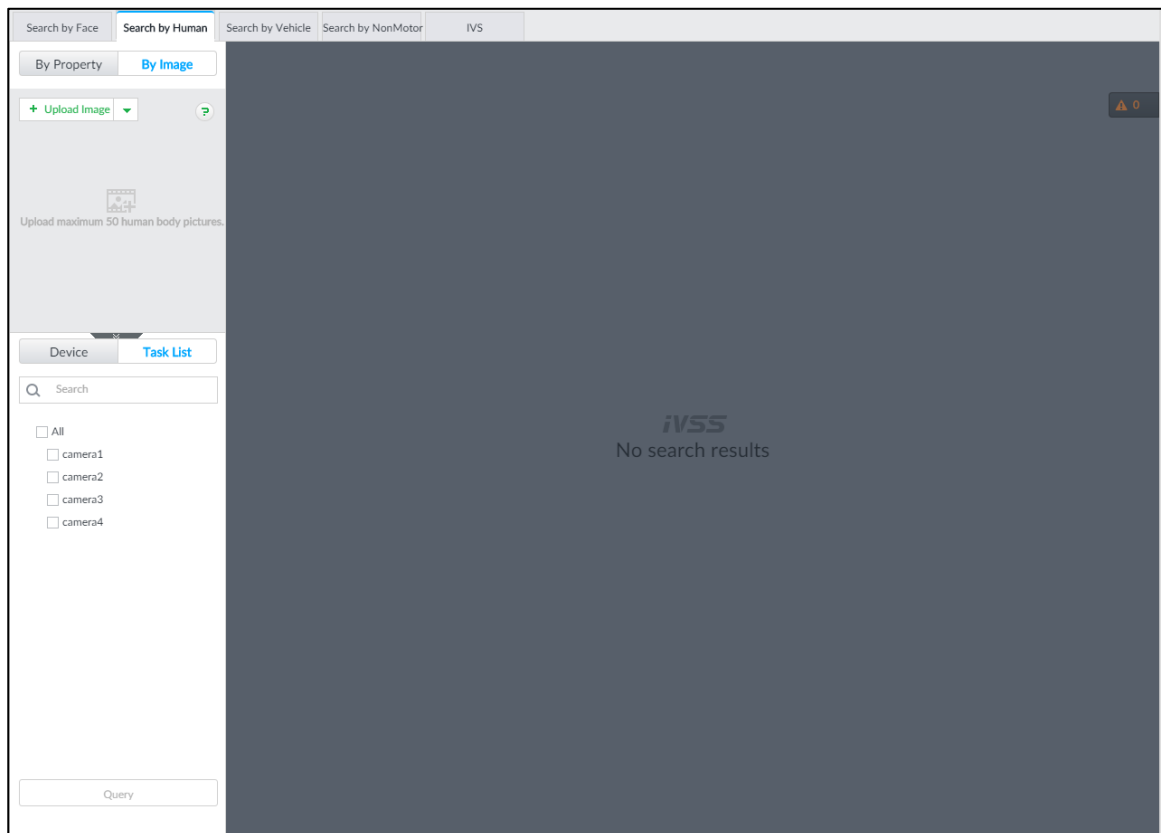
Step 1 On the **LIVE** interface, click , and then select **AI SEARCH > Search by Human > By Image**.

Step 2 The **By Image** interface is displayed.

Step 3 Click **Task List**.

The **Task List** interface is displayed. See Figure 6-69.

Figure 6-69 Task list



Step 4 Upload a human body picture. For details, see step 3 in "6.2.4.2.1 Searching Devices."

Step 5 Set similarity. It is 80% by default.

Step 6 Select a task to be searched.

Step 7 Click **Query**.

The results are displayed.

6.5.4.2 Vehicle Search

Set event type and vehicle properties to search vehicle detection results.

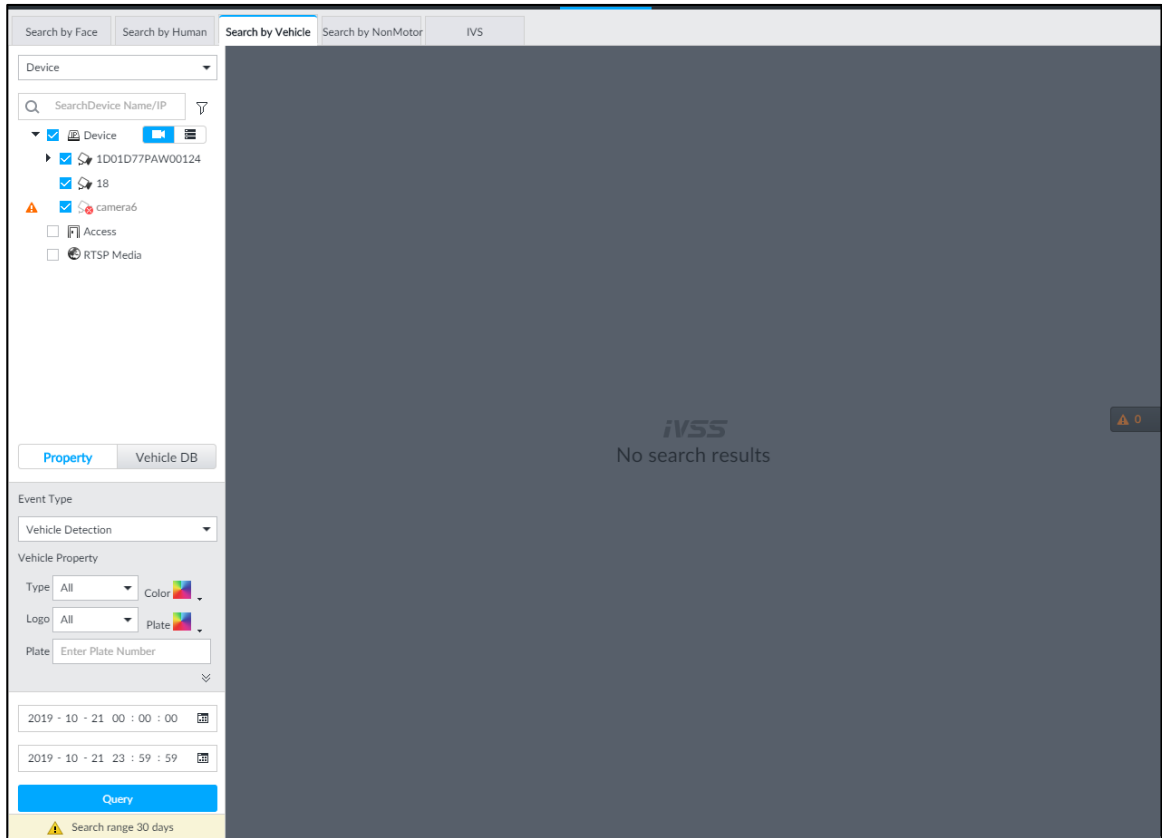
Step 1 On the **LIVE** interface, click **+**, and then select **AI SEARCH > Search by Vehicle**.

The **Search by Vehicle** interface is displayed.

Step 2 Select device, and then click **Property** tab.

The **Property** interface is displayed. See Figure 6-70.

Figure 6-70 Property



Step 3 Select **Vehicle Detection** as **Event Type**.

Step 4 Set vehicle properties and time period.

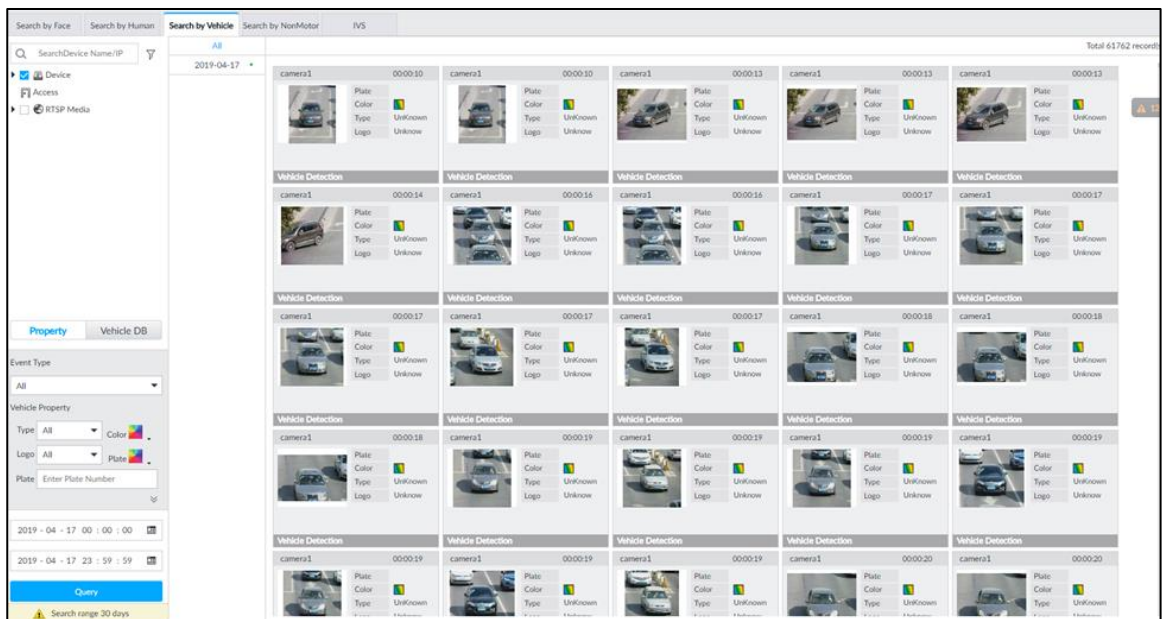
Click  or  to set the color.  means more than one color.

Step 5 Click **Query**.

The search results are displayed. See Figure 6-71.

If license plate is detected, both the scenario and the license plate will be displayed.

Figure 6-71 Search result



Click one displayed panel, and the icons are displayed. See Figure 6-72 and Table 6-12.

Figure 6-72 Icons

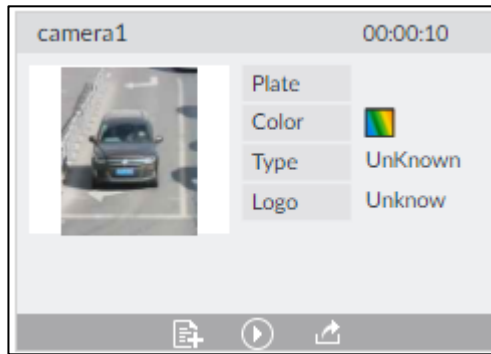


Table 6-12 Operation

Icon	Operation
	<ul style="list-style-type: none"> Select one by one: Click <input type="checkbox"/> to select the panel. <input checked="" type="checkbox"/> means the panel is selected. Select in batches: Select All to select all the panels on the interface.
	Click or double-click the panel to play back the video record (10 s before and after the snapshot).
	Click to add picture to database. See "6.3.3.2.3 Adding from Detection Snapshots."
	<ul style="list-style-type: none"> Export one by one: Click to export picture, video and excel. For details, see "6.2.4.3 Exporting Face Records." Export in batches: Select the panel and click to export picture, video and video player. For details, see "6.2.4.3 Exporting Face Records." <p></p> <p>After setting alarm linkage snapshot, during exporting images, the system exports detected images and panoramic images at the time of snapshot.</p>

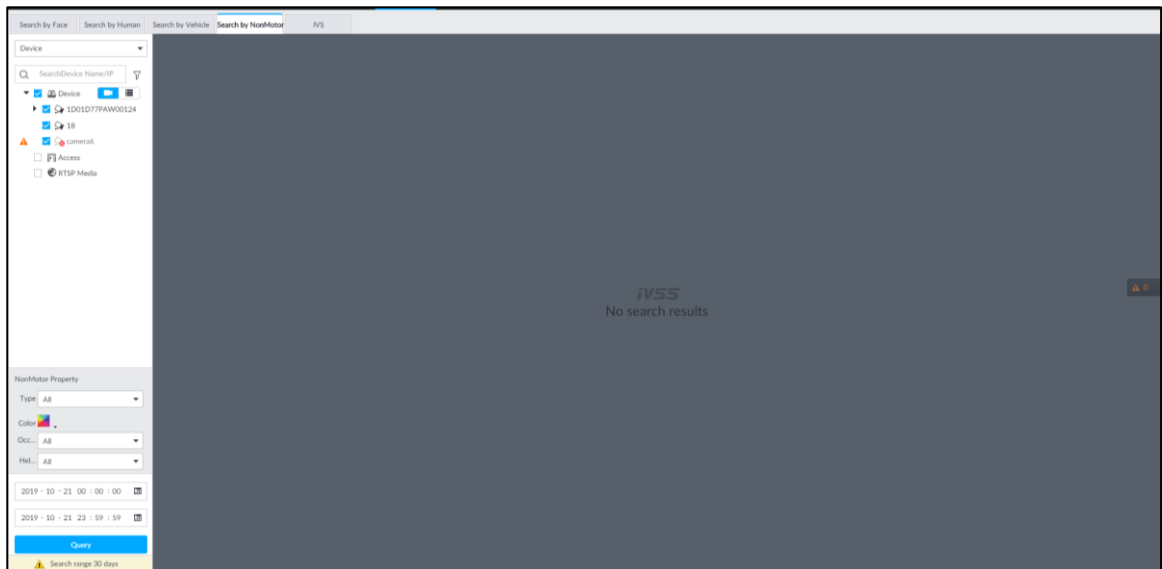
6.5.4.3 Non-motor Vehicle Search

Set event type and non-motor vehicle properties to search non-motor vehicle detection results.

Step 1 On the **LIVE** interface, click , and then select **AI SEARCH > Search by NonMotor**.

The **Search by NonMotor** interface is displayed. See Figure 6-73.

Figure 6-73 Search by non-motor vehicle



Step 2 Select the device you want to search.

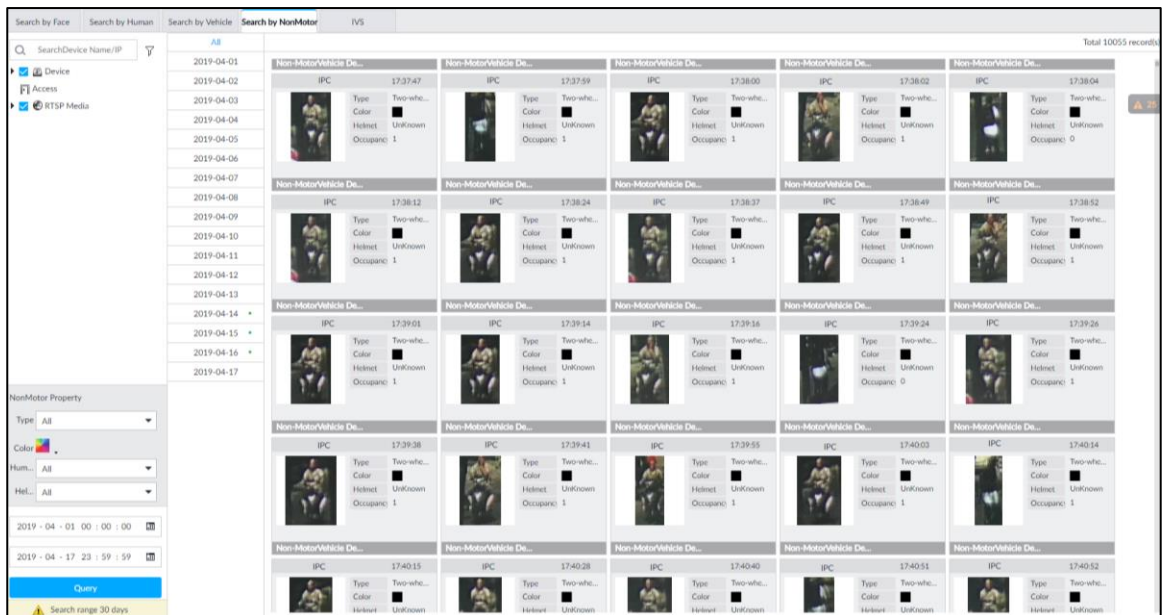
Step 3 Set non-motor vehicle properties and time period.

Click  or  to set the color.  means more than one color.

Step 4 Click **Query**.

The search results are displayed. See Figure 6-74.

Figure 6-74 Search results



Click on one displayed panel, and the icons are displayed. See Figure 6-75 and Table 6-13.

Figure 6-75 Icons

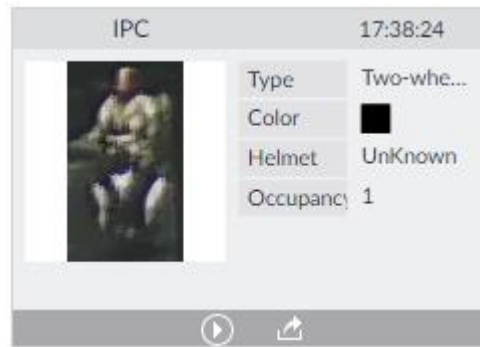


Table 6-13 Operation

Icon	Operation
	<ul style="list-style-type: none"> Select one by one: Click to select the panel. means the panel is selected. Select in batches: Select All to select all the panels on the interface.
	Click or double-click the panel to play back the video record (10 s before and after the snapshot).
	<ul style="list-style-type: none"> Export one by one: Click to export picture, video and excel. For details, see "6.2.4.3 Exporting Face Records." Export in batches: Select the panel and click to export picture, video and video player. For details, see "6.2.4.3 Exporting Face Records." <p></p> <p>After setting alarm linkage snapshot, during exporting images, the system exports detected images and panoramic images at the time of snapshot.</p>
	Click to search for similar targets in the snapshot records.

6.6 IVS

The IVS feature includes a number of behavior detections such as fence-crossing, intrusion, tripwire, parking, crowd gathering, missing object, abandoned object, and loitering. You can configure alarm notifications of those intelligent detections.

This section introduces how to configure the intelligent detections.



- For the same camera, IVS and face detection cannot be enabled at the same time.
- Some device models only support IVS by camera. The actual interface shall prevail.

6.6.1 Enabling AI Plan

Enable AI plan when AI by camera is used. See "6.2.1 Enabling AI Plan" to enable AI detect function.

6.6.2 Configuring IVS

Configure IVS rules. IVS functions are different between AI by camera and AI by device. For details, see Table 6-14.

- IVS functions with AI by camera: Fence-crossing, tripwire, intrusion, abandoned object, parking detection, people gathering, object removed, and loitering. Different cameras support different functions, and the actual interface shall prevail.
- IVS functions with AI by device: Tripwire, intrusion.

Table 6-14 IVS functions description

Functions	Description
Fence-crossing	Alarm is triggered when a target is crossing the pre-defined fence.
Tripwire	Alarm is triggered when a target is crossing the pre-defined tripwire.
Intrusion	Alarm is triggered when a target is entering, leaving, or appears in the detection area.
Abandoned Object	Alarm is triggered when an object is left in the detection area and the existence time is longer than the threshold.
Missing Object	Alarm is triggered when an object is removed from the detection area and not put back after the pre-defined time period.
Parking Detection	Alarm is triggered when a target remains still within a time period longer than the pre-defined time duration.
People Gathering	Alarm is triggered when people gathering is detected or people density is larger than the threshold.
Loitering	Alarm is triggered when a target keeps loitering in a time period longer than the threshold. Alarm will be triggered again if the target stays in the detection area after the first alarm.

Take tripwire as the example. The configuration procedure is as follows.

Step 1 Click , or click  on the configuration interface, and then select **EVENT**.

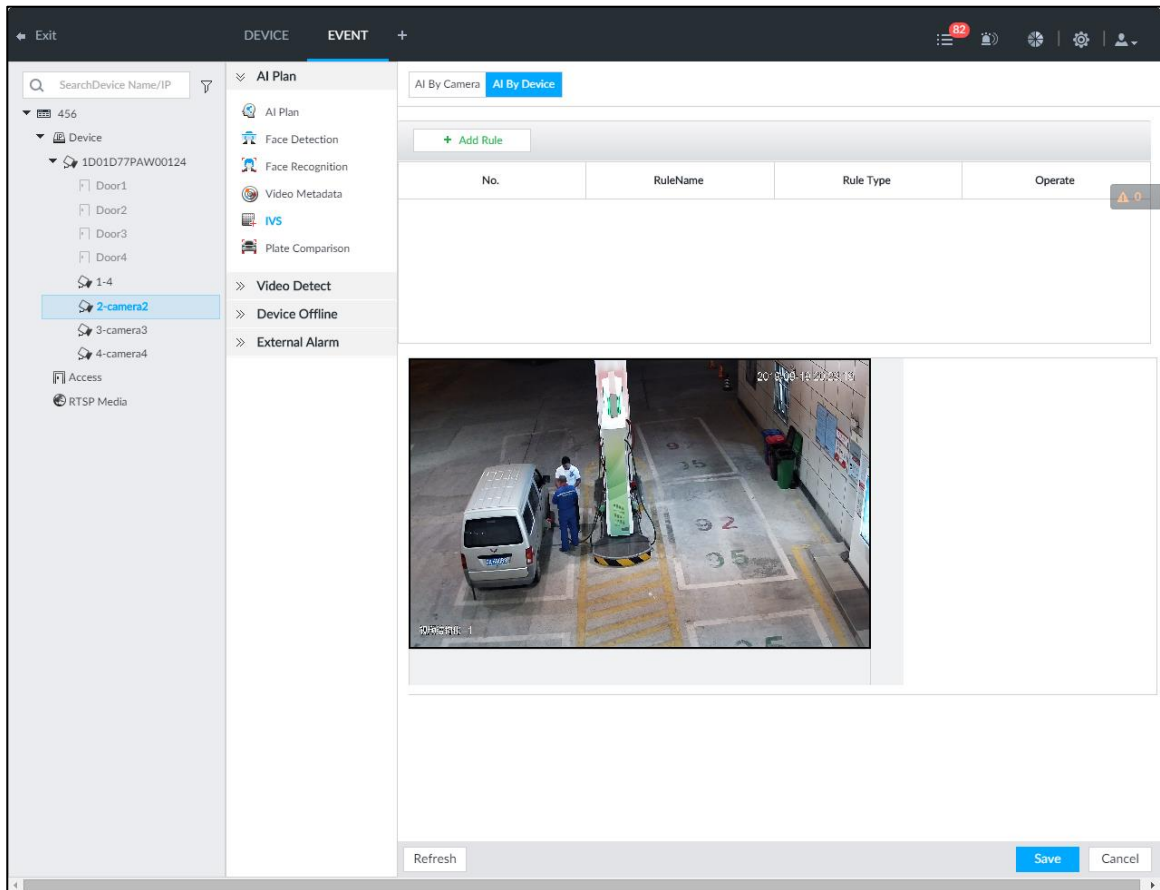
The **EVENT** interface is displayed.

Step 2 Select remote device in the device tree on the left.

Step 3 Select **AI Plan > IVS Rule**. Click **AI by Camera** or **AI by Device**.

The **Add Rule** interface is displayed. See Figure 6-76.

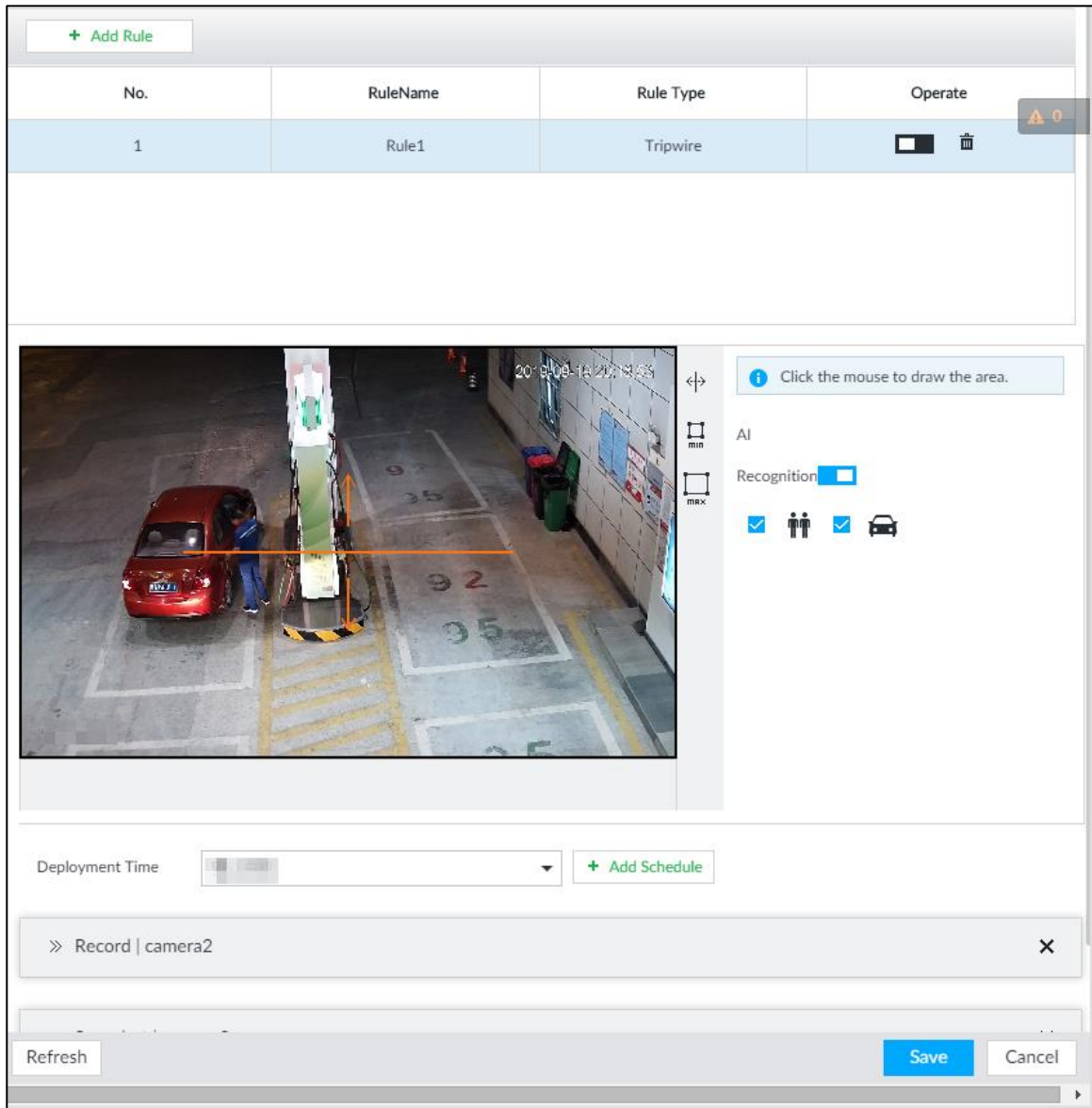
Figure 6-76 Add rules



Step 4 Set tripwire rules.

- 1) Click **Add Rule**, and then select **Tripwire**.
The rule information is displayed. See Figure 6-77.


Figure 6-77 Configuring tripwire detection rules



- 2) Click to enable detection rule.
 Click to delete detection rule.
- 3) Click to edit the tripwire line.
 - Drag to adjust position or length of the line.
 - Click or to set the directions. An alarm will be triggered only when the target crosses the line in the designated direction.
 - Click the white dot on the line to add a turning point. Drag at the turning point to adjust position or length.
- 4) Click or to set minimum size or maximum size of detection target.
 System triggers an alarm once the detected target size is between the maximum size and the minimum size.


Step 5 (Optional) For other requirements, see Table 6-15.

Table 6-15 IVS rules configuration requirements

Functions	Description
Fence-crossing	Draw 2 detection lines.  <ul style="list-style-type: none"> Transparent fences such as iron fence are not supported,. Extremely short walls (height lower than normal height) are not supported.
Tripwire	Draw 1 detection line.
Intrusion	Draw 1 detection line.
Abandoned Object	With the abandoned object detection, a person or vehicle that stays still for a long time will also trigger an alarm; if the object is smaller than human or vehicle, you can set the target size to filter out people and cars, or extend the minimum lasting duration to avoid false alarms caused by short dwell of people. For the crowd gathering detection, false alarms could happen due to low installation height, large proportion of human body size in the image, camera view blocking, continuous shaking of camera, shaking leaves, frequent door opening and closing, and dense traffic of vehicles and people.
Missing Object	
Parking Detection	
Crowd Gathering	
Loitering	

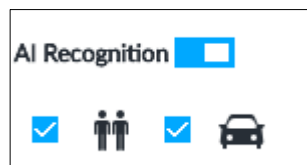
Step 6 AI Recognition

After setting AI recognition, when the system detects a person, vehicle or non-motor vehicle, a rule box will appear beside the target on the video.



- 1) Click  to enable AI recognition function.

The recognition type option is displayed. See Figure 6-78.

Figure 6-78 Type



- 2) Select a recognition type.

-  is to recognize human, and  is to recognize vehicle.
- After enabling AI recognition function, at least one recognition type shall be selected.

Step 7 Click **Deployment Time** to select schedule from the drop-down list.

After setting deployment period, system triggers corresponding operations when there is a motion detection alarm in the specified period.

- Click **View Schedule** to view detailed schedule settings.
- If the schedule is not added or the added schedule does not meet actual needs, click **Add Schedule**.

Step 8 Click **Actions** to set alarm action. See "8.4.1 Alarm Actions" for detailed information.



Repeat Step 4-Step 8 to add multiple detection rules. You can add max. 10 detection rules at the same time.

Step 9 Click **Save**.

6.6.3 Live View of IVS

On the **LIVE** interface, view real-time IVS results.

6.6.3.1 Setting AI Display

Set the display rules of detection results.



Make sure that view is created before setting AI display. To create view, see "7.1.1 View Management."

Step 1 Select a view from **LIVE > View > View Group**.


Step 2 Click , and then select the **Human** or **Vehicle** tab. See Figure 6-79 or Figure 6-80.

Figure 6-79 Human

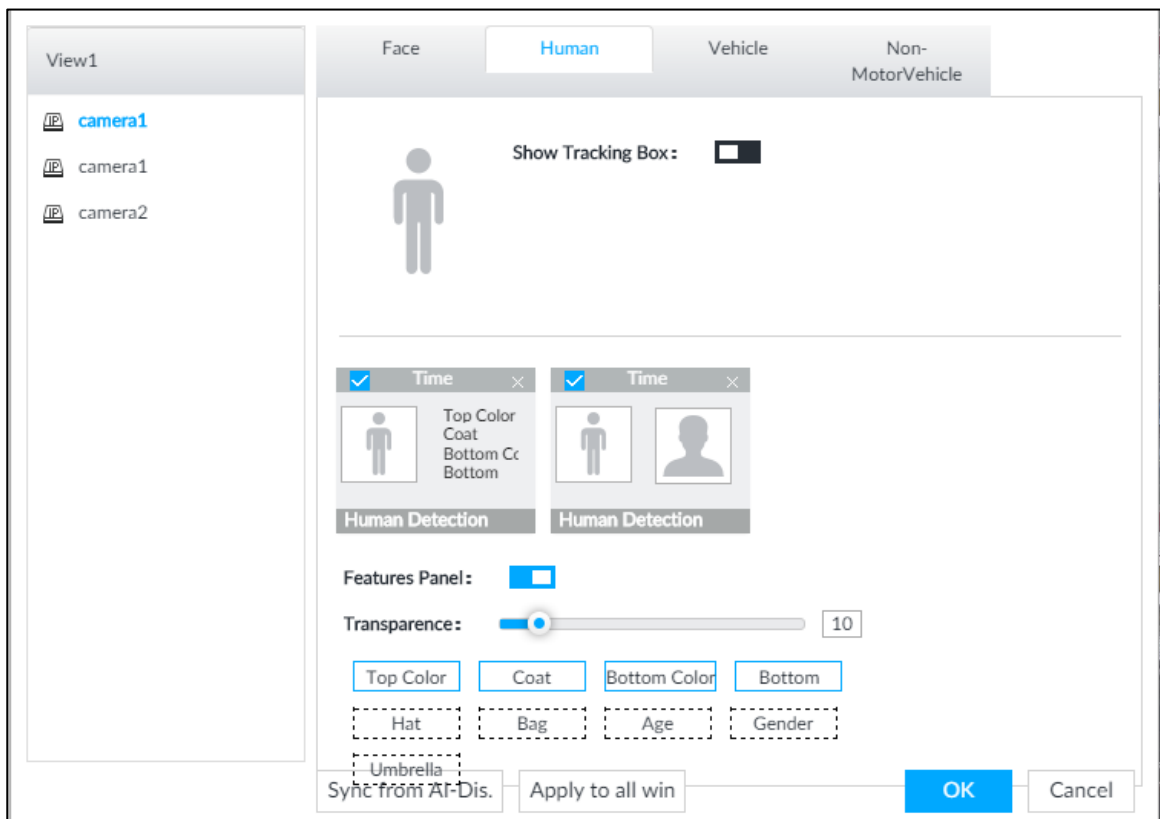
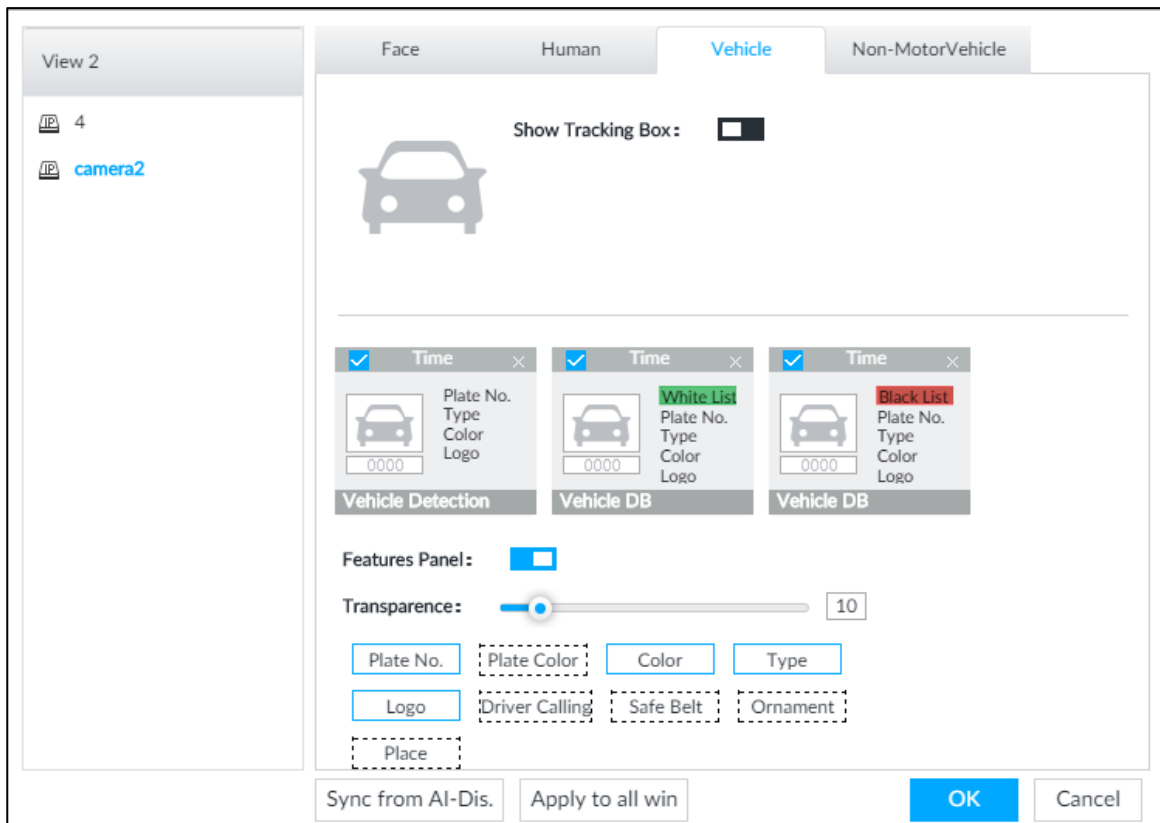



Figure 6-80 Vehicle



Step 3 Click next to **Show Tracking Box**.

Step 4 Configure feature panel.

- 1) Click next to **Features Panel** to enable feature panel.
A features panel is displayed on the right side of the video when a target that meets the conditions is detected.
- 2) Click to select the panel type, for example, the **Human Detection** tab.
- 3) (Optional) Drag  to adjust the transparency of panel. The higher the value, the more transparent the panel.
- 4) (Optional) Select the features to be displayed in the panel.
 - Up to 4 features can be displayed.
 - 4 features are selected by default. To select another feature, click the selected feature to cancel it, and then click the feature to be displayed.

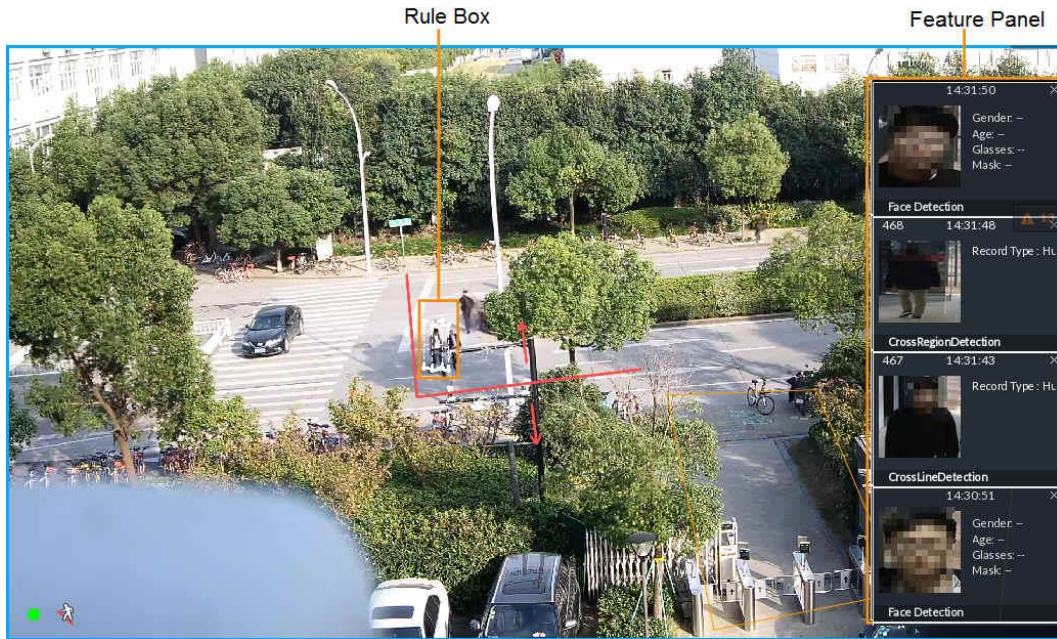
Step 5 Click **OK**.


6.6.3.2 Live View

Go to the **LIVE** interface, enable view, and then the Device displays view video. See Figure 6-81.

- When a target triggers cross line or cross region rule, the line or region frame in the view flickers in red.
- After setting AI recognition, when the system detects a person or vehicle, a rule frame will appear beside the person and vehicle in the view.
- There is a feature panel on the right side of the video window.

Figure 6-81 Live



Move the mouse pointer to features panel, and the operation icons are displayed. Click  or double-click the detected image, so the system starts to play back the recorded videos (10 s before and after the snapshot).

6.6.3.3 Detection Statistics



On the **LIVE** interface, click . The **PEOPLE TOTAL** interface is displayed. Click , and then select **IVS**. The people detection records are displayed. See Figure 6-82.

Figure 6-82 People total







Click . The **VEHICLE TOTAL** interface is displayed. Click , and then select **IVS**. The detected vehicles are displayed. See Figure 6-83.



Figure 6-83 Vehicle total





- Point to a picture and click , or double-click the picture, so the system starts playing back video (10 s before and after the snapshot moment).
- Point to a picture and click  to export video and picture.



Make sure that USB storage device is connected during local operation.

On the **LIVE** interface, click . The **NONMOTOR TOTAL** interface is displayed. Click , and then select **IVS**. The detected non-motor vehicles are displayed.

- Point to a picture and click , or double-click the picture, so the system starts playing back video (10 s before and after the snapshot moment).
- Point to a picture and click  to export video and picture.

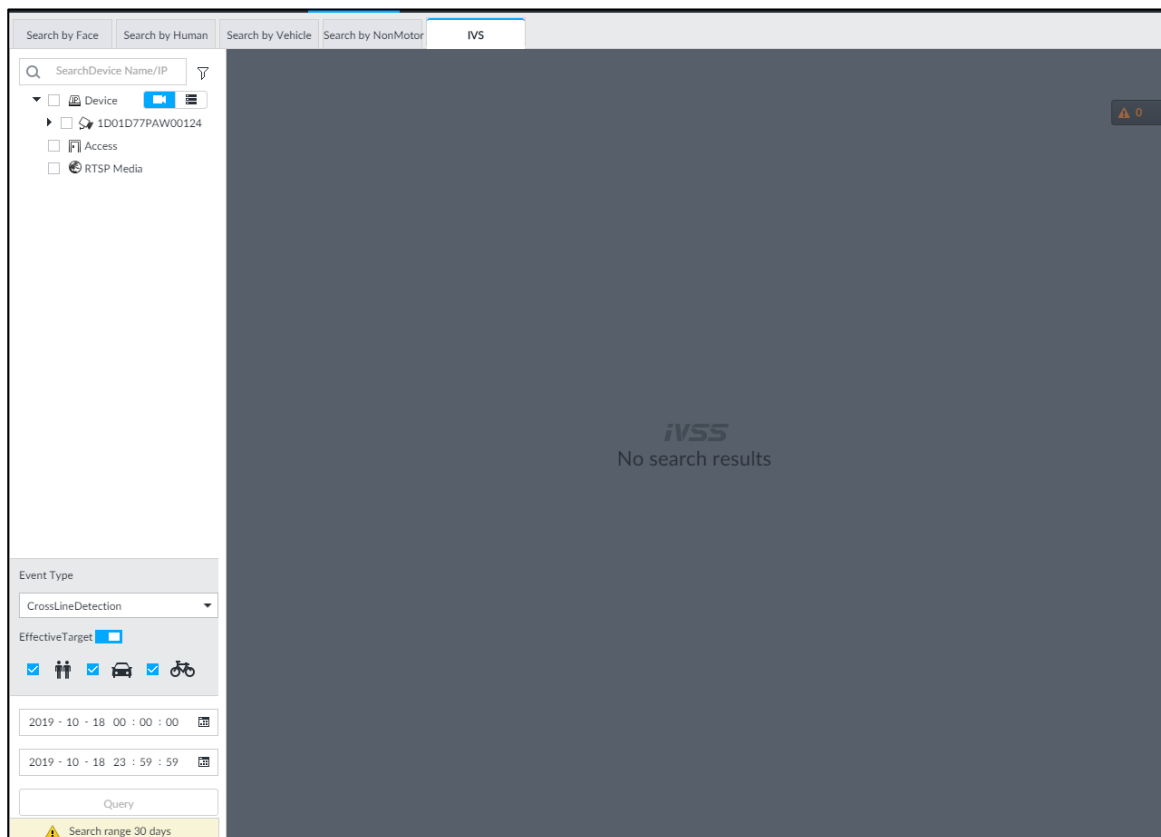
6.6.4 IVS Search

Search for IVS records.

Step 1 On the **LIVE** interface, click  and then select **AI SEARCH > IVS**.

The **IVS** interface is displayed. See Figure 6-84.

Figure 6-84 IVS

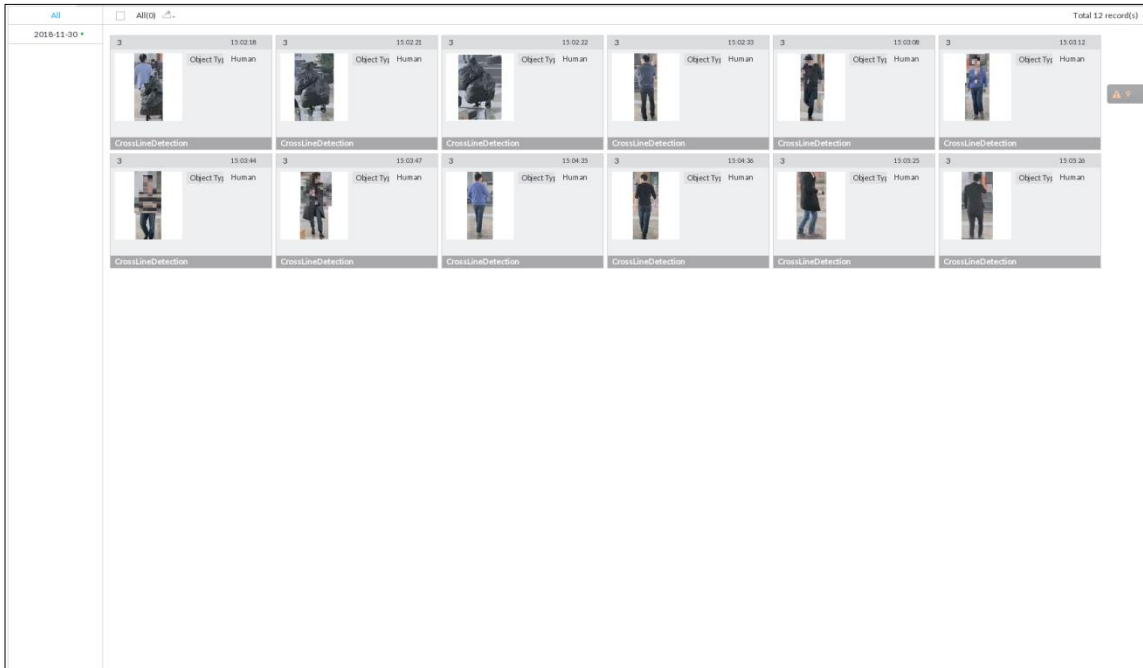


Step 2 Select the remote device, and set event type, effective target and time.

Step 3 Click **Query**.







The search results are displayed in the panel. See Figure 6-85.

Figure 6-85 Search result



Click the panel. The following operation icons are displayed. See Table 6-16.

Table 6-16 More operations

Name	Operation
Select a panel	<ul style="list-style-type: none"> Select one by one: Move the mouse pointer onto the panel. Click  to select the panel.  means it is selected. Click ALL to select all the panels.
Playback	<p>Click the panel, and click  or double-click the panel. The system starts to play back the recorded videos (10 s before and after the snapshot).</p>
Export file	<ul style="list-style-type: none"> Export one by one: Click  to export picture, video and excel. For details, see "6.2.4.3 Exporting Face Records." Export in batches: Select the panel and click  to export picture, video and video player. For details, see "6.2.4.3 Exporting Face Records." <p></p> <p>After setting alarm linkage snapshot, during exporting images, the system exports detected images and panoramic images at the time of snapshot.</p>

6.7 Vehicle Recognition

Alarm is triggered when vehicle property that meets detection rule is detected.



IVSS supports only vehicle recognition through AI by camera. Make sure that the vehicle recognition parameters of camera are configured. For details, see the user's manual of the camera.

6.7.1 Enabling AI Plan

Before using AI by camera, AI plan needs to be enabled first. For details, see "6.2.1 Enabling AI Plan."

6.7.2 Setting Vehicle Recognition

Set the deployment time of vehicle recognition and alarm linkage event.

Step 1 Click  or , and then select **EVENT**.

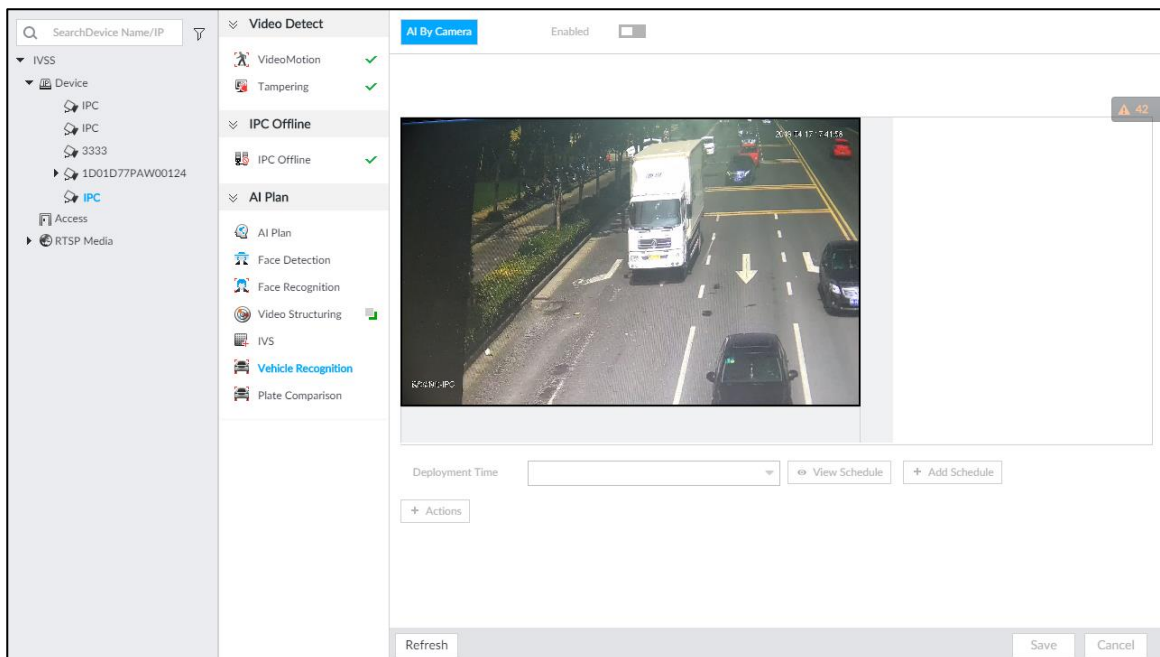
The **EVENT** interface is displayed.

Step 2 Select device from the device tree at the left side.

Step 3 Select **AI Plan > Vehicle Recognition**.

The **Vehicle Recognition** interface is displayed. See Figure 6-86.

Figure 6-86 Vehicle recognition



Step 4 Click the **Deployment Time** drop-down list to select schedule.

IVSS links alarm event when alarm is triggered within the defined schedule.

- Click **View Schedule** to view detailed schedule settings.
- If the schedule is not added or the added schedule does not meet actual needs, click **Add Schedule**. For details, see "8.8.4 Schedule."

Step 5 Click **Actions** to set alarm action. For details, see "8.4.1 Alarm Actions."

Step 6 Click **Save**.

6.7.3 Live View of Vehicle Recognition

View vehicle recognition results on the **LIVE** interface.


6.7.3.1 Setting AI Display

Set the display rules of detection results.



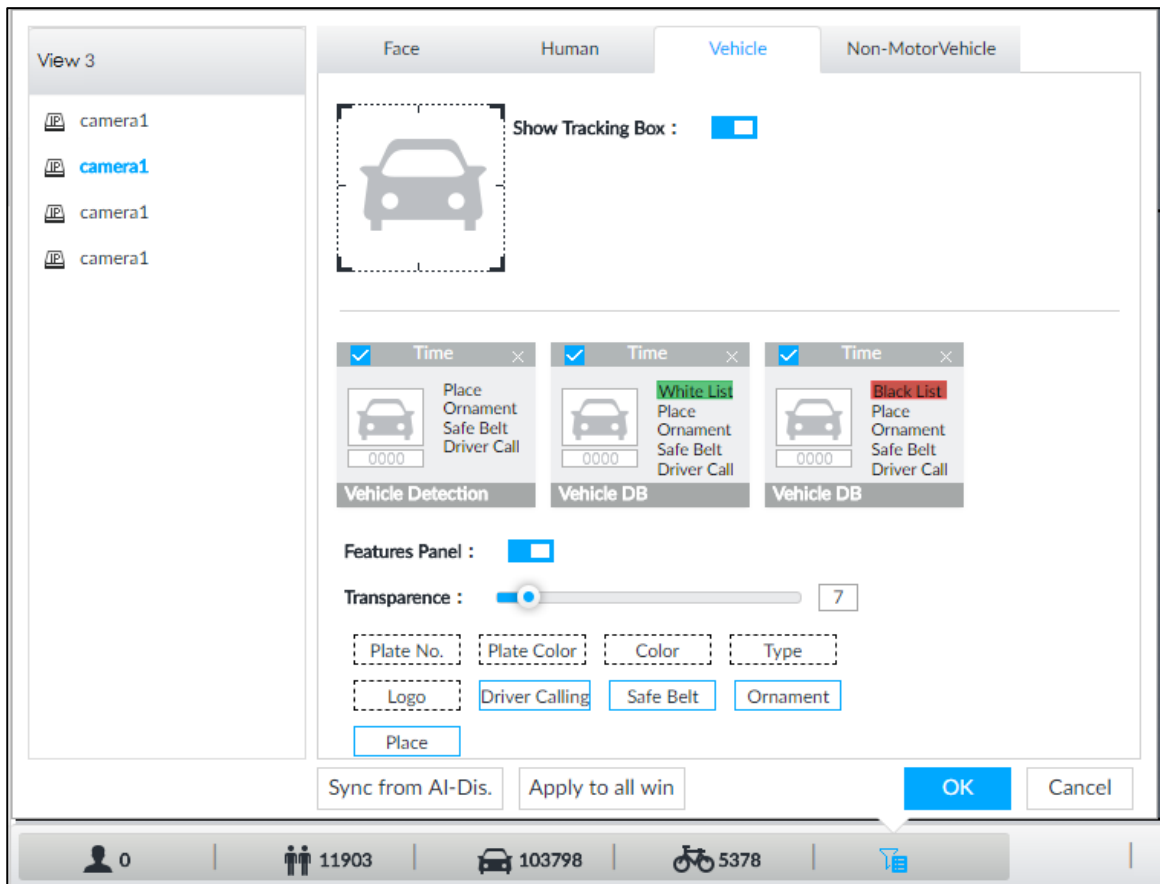
Make sure that view is created before setting AI display. To create view, see "7.1.1 View Management."

Step 1 Select a view from **LIVE > View > View Group**.

Step 2 Click , and then select **Vehicle** tab.

The **Vehicle** interface is displayed. See Figure 6-87.

Figure 6-87 Motor vehicle




Step 3 Click  next to **Show Tracking Box** to enable tracking box function.

A tracking box is displayed in the video image when target meeting detection rule is detected.

Step 4 Set features panel.

1) Click  next to **Features Panel** to enable features panel function.

Features panel will be displayed at the right side of video image when target with selected features is detected.

- 2) Select the **Vehicle Detection** panel type by clicking . means the panel is selected.
- 3) (Optional) Drag  to adjust the transparency of panel. The higher the value, the more transparent the panel.
- 4) (Optional) Select the features to be displayed in the panel.
 - Up to 4 features can be displayed.
 - 4 features are selected by default. To select another feature, click the selected feature to cancel it, and then click the feature to be displayed.

Step 5 Click **OK**.

6.7.3.2 Live View



On the **LIVE** interface, select a view, and the video image of the view is displayed. See Figure 6-88.

- Tracking box is displayed in the video image.
- Features panel is displayed at the right side of the video image.


Figure 6-88 Live



Move the mouse pointer to the features panel, and the operation icons are displayed.

- Click  to add license plate information to the plate database. For details, see "6.8.3.2.3 Adding from Detection Results."
- Click  or double-click the vehicle image to play back the video image (10 s before and after the snapshot).

6.7.3.3 Detection Statistics

On the **LIVE** interface, select a view and then click . The **VEHICLE TOTAL** interface is displayed.


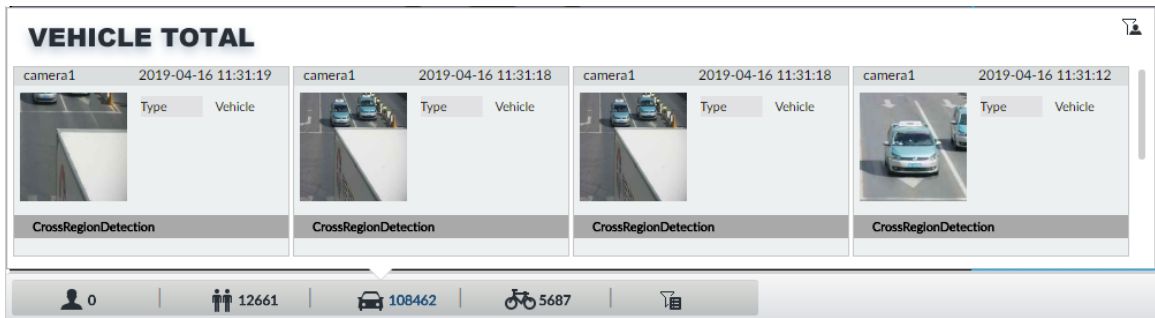



Click , and then select **Vehicle Detection**. The information of detected vehicles is displayed. See Figure 6-89.

Figure 6-89 Vehicle detection



- Move the mouse pointer to the information panel, and then click  to add license plate information to plate database. For details, see "6.8.3.2.3 Adding from Detection Results."
- Move the mouse pointer to the information panel, and then click  or double-click the picture to play back the video image (10 s before and after the snapshot).
- Move the mouse pointer to the information panel, and then click  to export the video and picture to specified saving path.



Make sure that USB storage device is connected during local operation.

6.7.4 Searching for Detection Information

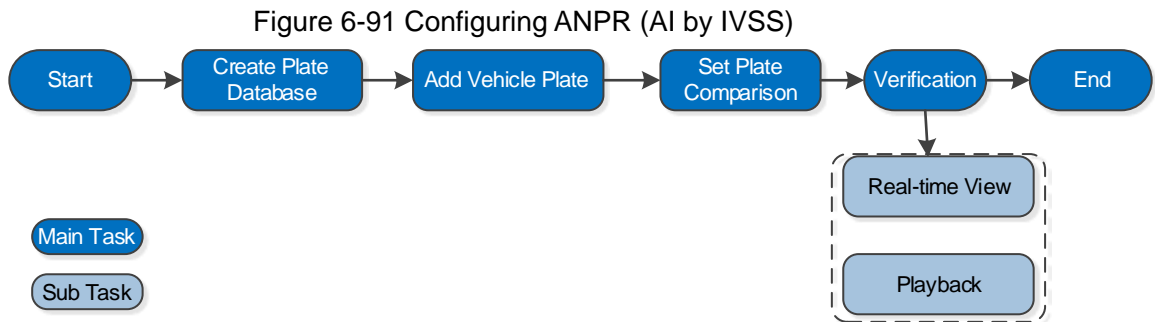
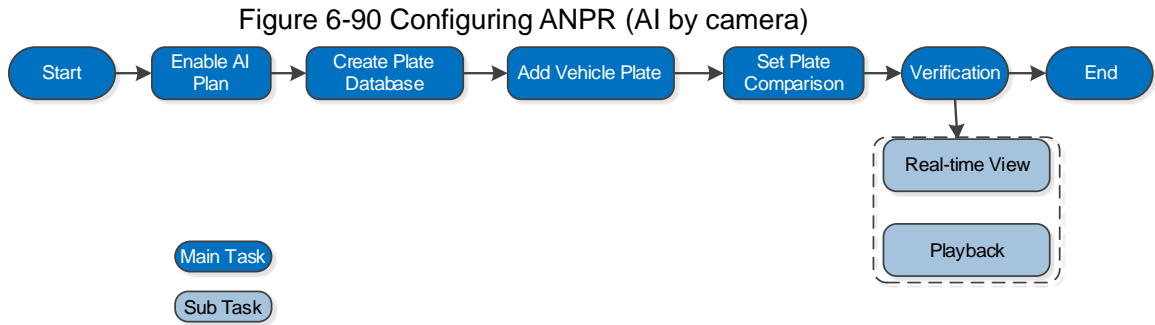
Set event type and vehicle properties, and then search vehicle detection information. For details, see "6.5.4.2 Vehicle Search."

6.8 ANPR

You need the ANPR (Automatic Number Plate Recognition) feature to monitor and control vehicle entry & exit. The system detects vehicle number plates in real time, and compares the detected number plates with the ones in the database. For trusted vehicles, the system lets them in by automatically opening the barrier gate; for unwelcome vehicles, you can keep your barrier gate closed to prevent them from coming in.

This section introduces how to configure the ANPR business from creating vehicle database to setting live ANPR view.

6.8.1 Procedure



6.8.2 Enabling AI Plan


Before using AI by camera, AI plan needs to be enabled first. For details, see "6.2.1 Enabling AI Plan."

6.8.3 Configuring Vehicle Database

Set vehicle database, and then IVSS can compare vehicle plates with information in the database.

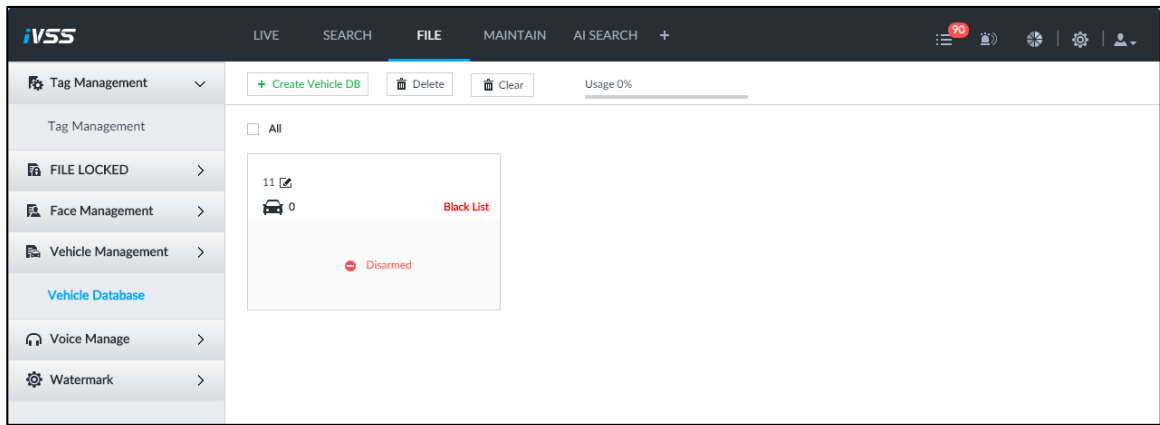
6.8.3.1 Creating Vehicle Database

Create vehicle database, and then classify and manage the database. Database of safe trusted vehicle list and blocked vehicle list can be created.

Step 1 On the **LIVE** interface, click , and then select **FILE > Vehicle Management > Vehicle Database**.

The **Vehicle Database** interface is displayed. See Figure 6-92.

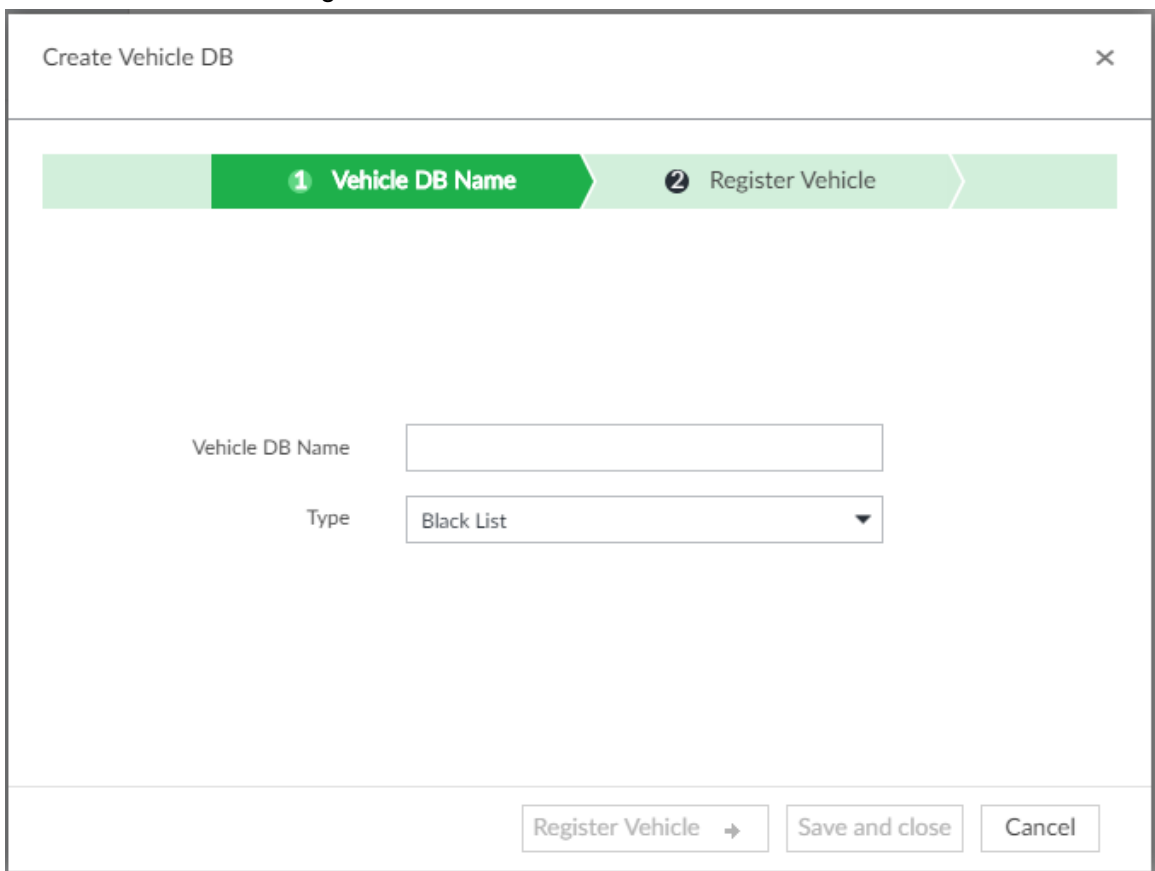
Figure 6-92 Vehicle database



Step 2 Click **Create Vehicle DB**.

The **Create Vehicle DB** interface is displayed. See Figure 6-93.

Figure 6-93 Create vehicle database



Step 3 Set **Vehicle DB Name**, and select **Type** of vehicle database.

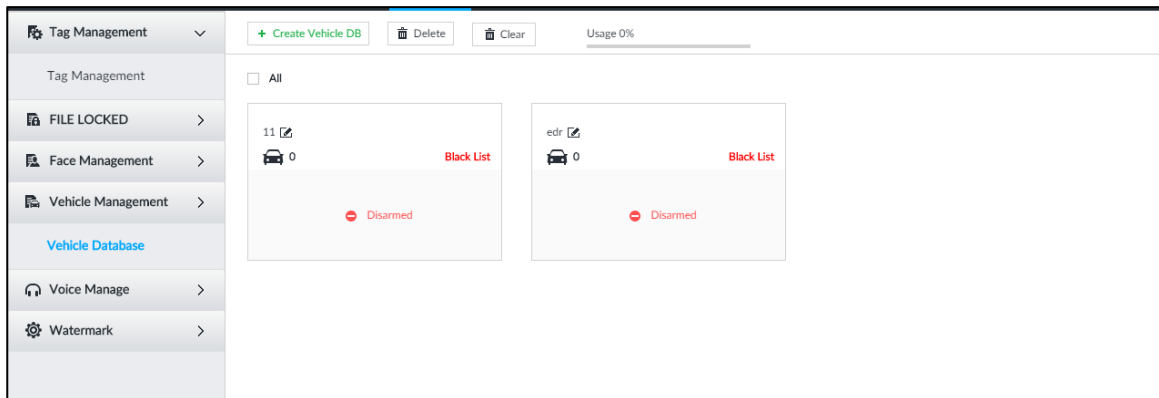
Step 4 Click **Register Vehicle** or **Save and close**.

- Click **Register Vehicle**, and add the vehicle information to the database. See Figure 6-94. For details, see "6.8.3.2 Registering Vehicle Information."

Figure 6-94 Register vehicle plate

- Click **Save and close** to create a database without editing its information. The newly-created database can be viewed on the **Vehicle Database** interface. See Figure 6-95.







Figure 6-95 Vehicle database



Other Operations

After creating a database, you can modify the database name, register plate information, arm the database, and delete the database. See Table 6-17.


Table 6-17 Other operations

Operation	Description
View database information and status	<ul style="list-style-type: none"> ● Database 2 : Database name. ●  1: Number of vehicle plate in the database. ● Black List / White List : The database is in the blocked/trusted list. ●  Disarmed : The database is not linked to channel for vehicle plate comparison. If armed, the linked device channel will be displayed.
Modify database name	Click  next to the database name to modify its name.
Manage database	Double-click the database, and you can manage the vehicle plate information in the database. For details, see "6.8.3.3 Managing Vehicle Information."
Arm database	Link the database to camera channel for vehicle plate comparison. For details, see "6.8.4 Configuring Number Plate Comparison."
Delete database	<ul style="list-style-type: none"> ● Delete one by one: Move the mouse pointer to the database, and click  at the upper right corner to delete it. ● Delete in batch: Move the mouse pointer to a database, and check <input type="checkbox"/> to select the database. Select multiple databases in this way, and then click  Delete to delete the selected databases. ● Delete all: Select All, and then click  Delete to delete all databases.

6.8.3.2 Registering Vehicle Information

Add vehicle information to the created database. You can add vehicles one by one, in batches or directly add from the detection results.

6.8.3.2.1 Manual Add

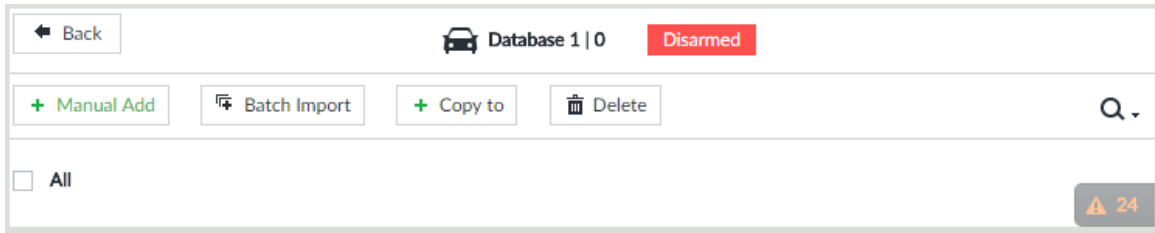
Step 1 On the **LIVE** interface, click , and then select **FILE > Vehicle Management > Vehicle Database**.

The **Vehicle Database** interface is displayed.

Step 2 Double-click the database.

The database interface is displayed. See Figure 6-96.

Figure 6-96 Database




Step 3 Click **Manual Add**.

The **Vehicle Register** interface is displayed. See Figure 6-97.

Figure 6-97 Vehicle register

Step 4 Set the parameters. See Table 6-18.

Table 6-18 Vehicle register parameters

Parameters	Description
Country or Region	The country or region that the vehicle belongs to.
Name	Driver name.
Driver ID	Driver license number.
Cell Phone	Driver phone number.
Email	Driver email.
Address	Driver address.
Plate	Vehicle plate number.
Logo	Vehicle logo.
Color	Click  to select the color of vehicle.



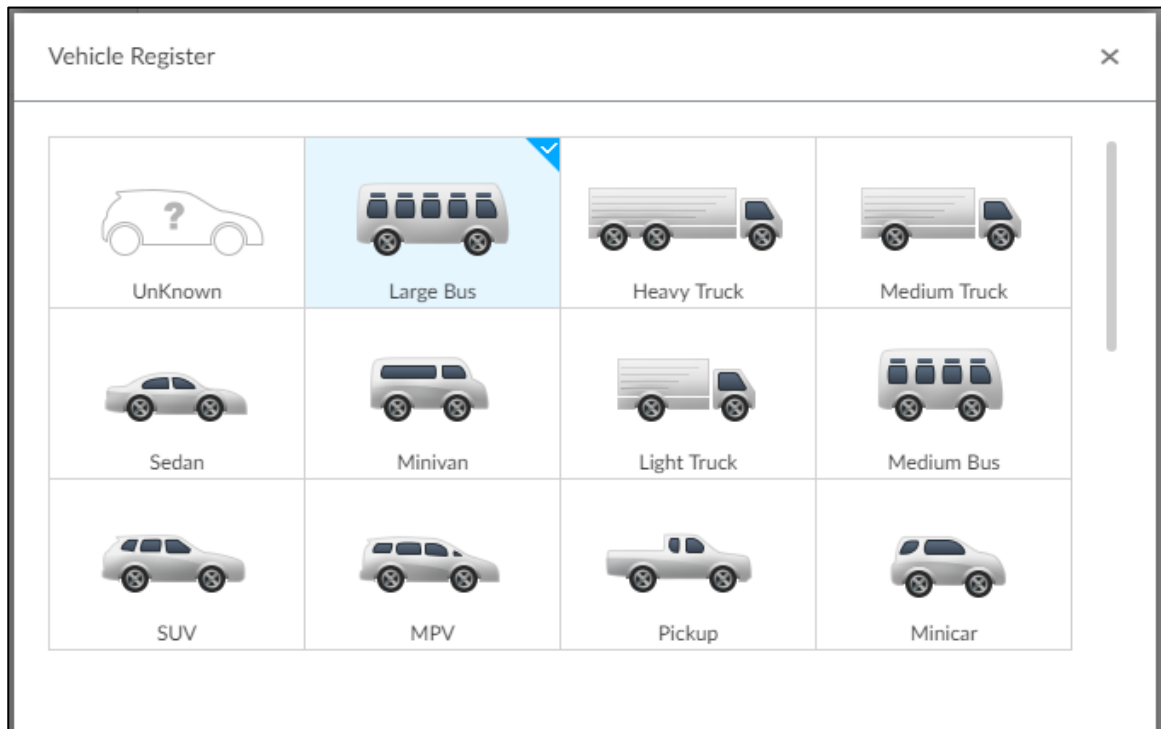
Parameters	Description
Plate Color	Click  to select the color of vehicle plate.
Type	Click  , and you can select the vehicle type. See Figure 6-98. Blue means already selected.

Figure 6-98 Vehicle type

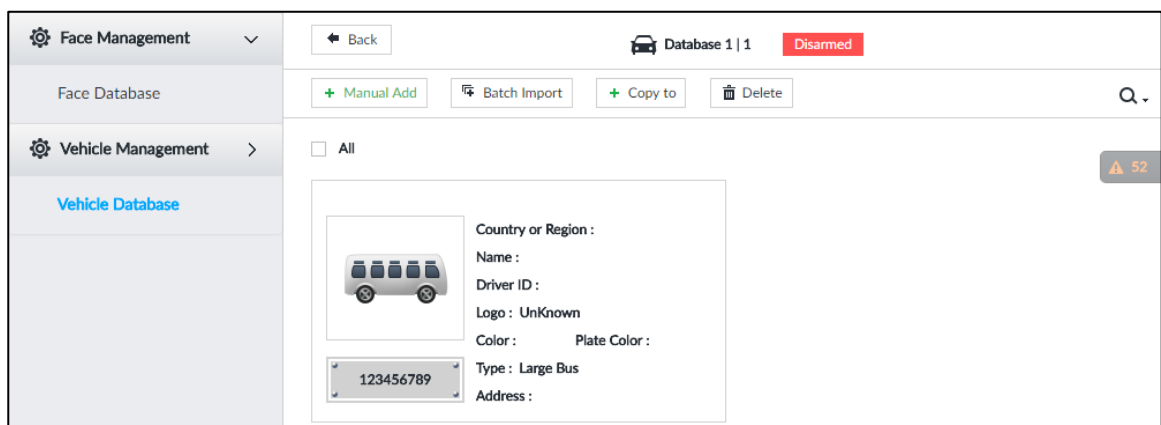


Step 5 Click **Save and continue** to add or **OK**.

- Click **Save and continue to add**: Save the current vehicle information, and then **Continue to add** next vehicle.
- Click **OK**: Save the current vehicle information.


The added vehicle information is displayed. See Figure 6-99.

Figure 6-99 Vehicle information



6.8.3.2.2 Batch Import

Import vehicle information in batches.

Step 1 On the **LIVE** interface, click , and then select **FILE > Vehicle Management > Vehicle Database**.

The **Vehicle Database** interface is displayed.

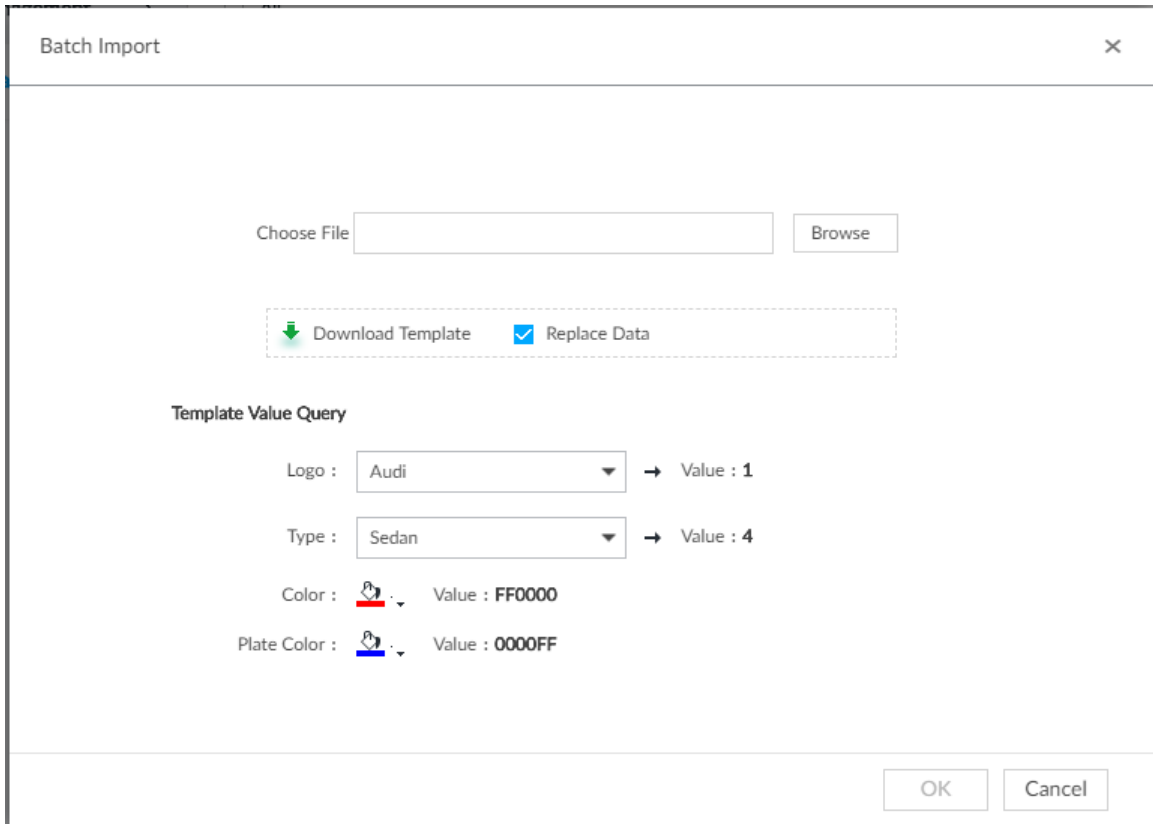
Step 2 Double-click the database.

The database interface is displayed.

Step 3 Click **Batch Import**.

The **Batch Import** interface is displayed. See Figure 6-100.




Figure 6-100 Batch import



Step 4 Acquire and fill in the template file.

- 1) Click **Download Template** to download the template to local PC or USB storage device.

The saving path might vary when operating on client or local interface, and the actual interface shall prevail.

- On client: Click  on the upper right side, and then select  | **Download** to view the saving path of template file.
- On local interface: Select the saving path of template file.

Make sure that USB storage device is connected during local operation.
- On web interface: Template file is saved in the default download path of browser.

- 2) Fill in the template according to your actual needs. See Figure 6-101.

Fill in the vehicle information according to the instructions. For logo, type, color, and plate color, fill in the corresponding code or value. Search the code or value on the **Batch Import** interface (See Figure 6-100).

Figure 6-101 Template file

Serial No	*Plate No	Country	Logo	Type	Color	Plate Col	Owner	License	Tel	Email	Address
1	BD51SMR	GB		1	2 FFFFFFFF	FFFFFF	Peter	L-PETER12	T-0712345	123@gmail	Birmingham

@@Explain:
 1. With * is required
 2. Country: Conform to ISO3166 specification. 2 bytes uppercase format. Example Great Britain GB Chinese CN.
 3. Logo: Please input code number of vehicle logo. Example Bentley 54. The code number can be querying on the page of downloaded this.
 4. Type: Please input code number of vehicle type. Example SaloonCar 4. The code number can be querying on the page of downloaded this.
 5. Vehicle Color: Please input RGB color. Example Red FF0000. The code number can be querying on the page of downloaded this.
 6. Plate Color: Please input RGB color. Example Red FF0000. The code number can be querying on the page of downloaded this.
 7. License: Please add prefix 'L'.
 8. Tel: Please add prefix 'T'.

3) Save template file.

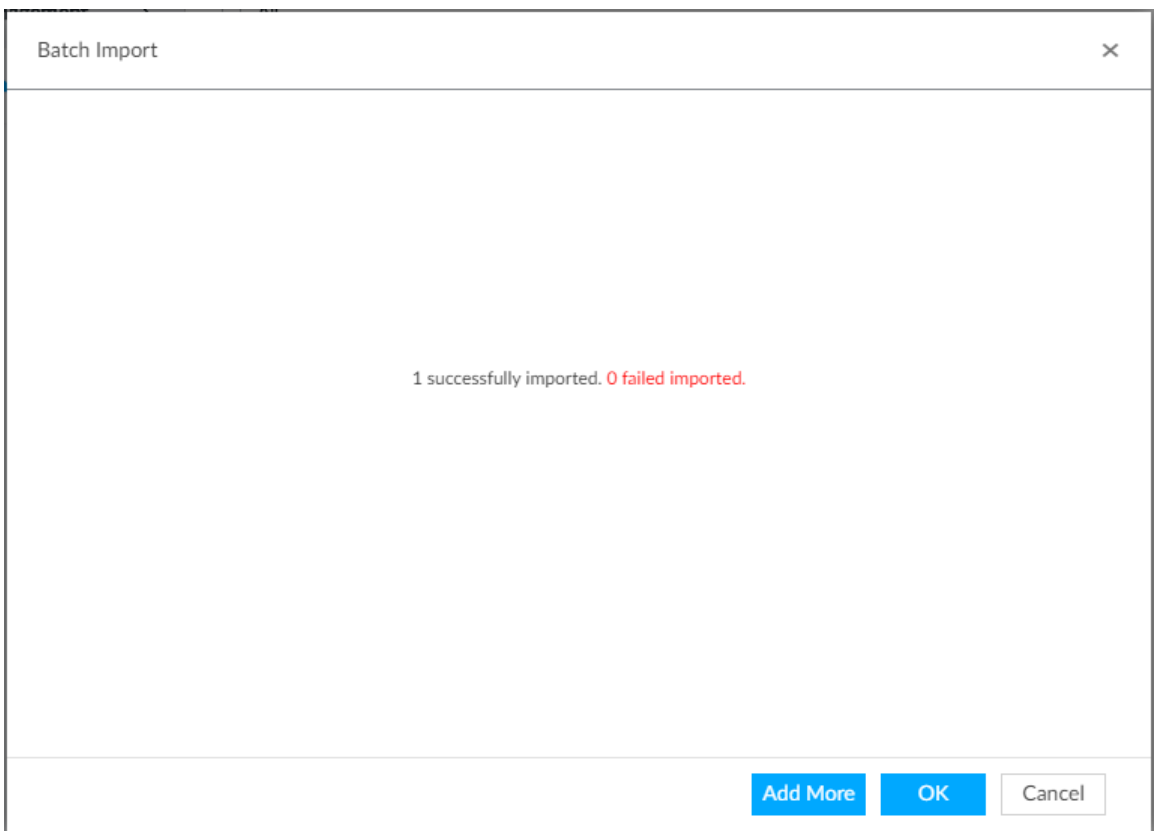
Step 5 On the **Batch Import** interface, click **Browse** to import template file.

If the plate number in the template is the same as the number in the database, select **Replace Data** to overlap the information in the database.

Step 6 Click **OK**.

The batch import result is displayed. See Figure 6-102.

Figure 6-102 Batch import result

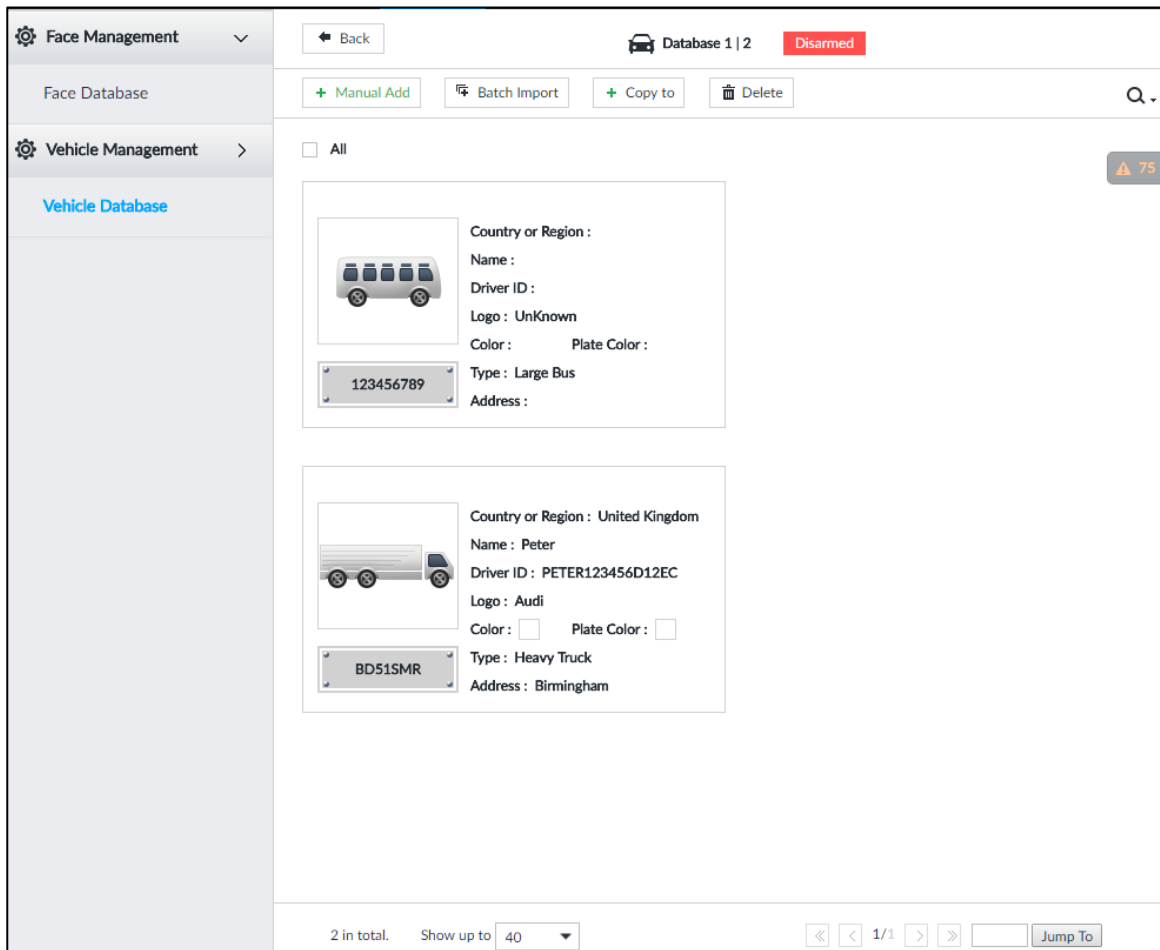


Step 7 Click **Add More** or **OK**.

- Click **Add More**: Import vehicle information, and **Continue to add** vehicle information.
- Click **OK**: Import vehicle information.

The added vehicle information can be viewed on the **Vehicle Database** interface. See Figure 6-103.




Figure 6-103 Vehicle information



6.8.3.2.3 Adding from Detection Results

Add plate information from vehicle recognition or detection results to the database.

Step 1 On the **LIVE** interface, select the vehicle information to be added.

- Click , move the mouse pointer to the information panel, and then click .
- On the **Vehicle Recognition** or **Video Metadata** interface, move the mouse pointer to the vehicle recognition or vehicle detection panel, and then click .

The **Vehicle Register** interface is displayed. See Figure 6-104.

Figure 6-104 Vehicle register

Vehicle Register

Vehicle DB: Select

Country or Region: [dropdown]

Name: [text input]

Driver ID: [text input]

Cell Phone: [text input]

Email: [text input]

Address: [text input]

Plate: [text input]

Logo: [dropdown]

Color: [color picker] Plate Color: [color picker]

Type: [image selection area: UnKnown]


OK Cancel

Step 2 Select **Vehicle DB**, and enter **Plate**. Other information can be filled in according to actual conditions.

Step 3 Click **OK**.

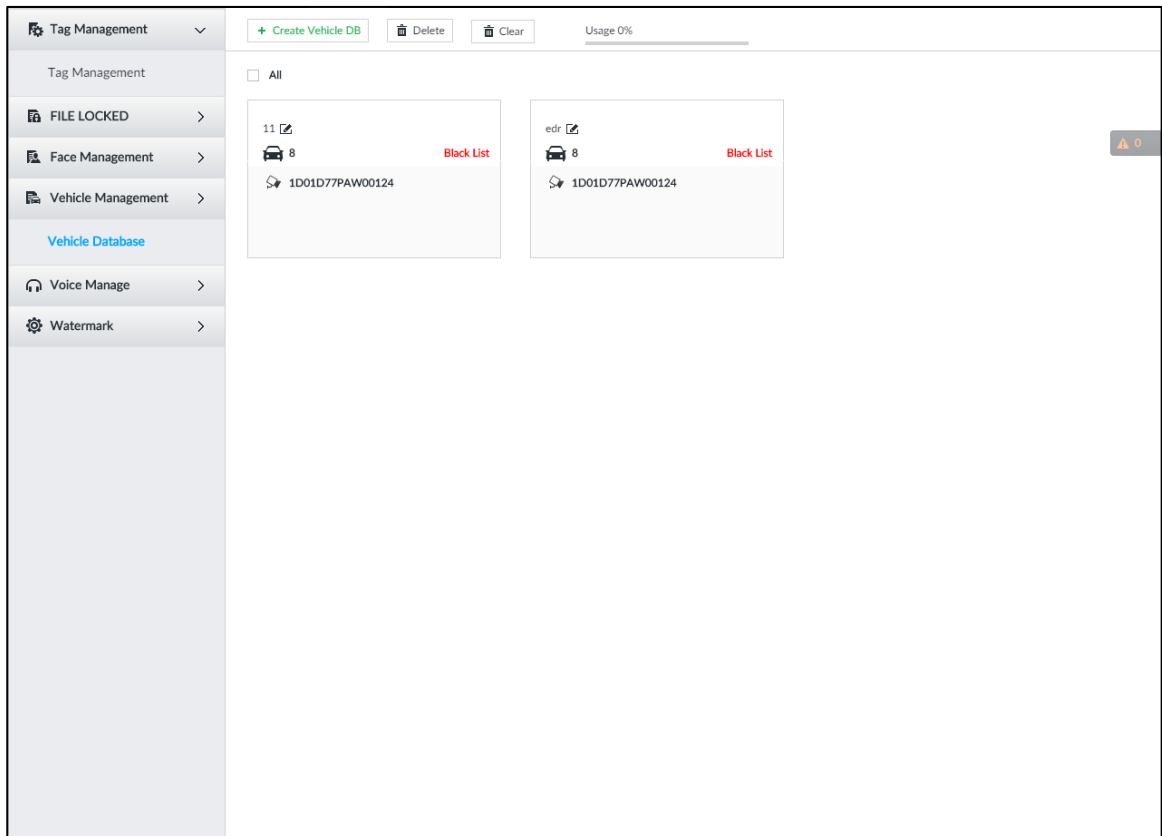
6.8.3.3 Managing Vehicle Information

After registering vehicle information, the information needs to be properly managed and maintained to keep it accurate and complete.


On the **LIVE** interface, click , and then select **FILE > Vehicle Management > Vehicle Database**. The database interface is displayed. See Figure 6-105.

On the interface, the information can be edited, copied, or deleted.

Figure 6-105 Database



6.8.3.3.1 Editing Vehicle Information

Step 1 Move the mouse pointer to the database, and then click  .

The **Edit** interface is displayed. See Figure 6-106.

Figure 6-106 Edit

The 'Edit' dialog box contains the following fields and options:

- Country or Region: A dropdown menu.
- Name: A text input field.
- Driver ID: A text input field.
- Cell Phone: A text input field.
- Email: A text input field.
- Address: A text input field.
- Plate: A text input field containing '123456789'.
- Logo: A dropdown menu showing 'UnKnown'.
- Color: A color selection icon.
- Plate Color: A color selection icon.
- Type: A dropdown menu showing 'Large Bus' with a bus icon and an up arrow.

At the bottom right, there are 'OK' and 'Cancel' buttons.

Step 2 Modify vehicle information according to actual needs.

Step 3 Click **OK**.

6.8.3.3.2 Copying Vehicle Information

Copy the vehicle information in a database to another database. You can only copy and apply the vehicle information to a database of the same type. For example, vehicle information in a black list database can only be copied to another black list database.

Step 1 Move the mouse pointer to the database, and then click .

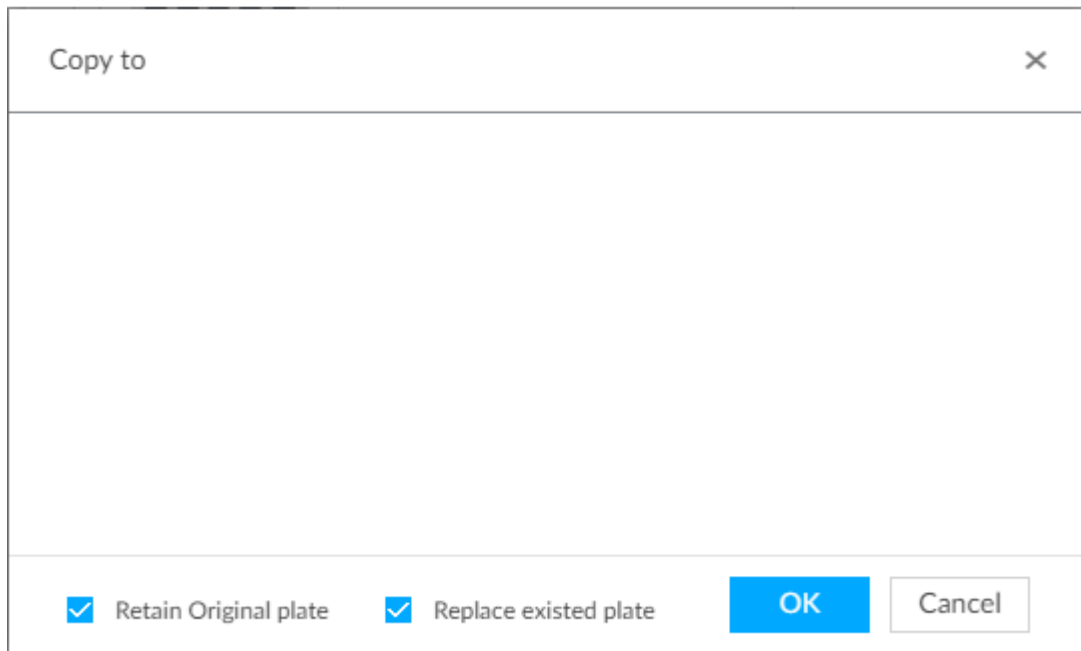


- Multiple vehicle information can be selected at a time.
- Select **All** to select information of all vehicles on the interface.

Step 2 Click .


The **Copy to** interface is displayed. See Figure 6-107.

Figure 6-107 Copy to




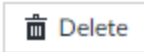

Step 3 Select the target database.



- Multiple databases can be selected at a time. Blue means already selected, for example .
- Select **Retain Original plate**: When the same plate is detected, the vehicle information in the target database will not be replaced.
- Select **Replace existed plate**: When the same plate is detected, the vehicle information in the target database will be replaced.

Step 4 Click **OK**.

6.8.3.3 Deleting Vehicle Information

- Delete one by one: Move the mouse pointer to the database, and then click  at the upper right corner to delete the database.
- Delete in batch
 - ◇ Move the mouse pointer to the database, and then click at the upper left corner to select the database. Select multiple databases in this way, and then click  to delete selected databases.
 - ◇ Select **All**, and then click  to delete all the databases on the interface.

6.8.4 Configuring Number Plate Comparison

Set the alarm triggering rules after plate comparison.



The section takes AI by device for example, and the actual interface shall prevail.

Step 1 Click  or  on the configuration interface, and then select **EVENT**.

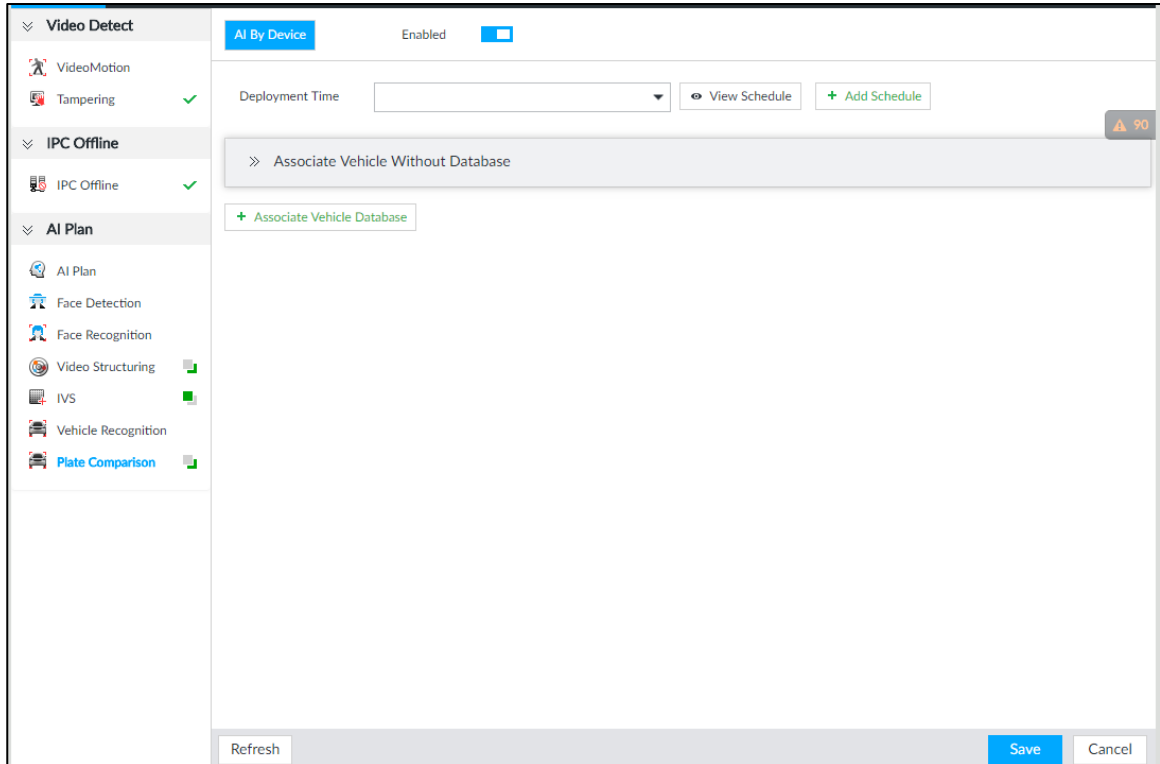
The **EVENT** interface is displayed.

Step 2 Select device from the device tree on the left side.

Step 3 Select **AI Plan > Plate Comparison**.

The **Plate Comparison** interface is displayed. See Figure 6-108.

Figure 6-108 Plate comparison



Step 4 Click  to enable plate comparison. The icon changes to .

Step 5 Click **Deployment Time** drop-down list to select schedule.

IVSS links alarm event when an alarm is triggered within the schedule configured.

- Click **Add Schedule** to add new schedule if no schedule is added or the existing schedule does not meet requirements. For details, see "8.8.4 Schedule."
- Click **View Schedule** to view details of schedule.

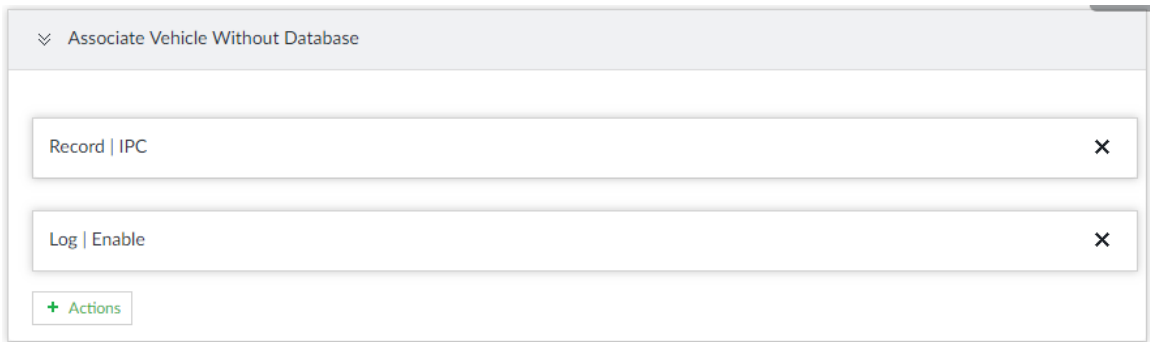
Step 6 Link vehicle without database.

Enable linkage of vehicle without database. Alarm is triggered when vehicle not in the database is detected.

1) Click .

The **Associate Vehicle Without Database** interface is displayed. See Figure 6-109.

Figure 6-109 Associate vehicle without database



+ Associate Vehicle Database

2) Click **Actions** to set alarm linkage event. For details, see "8.4.1 Alarm ."

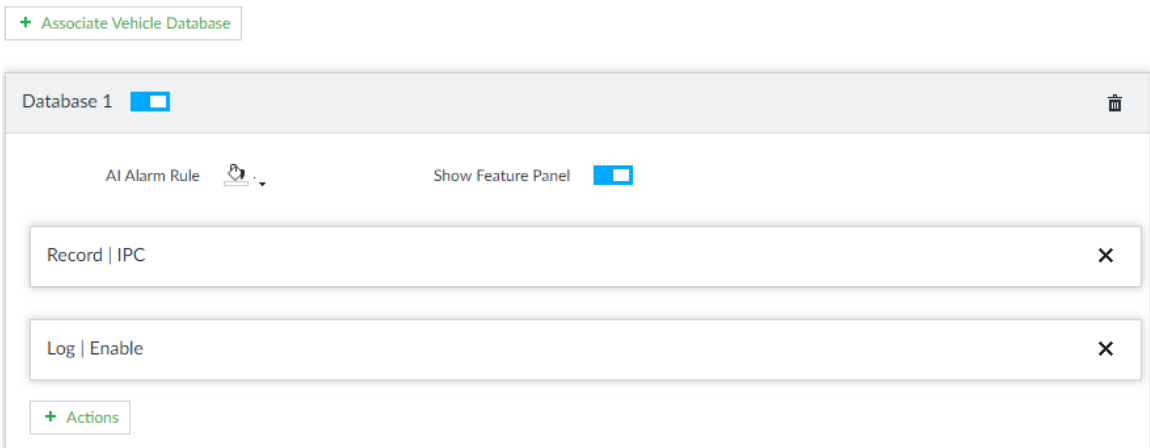
Step 7 Link database.



Repeat the following steps to link multiple databases.



1) Click **Associate Vehicle Database**, and select the database to be linked. The database linkage interface is displayed. See Figure 6-110.

Figure 6-110 Database linkage



2) Set the parameters. See Table 6-19.

Table 6-19 Database linkage parameters

Parameters	Description
AI Alarm Rule	Click  to set the color of alarm rule box.
Show Feature Panel	Click  , and when alarm is triggered, the plate comparison information is displayed in the feature panel of video image.

3) Click **Actions** to set alarm linkage event. For details, see "8.4.1 Alarm ."

Step 8 Click **Save**.

6.8.5 Live View of ANPR

View vehicle comparison results on the **LIVE** interface.


6.8.5.1 Setting AI Display

Set the display rules of detection results.



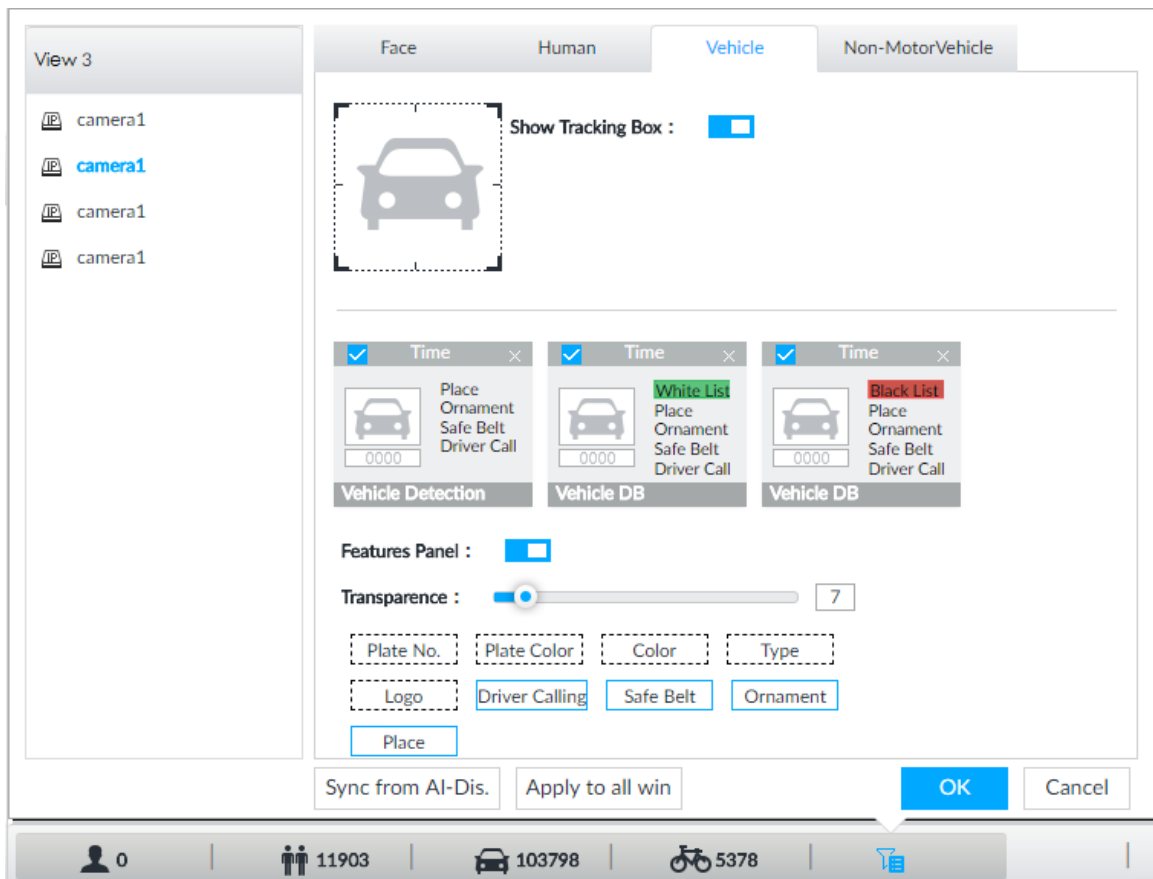
Make sure that view is created before setting AI display. To create view, see "7.1.1 View Management."

Step 1 Select a view from **LIVE > View > View Group**.

Step 2 Click , and then select **Vehicle** tab.

The **Vehicle** interface is displayed. See Figure 6-111.


Figure 6-111 Vehicle



Step 3 Click next to **Show Tracking Box** to enable tracking box function.

A tracking box is displayed in the video image when target meeting detection rule is detected.

Step 4 Set features panel.

- 1) Click next to **Features Panel** to enable features panel function.
Features panel will be displayed at the right side of video image when target with selected features is detected.
- 2) Click to select the **Vehicle DB** panel. means the panel is selected.
- 3) (Optional) Drag  to adjust the transparency of panel. The higher the value, the more transparent the panel.
- 4) (Optional) Select the features to be displayed in the panel.

- Up to 4 features can be displayed.
- 4 features are selected by default. To select another feature, click the selected feature to cancel it, and then click the feature to be displayed.

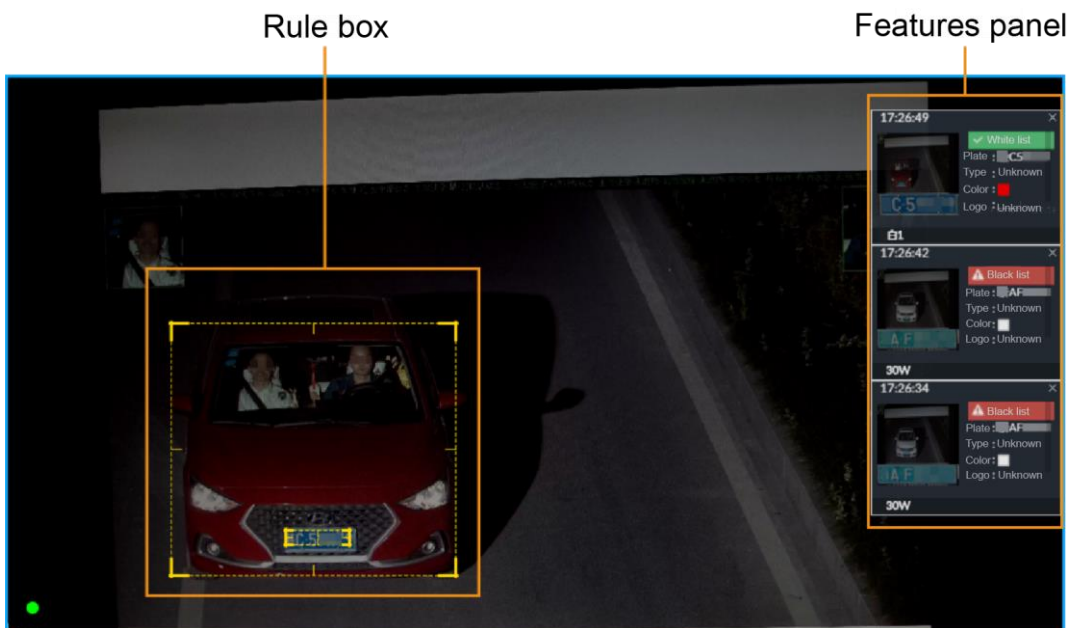
Step 5 Click **OK**.

6.8.5.2 Live View

On the **LIVE** interface, select a view, and the video image of the view is displayed. See Figure 6-112.

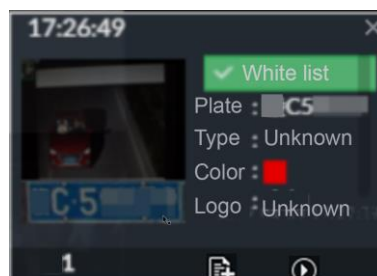
- Tracking box is displayed in the video image.
- Features panel is displayed at the right side of the video image.



Figure 6-112 Live




Move the mouse pointer to the features panel, and the operation icons are displayed. See Figure 6-113.

Figure 6-113 Icons



- Click  to add license plate information to the plate database. For details, see "6.8.3.2.3 Adding from Detection Results."
- Click  or double-click the vehicle image to play back the video image (10 s before and after the snapshot).

6.8.5.3 Detection Statistics

On the **LIVE** interface, select a view and then click . The **VEHICLE TOTAL** interface is displayed.


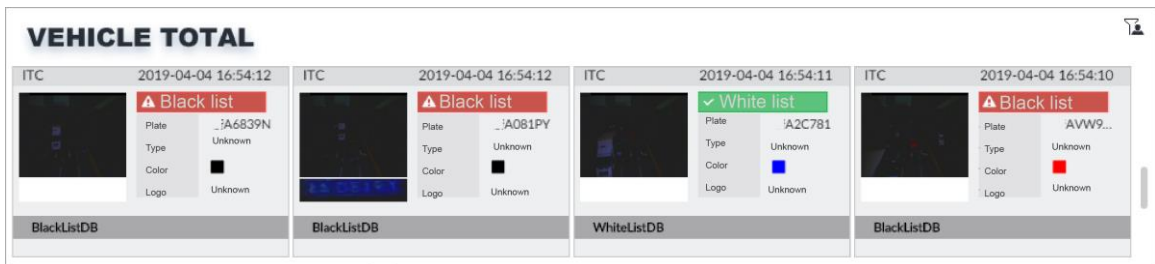



Click , and then select **Vehicle Comparison (Black List)** and **Vehicle Comparison (White List)**. The vehicle comparison result is displayed. See Figure 6-114.

Figure 6-114 Vehicle comparison



- Move the mouse pointer to the information panel, and then click  to add license plate information to plate database. For details, see "6.8.3.2.3 Adding from Detection Results."
- Move the mouse pointer to the information panel, and then click  or double-click the picture to play back the video image (10 s before and after the snapshot).
- Move the mouse pointer to the information panel, and then click  to export the video and picture to specified saving path.




Make sure that USB storage device is connected during local operation.

6.8.6 AI Search

Set search conditions such as device and properties, and then search information that meets the conditions. IVSS supports searching by property and searching by database.

6.8.6.1 Searching by Property

Set search conditions such as device and properties, and then search vehicle recognition information that meets the conditions.

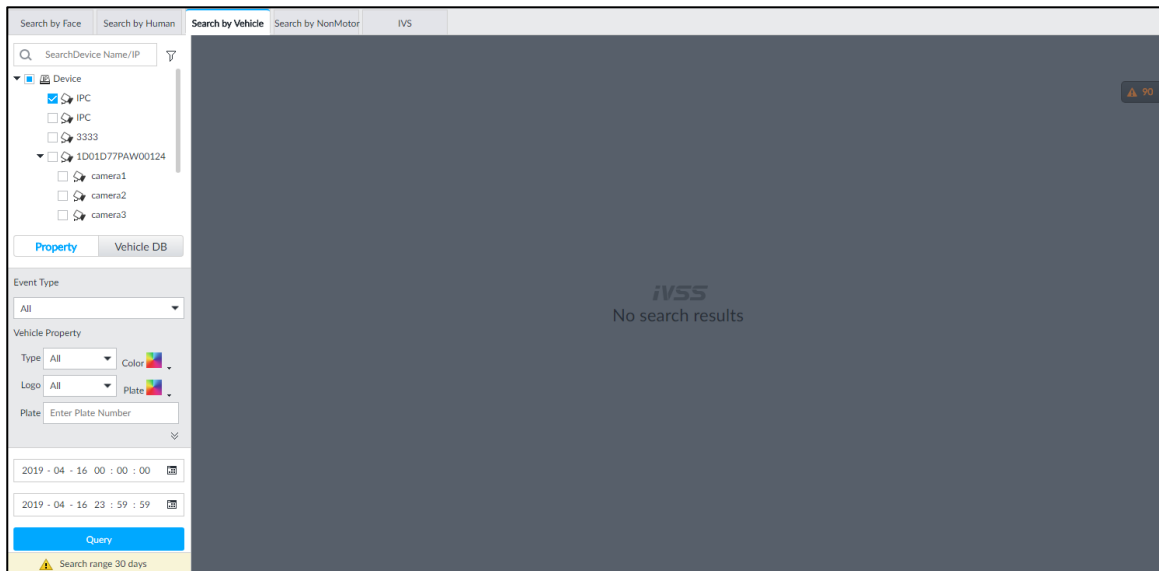
Step 1 On the **LIVE** interface, click , and then select **AI SEARCH > Search by Vehicle**.

The **Search by Vehicle** interface is displayed.

Step 2 Select device, and then click **Property** tab.

The search by property interface is displayed. See Figure 6-115.

Figure 6-115 Search by property



Step 3 Select **Plate Comparison** as the **Event Type**.

Step 4 Set vehicle properties and time period.

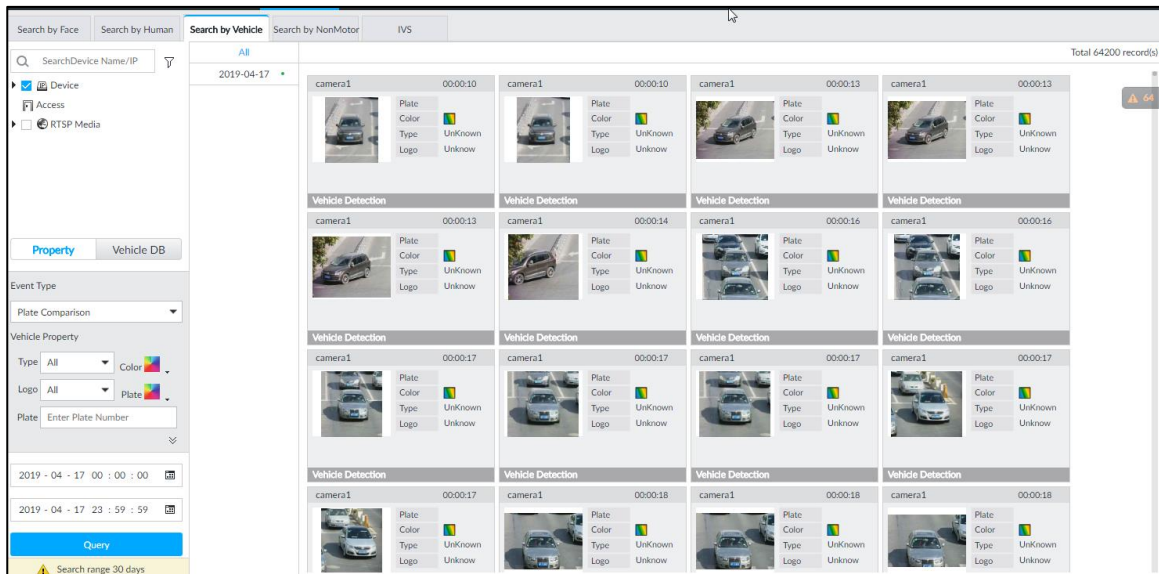
Click  or  to set the color.  means more than one color.

Step 5 Click **Query**.

The search result is displayed. See Figure 6-116.

If license plate is detected, both the scenario and the license plate will be displayed.

Figure 6-116 Search result



Other Operations

Click on one displayed panel, and the icons are displayed. See Figure 6-117 and Table 6-20.

Figure 6-117 Icons

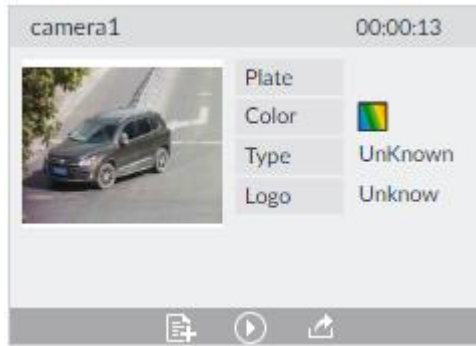


Table 6-20 Operations

Icon	Operation
	<ul style="list-style-type: none"> Select one by one: Move the mouse pointer to the panel, and then click at the upper right side to select the panel. means the panel is selected. Select in batches: Select All to select all the panels on the interface.
	Move the mouse pointer to the panel, and then click or double-click the panel to play back the video record (10 s before and after the snapshot).
	Move the mouse pointer to the panel, and then click to add picture to database. See "6.3.3.2.3 Adding from Detection Snapshots."
	<ul style="list-style-type: none"> Export one by one: Click to export picture, video and excel. For details, see "6.2.4.3 Exporting Face Records." Export in batches: Select the panel and click to export picture, video and video player. For details, see "6.2.4.3 Exporting Face Records." <p> After setting alarm linkage snapshot, during exporting images, the system exports detected images and panoramic images at the time of snapshot.</p>

6.8.6.2 Searching by Database

Search vehicle recognition information according to database.

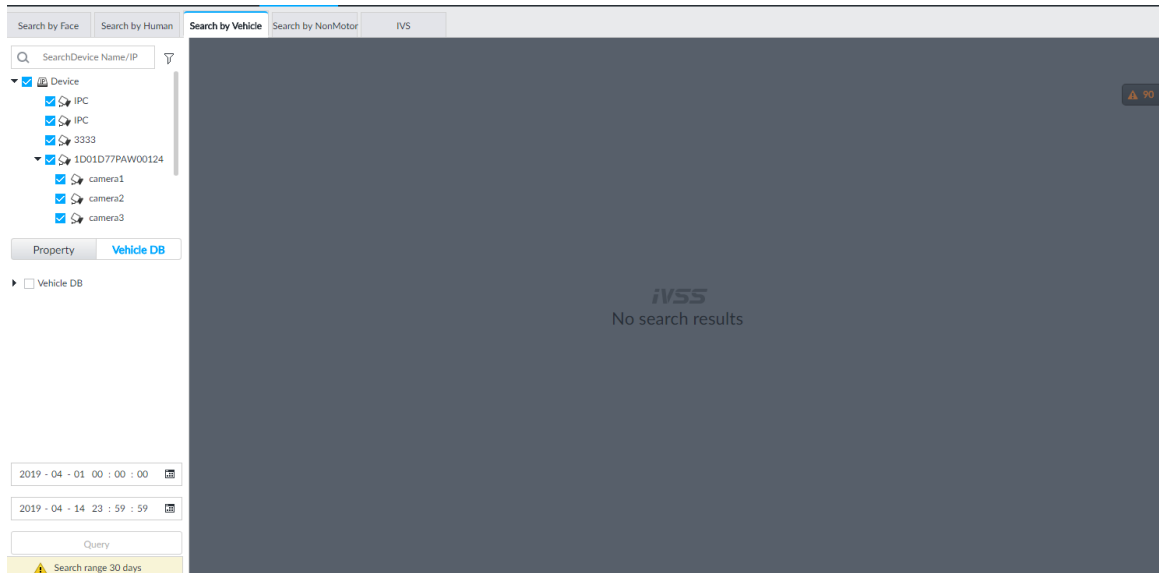
Step 1 On the **LIVE** interface, click , and then select **AI SEARCH > Search by Vehicle**.

The **Search by Vehicle** interface is displayed.

Step 2 Select device from the device tree, and then click **Vehicle DB** tab.

The search by database interface is displayed. See Figure 6-118.

Figure 6-118 Search by vehicle database



Step 3 Select the database to be searched.

Step 4 Click **Query**.

The search result is displayed. If license plate is detected, both the scenario and the license plate will be displayed.

Other Operations

Click one displayed panel, and the icons are displayed. For operations of icons, see "6.8.6.1 Searching by Property."

6.9 Crowd Distribution Map

View and monitor people crowd to avoid crowd incidents, for example, stampede.



This function is only available with AI by camera.

6.9.1 Enabling AI Plan



Enable the corresponding AI plan before using AI by camera functions. For details, see "6.2.1 Enabling AI Plan."

6.9.2 Configuring Crowd Distribution Map

Set crowd distribution alarm rules.

6.9.2.1 Global Configuration

Draw lines on the image to determine the geographical scale of the image.

Step 1 Click  or click  on the configuration interface, and then select **EVENT**.

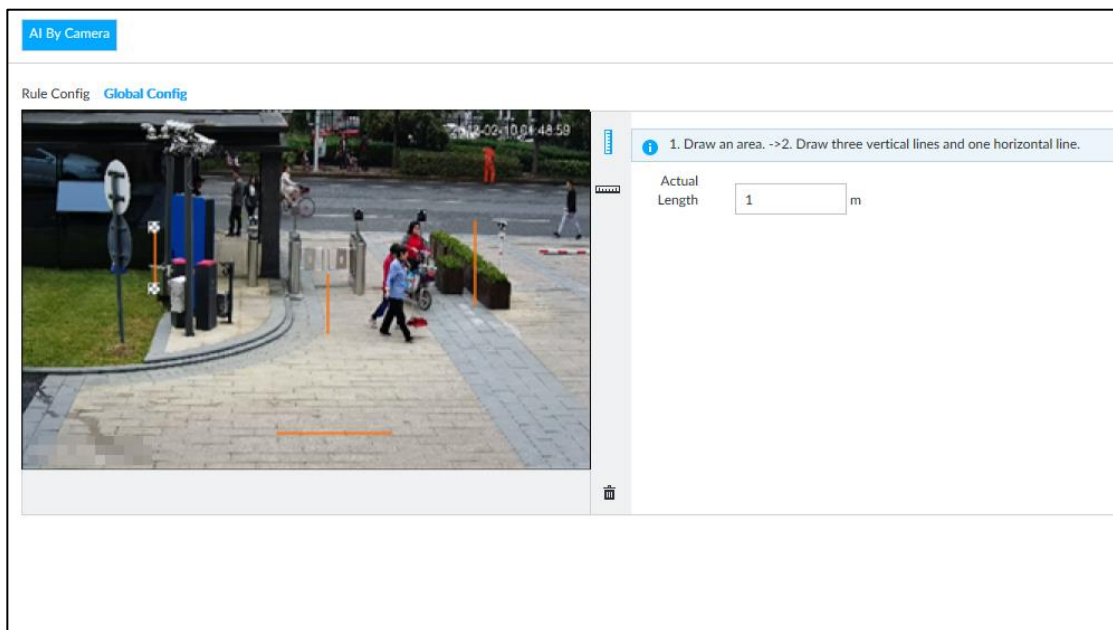
The **EVENT** interface is displayed.

Step 2 In the device tree, select a camera.



Step 3 Select **AI Plan > Crowd Distribution Map > Global Config**.

The **Global Config** interface is displayed.

Figure 6-119 Global config



Step 4 Draw lines. Draw one horizontal line and three vertical lines.

- Click , draw vertical lines, and then enter their geographical distance values.
- Click , draw a horizontal line, and then enter the geographical distance value.

Step 5 Click **Save**.

6.9.2.2 Rule Configuration

Configure the alarm threshold for crowd monitoring. For example, when the crowd density reaches 8, an alarm is triggered.

Step 1 Click  or click  on the configuration interface, and then select **EVENT**.

The **EVENT** interface is displayed.

Step 2 In the device tree, select a camera.

Step 3 Select **AI Plan > Crowd Distribution Map > Rule Config**.

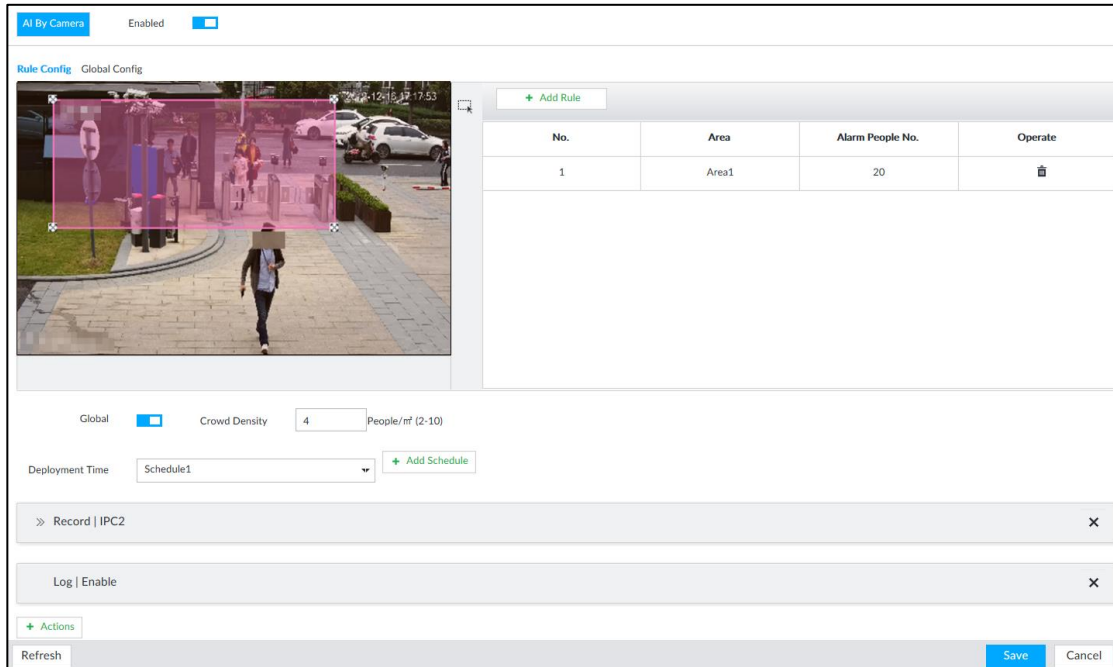
The **Rule Config** interface is displayed.

Step 4 Click next to **Enabled** to enable rule configuration.

Step 5 Set detection rules.

- Set regional detection rules.
- 1) Click **Add Rule**. The following interface is displayed.

Figure 6-120 Add Rules



- 2) Drag to adjust the size.
 - 3) Configure alarm threshold. Alarm is triggered when the detected people number reaches the threshold.
- Set global alarm.

- 1) Click , and then drag to adjust the size of the yellow area.

- 2) Click to enable global detection.

- 3) Set crowd density. Alarm is triggered when the detected crowd density reaches the threshold.

Step 6 Select a schedule from the **Deployment Time** drop-down list.

The alarm linkage action is triggered only during the scheduled period.



To modify the schedule, click **Add Schedule**.

Step 7 Click **Actions**, and then select an action to be associated to the alarm.

Step 8 Click **Save**.

6.9.3 Live View of Crowd Distribution

On the **LIVE** interface, open a view that contains the crowd distribution detection camera.

The video shows people numbers and distribution status in the detection areas in real time. The area frame flashes red when there is an alarm in the area.

Figure 6-121 Live view of crowd distribution



- Right-click on the live video, and then select **Crowd Distribution Map > PIP**. A blue section is displayed, and it shows the crowd distribution status inside the current view.
- Right-click on the live video, and then select **Crowd Distribution Map > Global** to switch to the distribution view. The view indicates crowd density and people heads in different colors.

7 General Operations

This chapter introduces general operations such as live view, playback, alarm, AI functions, and IVS.

7.1 Live and Monitor

After you have logged in, the **LIVE** interface is displayed. See Figure 7-1 and Table 7-1.




Move the mouse pointer to the middle of video window and left column.  is displayed. Click the icon to hide the left column. See Figure 7-2.

Figure 7-1 Live (1)

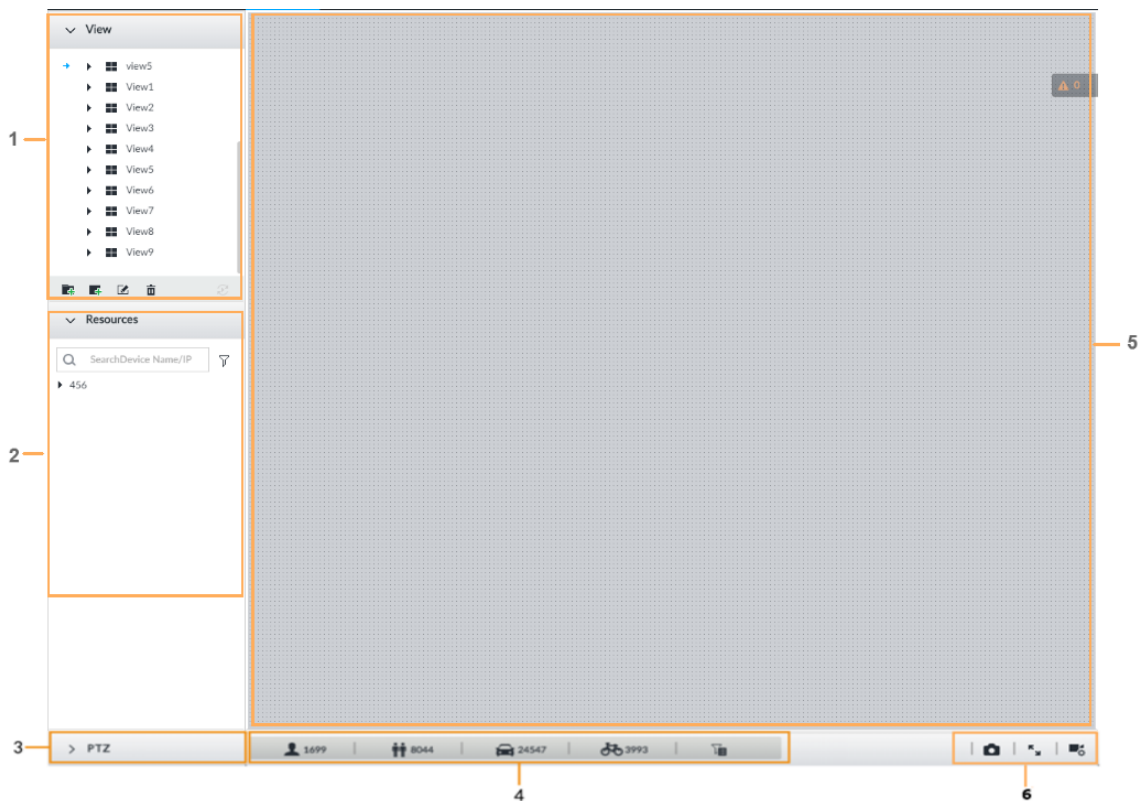


Figure 7-2 Live (2)

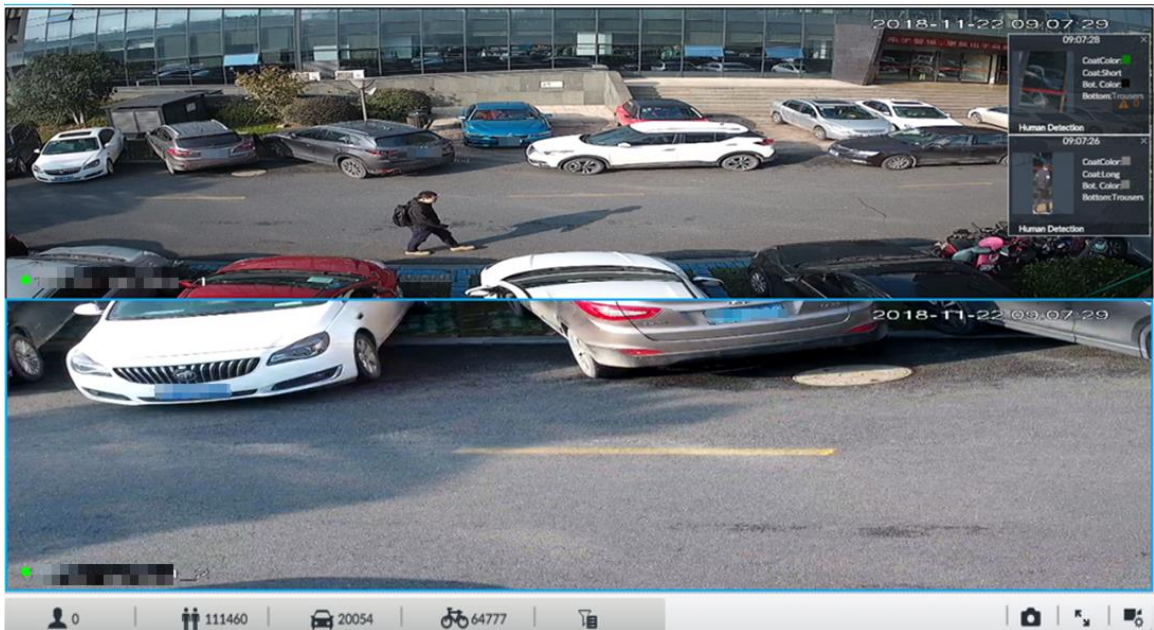





Table 7-1 Live interface description

No.	Description
1	View zone. Displays the created view and view group. See "7.1.1 View Management" for detailed information.
2	Resource pool. Displays the added remote device list.
3	PTZ zone. It is to control the PTZ. See "7.1.3 PTZ" for detailed information.
4	Smart preview icons. View face statistics, person statistics, IVS statistics and AI display.
5	Video play window. See "7.1.1.3 View" window for detailed information.
6	<ul style="list-style-type: none"> Click  to take snapshot. Click  for full-screen view. Click  to go to the VIDEO RECORDING interface for recording configuration. For details, see "8.10 Storage Management."

7.1.1 View Management

View is composed of video images of several remote devices. Go to the view panel at the top left corner of the **LIVE** interface to view or call the view. See Figure 7-3.


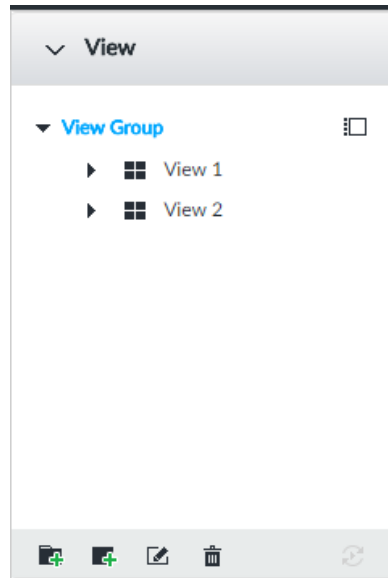
- System has created views group by default. Create view or view group under the View.
- Double-click the view or drag the view to the play panel on the right side. Device begins playing the real-time video from the remote device.
- Click  to select views and its sub-node.

Figure 7-3 View



7.1.1.1 View Group


View group is a group of views. The view group allows you to categorize and manage view. It is easy for you to search and find the view. Create view or view group under the View.



- Device supports maximum 100 view groups.
- The views hierarchy shall not be more than 2. For example, after you create View Group 1 under View, you can create a sub-level View Group 2 under View Group 1. However, you cannot create sub-level group under View Group 2.

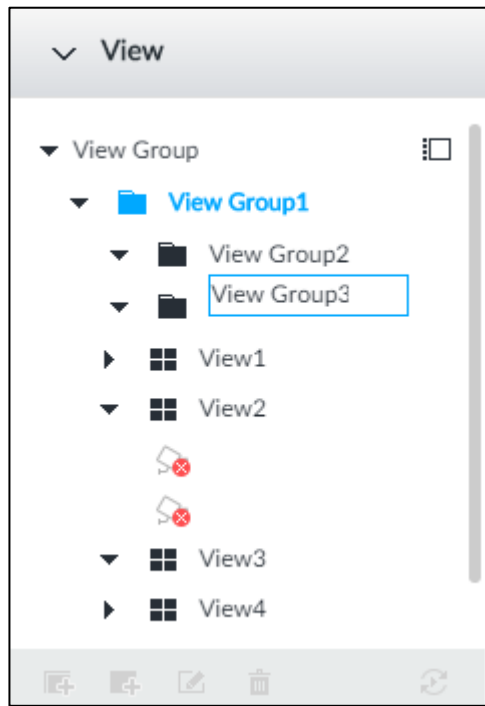
Create view group

Step 1 Follow the steps listed below to create a view group.

- Click **View Group** or a created view group, and then click .
- Right-click **View Group** or a created view group, and then select **Add View Group**.

System creates one view group. See Figure 7-4.

Figure 7-4 Create view group



Step 2 Set view group name.

- The view group name ranges from 1 to 64 characters. It can contain English letters, numbers and special characters.
- View group is to classify or category different view groups. We recommend the view group name shall be easy to recognize.

Step 3 Click any black space on the interface.

Device pops up successfully operated.

Operation

After creating view group, view group can be renamed or deleted. See Table 7-2 for detailed information.

Table 7-2 View group




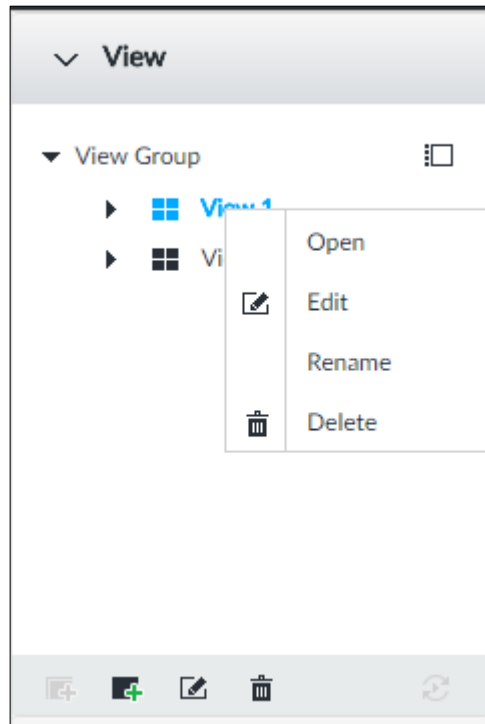
Name	Operation
Rename view group	<ul style="list-style-type: none"> • Select a view group and then click . Set view group name and click any spare panel. • Right-click view group and select Rename. See Figure 7-5. Set view group name and click any spare panel.
Delete View group	<p></p> <p>Once you delete view group, all views under current view group will be deleted at the same time. Please be careful!</p> <ul style="list-style-type: none"> • Select view group and click . • Right-click view group and then select Delete.

Figure 7-5 Rename



7.1.1.2 View

View is a video component of several remote devices. You can drag several remote devices to the same view and when view function is enabled, you can view the real-time video from several remote devices at the same time.

7.1.1.2.1 Creating View

Create view is to add several associated remote devices to the same View. It is easy to view the real-time video from several remote devices at the same time.

Preparation

Remote device has been added. See "5.4.2 Adding Remote Device" for detailed information.

Create View

Step 1 Follow the steps listed below to create view.


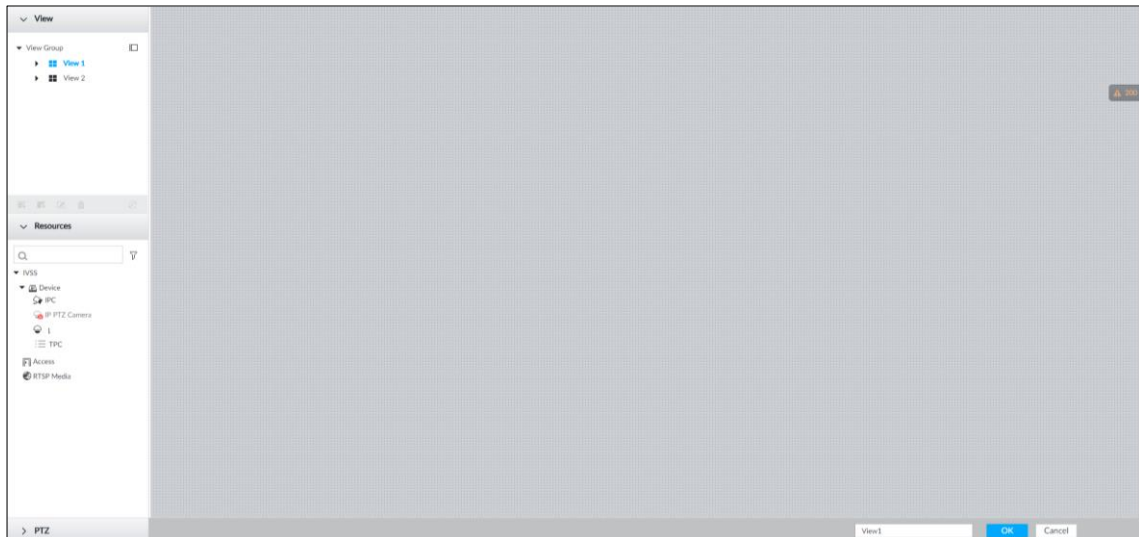

- Select a view group and then click , select **Add view**.
 - Right-click a view group, select **Add view**.
- The **Edit** interface is displayed. See Figure 7-6.

Figure 7-6 Edit view (1)



Step 2 Double-click a remote device in resource pool, or drag the remote device to the right panel.

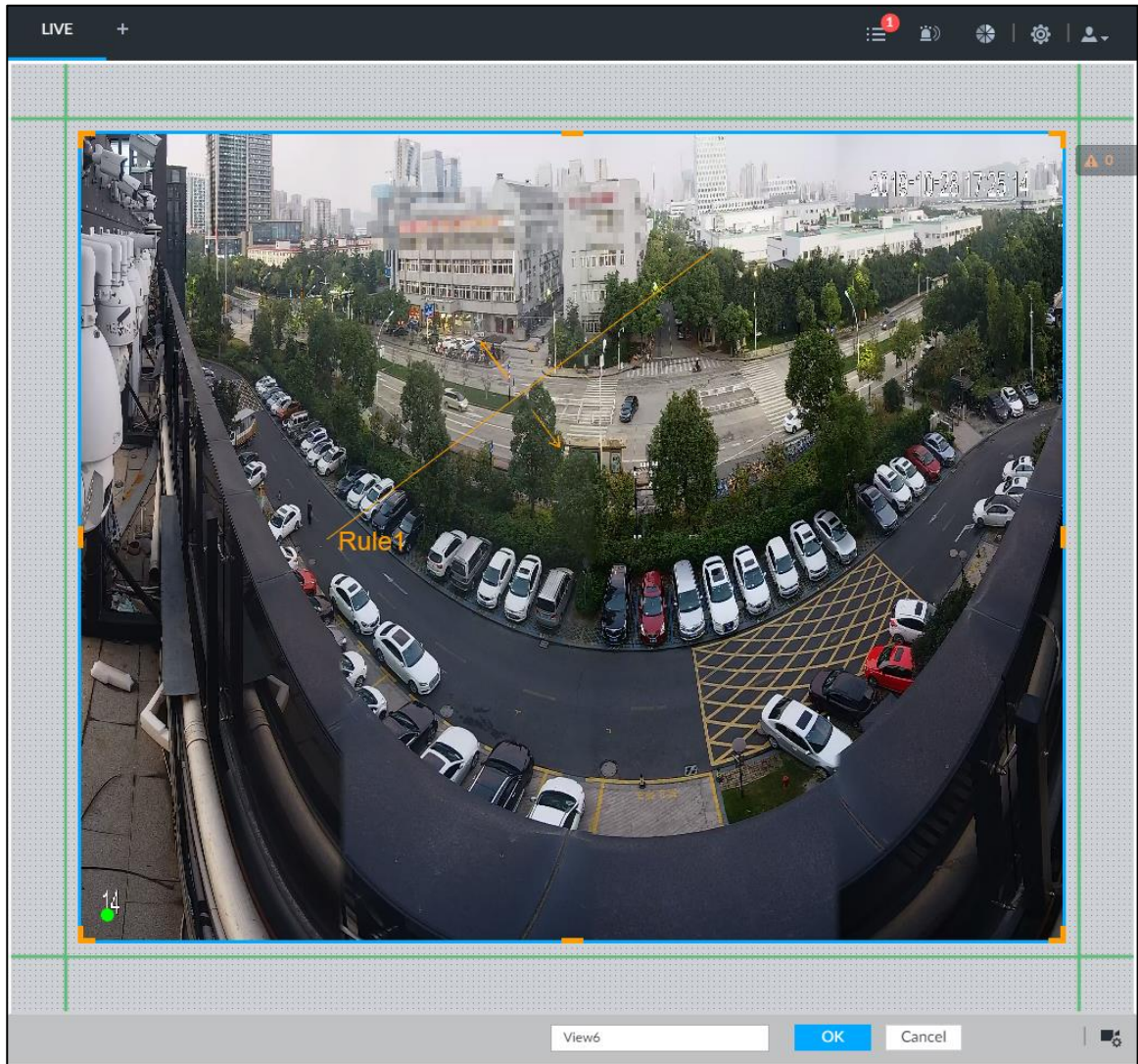
After one remote device is added, layout grid is displayed. See Figure 7-7.

- Each layout grid supports one remote device. If you want to add several remote devices, drag the rest remote device to other idle layout grid.
- If the layout grid has added the remote device, drag another remote device to current grid is to replace the original one.
- Move the mouse pointer to the orange panel (such as ) of the view window, click the view window and then drag after you see the arrow icon. It is to adjust view window size.



- Device automatically creates the view grids amount according to the selected remote device amount. Device supports maximum 36 view windows.
- The view window fills in the whole layout grid by default. Right-click to select **Original Scale > ON**, and turn on the **Original Scale**. The device automatically adjusts view window size according to resolution of remote device.
- When adjusting view window position, drag the view window to the layout grid of the green background color. You cannot drag the view window to the grid of red background color.

Figure 7-7 Edit view (2)



Step 3 Set view name.

The view name ranges from 1 to 64 characters. It can contain English letters, number and special character.

Step 4 Click **OK** to save the configuration.

Device pops up a prompt of **Successfully operated**.

Operation

After creating view, view be edited, enabled, renamed or deleted. See Table 7-3 for detailed information.

Table 7-3 View

Name	Operation
Edit View	Edit remote device in the view, window layout and view name. See "7.1.1.2.2 Editing View" for detailed information.
Enable view	After enabling view, view real-time image of remote device in the view. See "7.1.1.2.3 Enabling view" for detailed information.





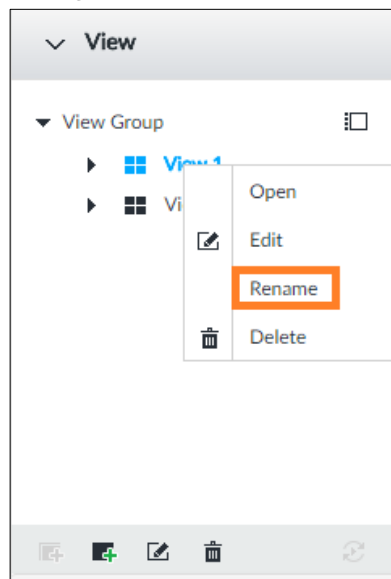
Name	Operation
Rename view	<ul style="list-style-type: none"> • Select a view group and then click . Set view group name and click any spare panel. • Right-click view and select Rename. See Figure 7-8. Set view name and click any spare panel.
Delete view	<ul style="list-style-type: none"> • Delete: Select a view and then click , or right-click view and then select Delete. • Batch delete: Click , select views you want to delete and then click .

Figure 7-8 Menu



7.1.1.2.2 Editing View

In edit view mode, you can perform the following functions:

- Add, or delete the remote device on the view.
- Adjust the view grid display.
- Modify view name.



Step 1 Right-click a view and then select **Edit**.

The **Edit** interface is displayed. See Figure 7-9.

Figure 7-9 Edit view



Step 2 Edit view as you require.

- Add remote device: Double-click remote device in the resource pool, or drag the remote device to the free layout grid on the right panel.
- Delete remote device: Move the mouse to window on the right, and click  at the top right corner.
- Move window position: Select and hold on a view window, move it to the proper position and release mouse.
- Change window position: Select and hold on one view window and then drag to another view window.
- Change window size: Move your mouse to the orange panel on the window (such as ). Hold and drag the view window after you see the arrow icon.
- Modify view name: Set view name on .



When adjusting view window position, drag the view window to the layout grid of the green background color. You cannot drag the view window to the grid of red background color.

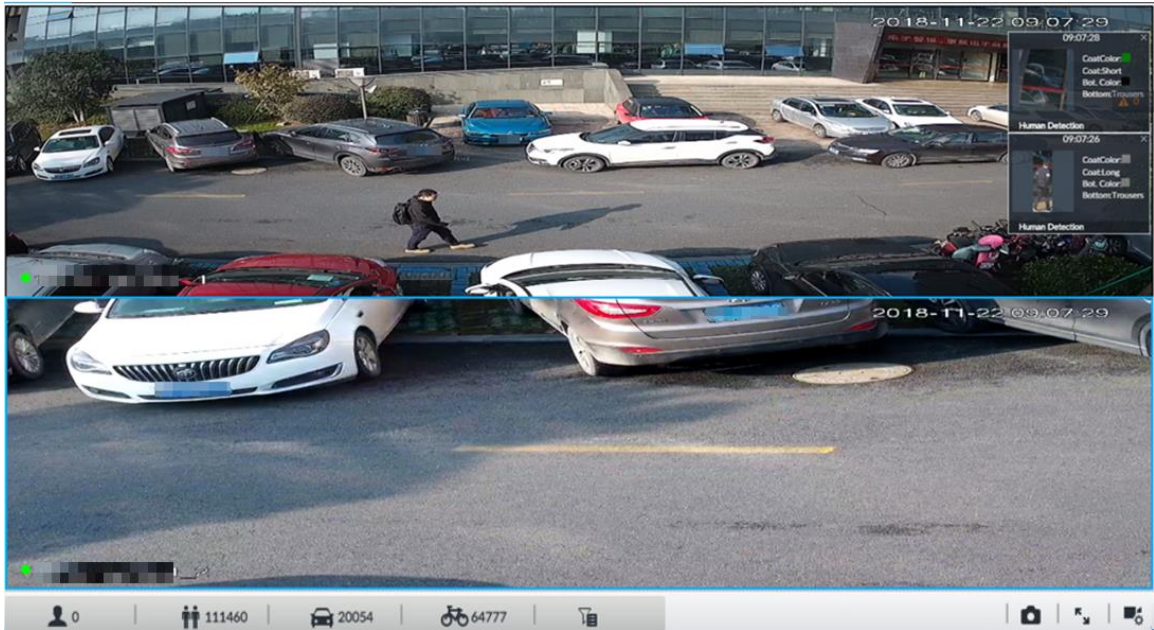
Step 3 Click **OK** to save the configuration.

Device pops up successfully operated.

7.1.1.2.3 Enabling view

Right-click the view and select **Open**, or double-click view. The view window is displayed. See Figure 7-10.

Figure 7-10 View window






When enabling the view, you can change video position, zoom video window. See Table 7-4 for detailed information.



- When adjusting view window position, drag the view window to the layout grid of the green background color. You cannot drag the view window to the grid of red background color.
- Move the mouse to view window. Window task column is displayed to snapshot, enable record and turn off view window. See "7.1.1.3.1 Task Column" for detailed information.
- Right-click view window, you can switch bit streams, set digital zoom. See "7.1.1.3.2 Shortcut Menu" for detailed information.

Table 7-4 View function

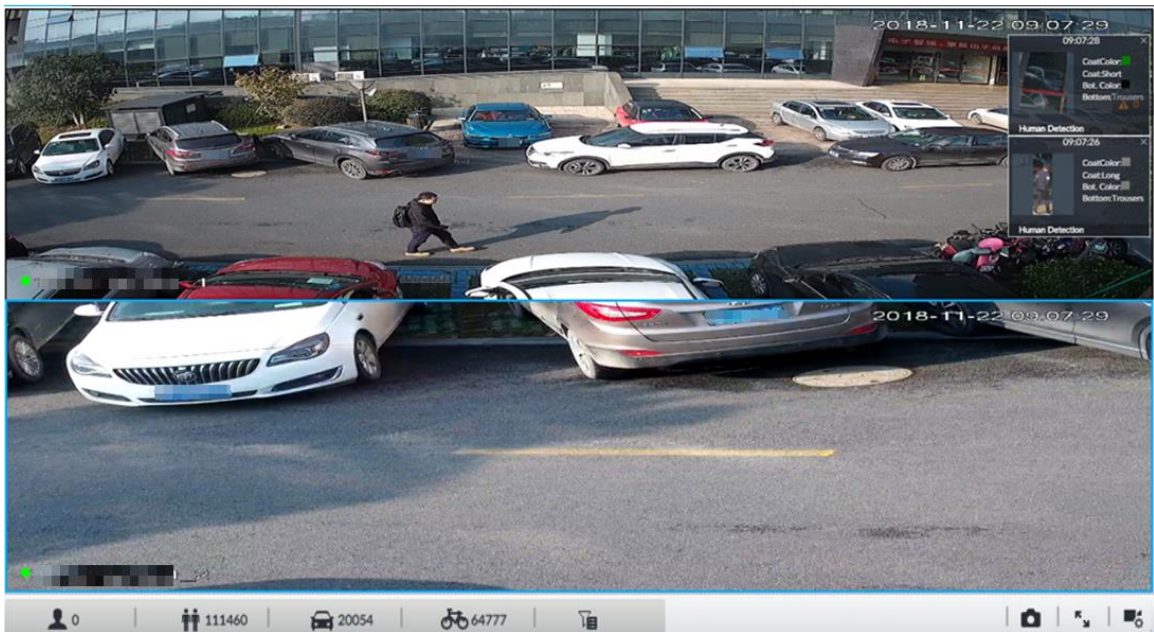
Name	Description
Exchange window position	<p>Press one view window and drag it to another view window to exchange these view window position.</p>  <p>The exchanging window position operation is valid only once. Disable and then enable view again, the view window restores original position. If you want to change view window position permanently, go to the view edit mode to set. See "7.1.1.2.2 Editing View" for detailed information.</p>
Zoom in video window	<ul style="list-style-type: none"> • Once current view window amount is too much (more than 9), click one view window, device displays current view window at the center of the window in the zoom in mode. Click any other blank position, you can view window restores original size. • Double-click a view window, device displays view window at one window. Double-click view window again or click any blank position, the view window restores original size.

Name	Description
Add view window	<p>In the resource pool, double-click the remote device or drag the remote device to the right panel, you can add remote device to current view.</p> <p>Drag the remote device to the view window to replace the original remote device.</p>  <p>The modified view layout is valid only for once if you do not click OK button.</p> <p>Close and enable view again, the view layout restores original layout.</p>
Close view window	<p>Move the mouse to one view window, click  to close the view window.</p> <p>Close view window, device automatically adjusts view layout according to the rest remote device amount and play panel free space.</p>

7.1.1.3 View Window

Right-click the view, select **Open**, or double-click view. The view window is displayed. See Figure 7-11.

Figure 7-11 View window







7.1.1.3.1 Task Column



Move the mouse to view window. The icons are displayed. See Figure 7-12. For details, see Table 7-5.

Figure 7-12 View window



Table 7-5 Window task column

Name	Description
Open Manual Video Recording	<p>Click  to start recording manually. Now the icon becomes . Click  to stop recording.</p> <p>System stops recording according to the manual record length settings if you do not click  again to stop. See "8.2.2.3.5 Storage" for detailed information.</p> <p>At different interfaces, recording storage path varies.</p> <ul style="list-style-type: none"> ● Local Configurations <ul style="list-style-type: none"> ◇ When USB storage device is connected, recordings are saved in USB storage device. ◇ Otherwise, the recordings are saved in the device. Query or export manual recording by playback control. See "7.2.1 Playing Back Recorded Video" for detailed information. ● Operate PCAPP. Default storage path of recording is C:/Program Files (x86)/iVSS/video. Set storage path. See "8.2.2.3.5 Storage" for detailed information.

Name	Description
Snapshot	<p>Click  to snapshot.</p> <p>At different interfaces, snapshot storage path varies.</p> <ul style="list-style-type: none"> ● Local Configurations <ul style="list-style-type: none"> ◇ When USB storage device is connected, snapshots are saved in USB storage device. ◇ Otherwise, the snapshots are saved in the device. Query or export the snapshots by playback control. See "7.2.3 Playing Back Snapshots" for detailed information. ● Operate PCAPP. Default storage path of snapshot is C:/Program Files (x86)/iVSS/pictures. Set storage path. See "8.2.2.3.5 Storage" for detailed information.
Search by image	Take snapshots of face or human during live view, and use the snapshot to search for similar targets. For details, see "7.1.1.3.4 Sear by Image."
Close view window	Click  to close view window.

7.1.1.3.2 Shortcut Menu

Right-click the view window. The shortcut menu is displayed. See Figure 7-13. For details, see Table 7-6.

Figure 7-13 Shortcut menu

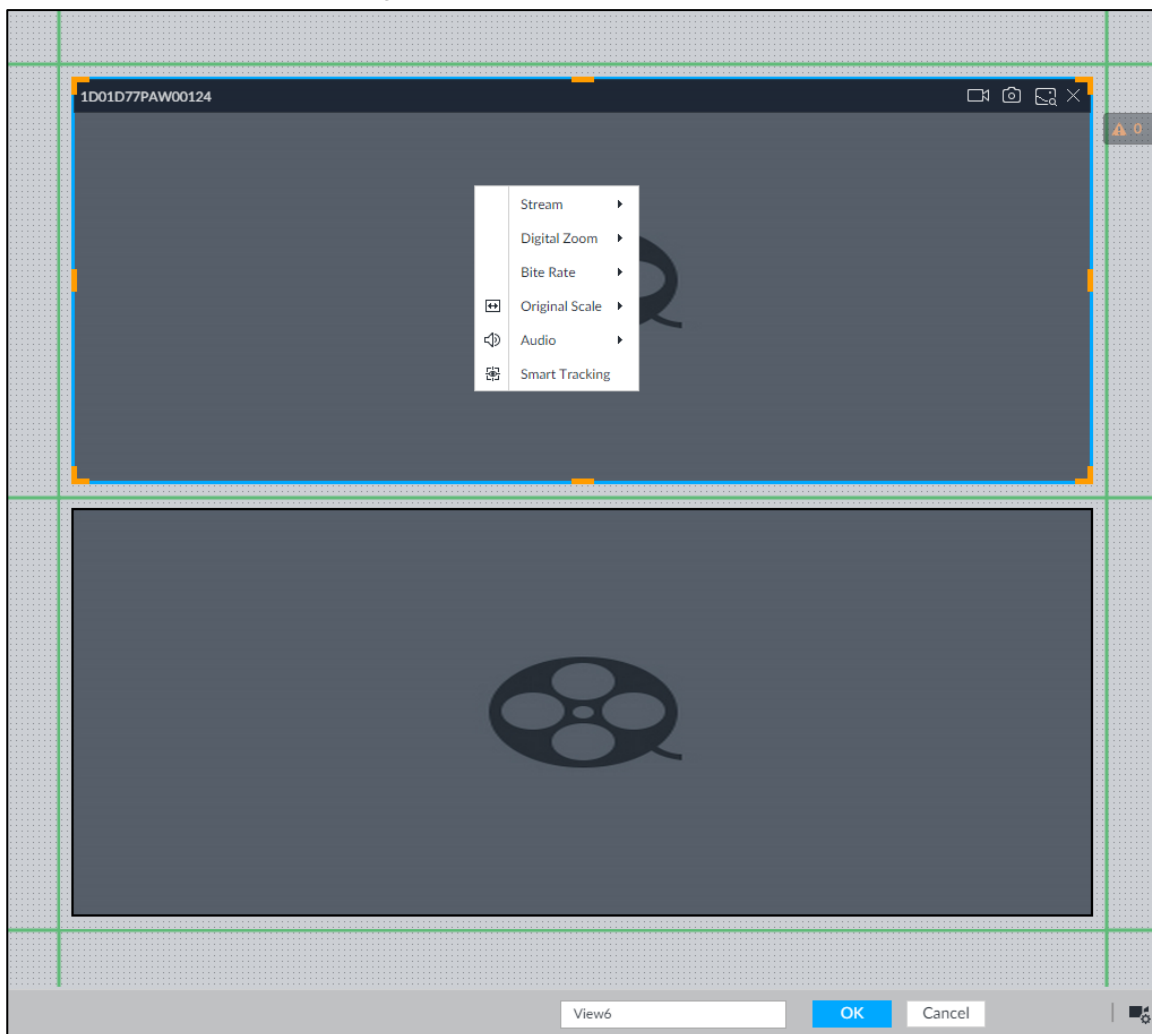


Table 7-6 Shortcut menu



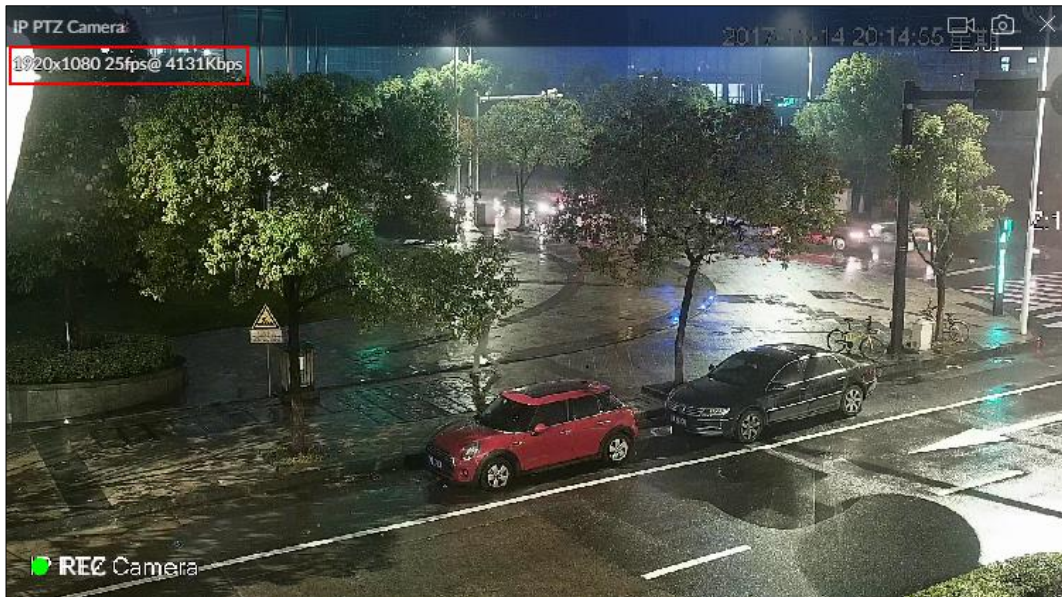
Parameters	Description
Stream	Set current window stream. It includes main stream/sub stream 1/sub stream 2.
Digital zoom	Set digital zoom. Zoom in one part of live image to view details. See "7.1.1.3.3 Digital Zoom" for detailed information.
Bit rate	Displays real-time bit rate on the window or not. See Figure 7-14.
Original Scale	Set video window scale. <ul style="list-style-type: none"> ON: System automatically adjusts video window scale according to the resolution. OFF: System automatically adjusts video window scale according to the remote device amount and the free space on the playback panel.
Audio	Set audio output. It includes audio 1, audio 2, mixing and off.
Fisheye Dewarp	Set instalaltion methods and display modes of fisheye cameras.  This function is only available on fisheye camera.
Smart tracking	Intelligently track targets. For details, see "7.1.1.3.6 Smart Tracking."  This function is only available on the multi-sensor panoramic camera + PTZ camera.

Figure 7-14 View window



7.1.1.3.3 Digital Zoom

The digital zoom function allows you to zoom in a specified zone to view the video details.

After enabling view, right-click **Digital Zoom > ON**. Select a zone in view window, and the selected zone will be zoomed in. See Figure 7-15.

- In zoom in status, press any position on the video window and then drag, you can view the zoom in effect of other zones.
- Select a zone you want to zoom in on the video window again, system zooms in the zone at the larger rate.
- Right-click mouse and then select **Digital Zoom > OFF** to cancel zoom in effect. The video restores original effect.

Figure 7-15 Digital zoom:



7.1.1.3.4 Sear by Image

Draw a frame on the video to select an image than contains targets, and then use the images to search for similar faces or human bodies.


Step 1 Click  at the upper-right corner of the video.

The following interface is displayed. See Figure 7-16.

Figure 7-16 Search by image



Step 2 Draw a frame on the video to select an image than contains target faces or humans.

- Point to the frame, and then you can move its position.
- Drag  to adjust the size.

Step 3 Click **Search by Picture**.

You are prompted to select a type of target.

Step 4 Select a target type.

Step 5 Click **OK**. The system starts searching all the cameras for records within a week.














Other operations

In the search result interface, click a piece of record, the following icons are displayed. See Figure 7-17. For details, see Table 7-7.

Figure 7-17 Icons



Table 7-7 Description

Icon	Operation
	<ul style="list-style-type: none"> Select one by one: Click the panel or move the mouse pointer onto the panel, and then click  to select the panel.  means it is selected. Batch select: Check All to select all panels on the interface.
	<p>Click  or double-click the panel, the system starts to play back the recorded videos (about 10 s).</p>
	<p>Click  to add the image to the face database. See "6.3.3.2.3 Adding from Detection Snapshots" for detailed information.</p>
	<p>Click  or select the panel and click  to export images, videos and Excel to designated storage path.</p> <p></p> <p>After setting alarm linkage snapshot, during exporting images, the system exports detected images and panoramic images at the time of snapshot.</p>
	<p>Click , and then the system automatically searches for the records of the most similar faces.</p>

7.1.1.3.5 Fisheye Dewarp

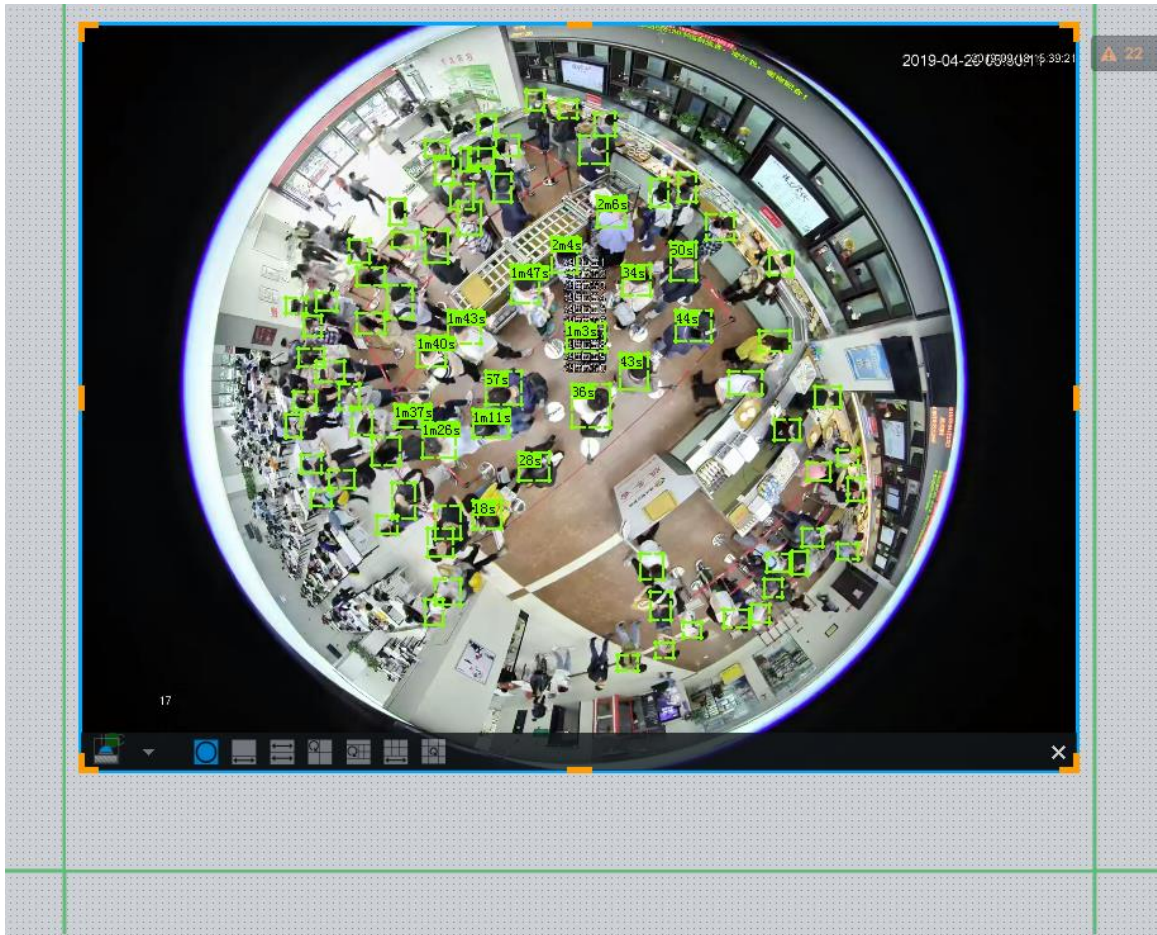
Set the installation method and display mode of fisheye cameras.

- Installation method: Select the installation method according to the actual situation.
- Display mode: Select the display mode of live view.




Step 1 Right-click on the live video, and then select **Fisheye Dewarp**.

The fisheye dewarp interface is displayed. See Figure 7-18.

Figure 7-18 Fisheye dewarp














Step 2 Select an installation method.

- Click  to select ceiling mount.
- Click  to select wall mount.
- Click  to select ground mount.

Step 3 Select a display mode. See Table 7-8.

Table 7-8 Display mode

Installation Method	Display Mode	Description
Ceiling/wall/ground mount		The original fisheye image.
Ceiling/ground mount	 1P+1	Corrected 360°panoramic image + section images.
	 2P	2 corrected 180°images, which consist the 360° panoramic image.
	 1+3	Original image + 3 section images.
	 1+4	Original image + 4 section images.

Installation Method	Display Mode	Description
	 1P+6	Corrected 360°panoramic image + section images.
	 1+8	Original image + 8 section images.
Wall mount	 1P	Corrected 180° image from left to right.
	 1P+3	Corrected 180° image + 3 section images.
	 1P+4	Corrected 180° image + 4 section images.
	 1P+8	Corrected 180° image + 8 section images.

Step 4 Click **OK**.

7.1.1.3.6 Smart Tracking

Track targets manually or automatically. This function is only available on the multi-sensor panoramic camera + PTZ camera.

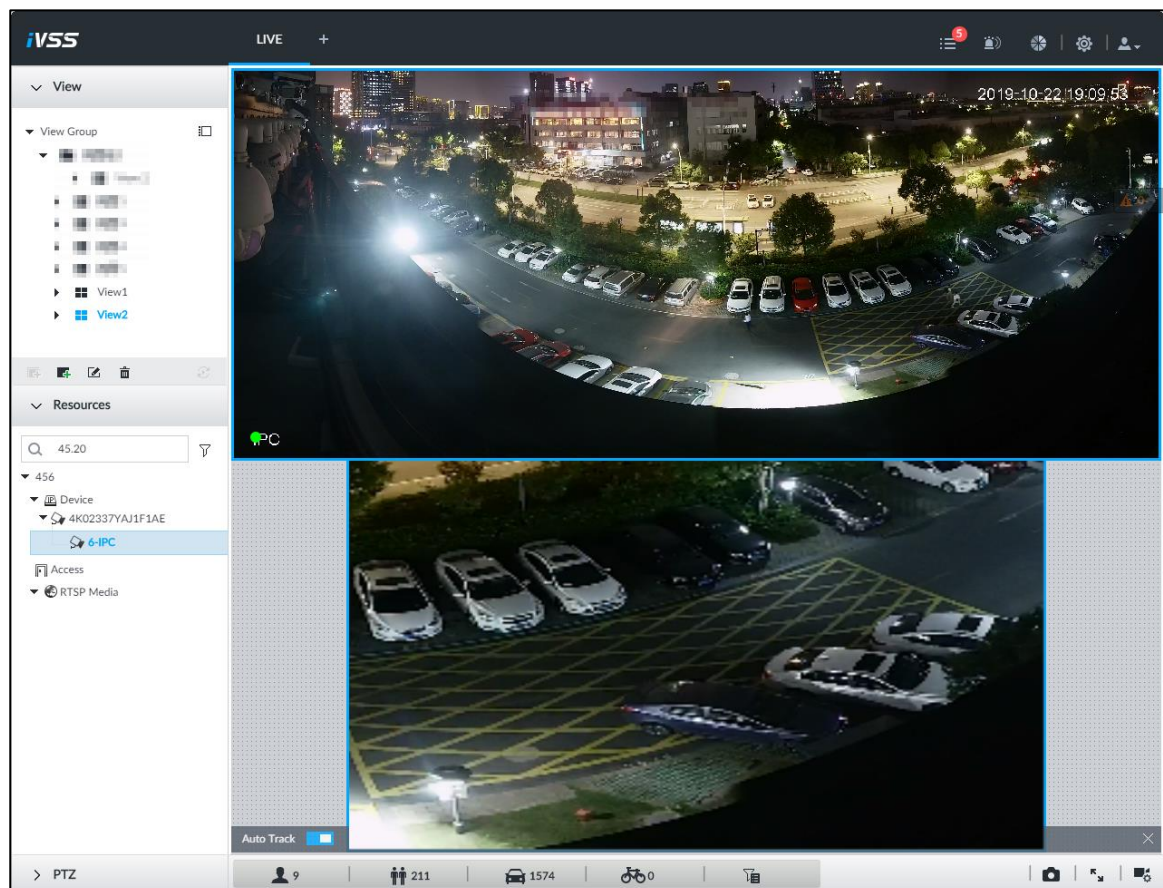


Make sure that the linked tracking function has been enabled.

Step 1 Right-click on the live video, and then select **Smart Tracking > ON**.

The **Smart Tracking** interface is displayed. See Figure 7-19.

Figure 7-19 Smart tracking



Step 2 Select the tracking method.

- Manual positioning: Click a spot or select a zone on the bullet camera video, and then the PTZ camera will automatically rotate there and zoom in.
- Manual tracking: Click or select a target on the bullet camera video, and then the PTZ camera automatically rotates and tracks it.
- Automatic tracking: The tracking action is automatically triggered by alarms in accordance with the pre-defined rules.



For automatic tracking, make sure that you have set intrusion detection or tripwire rules for the camera. For details, see "6.6.2 Configuring IVS."

7.1.1.3.7 Thermal

On the **LIVE** interface, a thermal camera has 2 channels: Visible light channel and thermal channel.

Select the thermal channel, point to any position on the live video, and then you can view the real-time temperature of the position. See Figure 7-20.

Figure 7-20 Thermal



7.1.2 Resources Pool

The resource pool displays the added remote device list. The system automatically divides into groups according to device type. See Figure 7-21. See Table 7-9 for detailed information.

Figure 7-21 Resources pool

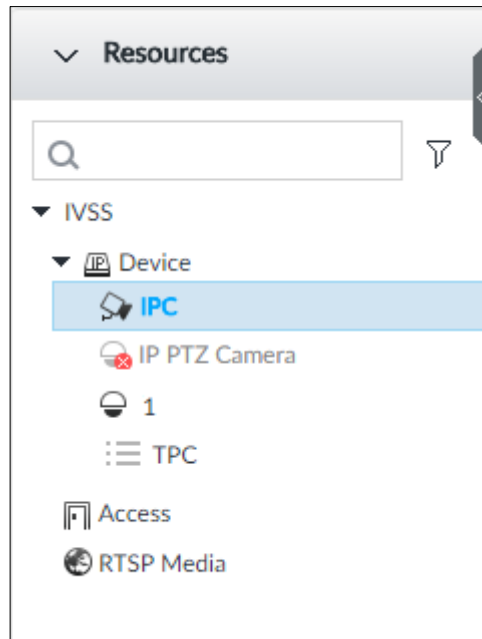









Table 7-9 Resources pool description

Operation	Description
Search device	<p>Input key words at , device displays the corresponding remote devices.</p> <p> Support fuzzy search.</p>
Filter device	<p>Click  and then select all, online, offline. It is to filter the disqualified remote device.</p>
View device status	<p>Display remote device status on the resources pool.</p> <ul style="list-style-type: none"> • If the remote device name and icon is black, it means the remote device is online. For example,  IP PTZ Camera . • If the remote device name and icon is gray, it means the remote device is offline. For example,  IPC . • If there is an icon  before the remote device, it means remote device is abnormal, alarming, and so on. Move the mouse to , to view the detailed information.

Operation	Description
Mouse Operations	<ul style="list-style-type: none"> • Move the mouse to the remote device name, you can view remote device IP address and port number. • On the device list, click one remote device and then press Ctrl, click other remote device, you can select several remote devices at the same time. • On the device list, select one remote device and then press Shift, click other remote device, select current two remote devices and all remote devices listed between them. • Right-click a remote device to connect to disconnect it. • Double-click remote device or drag the remote device to the view window on the right panel, you can enter edit view interface. Edit the view. See "7.1.1.2.2 Editing View" for detailed information.

7.1.3 PTZ

Control the PTZ, you can move the PTZ at all directions, lens zoom in/zoom out, focus control, and so on. In this way, it can display PTZ at all angles from different positions.

On the **LIVE** interface, PTZ is displayed at the lower-left corner. See Figure 7-22. For details, see Table 7-10.



The following figure for reference only. The grey button means current function is null.

Figure 7-22 PTZ

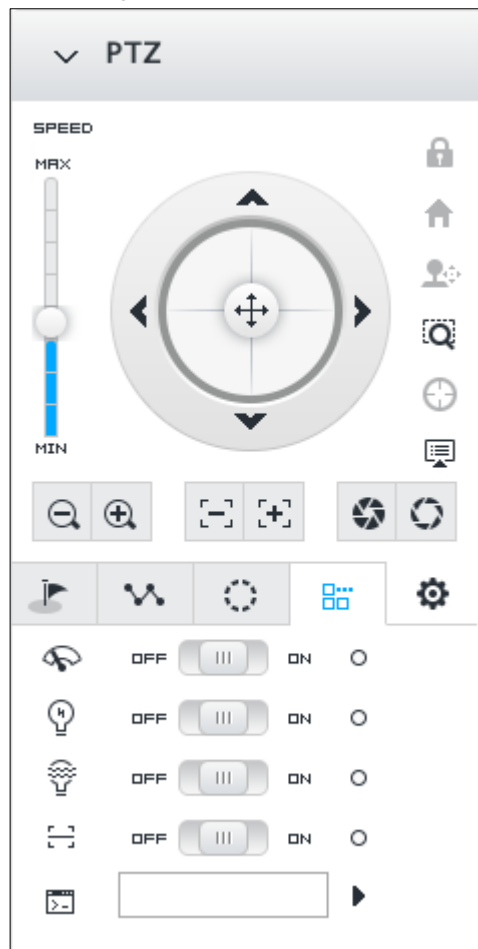




















Table 7-10 PTZ Icons description

Signal Words	Description
 <p>A vertical slider control labeled 'SPEED'. The top is marked 'MAX' and the bottom 'MIN'. A blue bar indicates the current speed level, with a white knob at the top.</p>	<p>Press and hold on , and drag it up and down. Set PTZ speed. The higher the value is, the faster the PTZ speed is.</p>
 <p>A circular control pad with a central crosshair and four outer directional arrows (up, down, left, right).</p>	<p>Control PTZ movement in the following ways.</p> <ul style="list-style-type: none"> • Press and hold on  to control PTZ top/bottom/left/right/top left/top right/lower-left/lower-right direction. • Click , ,  or  to control PTZ top/bottom/left/right direction.
 <p>An icon of a camera with a 3D coordinate system overlaid on it.</p>	<p>Click to enable 3D positioning function.</p>
 <p>An icon of a speech bubble with a list of items inside.</p>	<p>Click to enter PTZ menu mode. See "7.1.3.2 PTZ Menu Settings" for detailed information.</p>
 <p>Two square buttons: one with a minus sign and a magnifying glass (zoom out), and one with a plus sign and a magnifying glass (zoom in).</p>	<p>Zoom. Click to adjust lens zoom rate of the remote device.</p>
 <p>Two square buttons: one with a minus sign and a square (focus out), and one with a plus sign and a square (focus in).</p>	<p>Focus. Click to adjust lens focus of the remote device.</p>
 <p>Two square buttons: one with an iris icon (iris out) and one with an iris icon (iris in).</p>	<p>Iris. Click it to adjust iris size of the remote device.</p>
 <p>A row of four square buttons: a flag icon (presets), a zigzag icon (cruise), a circular arrow icon (pattern), and a grid icon (menu).</p>	<p>Click to enter PTZ call interface.</p> <p></p> <p>Go to the remote device to set corresponding PTZ function before you call it.</p> <ul style="list-style-type: none"> • Click  to enter preset call interface. See "7.1.3.3.1 Calling Preset" for detailed information. • Click  to enter call cruise interface. See "7.1.3.3.2 Calling Cruise" for detailed information. • Click  to enter call pattern interface. See "7.1.3.3.3 Calling Pattern" for detailed information.


7.1.3.2 PTZ Menu Settings

Enable PTZ menu function, device displays PTZ main menu on the view window. The PTZ main menu includes camera settings, PTZ settings, system management, and so on. Use direction button and confirm button to set the remote device.



PTZ menu function is for remote device that supports PTZ function only.

Step 1 Enable view and then select a remote device on the view.

Step 2 On PTZ panel, click .

The OSD menu is displayed on the screen. See Figure 7-23. For details, see Table 7-11.

Figure 7-23 PTZ menu interface

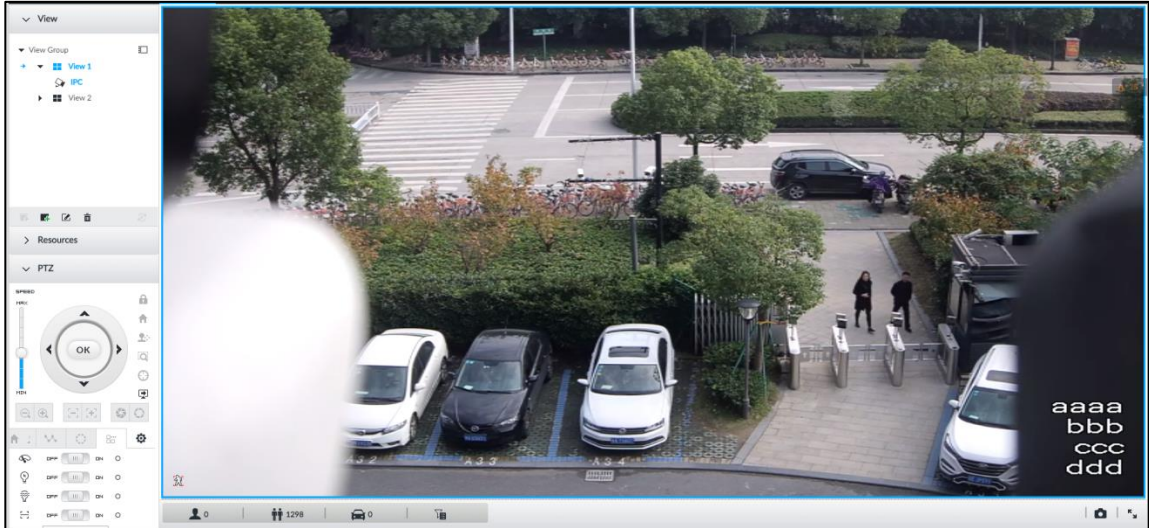











Table 7-11 PTZ menu description

Parameters	Description
Camera	Enter camera interface, you can set remote device image parameters. It includes picture, exposure, backlight, WB, day and night, focus and zoom, defog, default, and so on. (Different series products have different menu items.)
PTZ	Enter PTZ interface, you can set remote device PTZ function. It includes preset, cruise, scan, pattern, rotation, PTZ restart and so on.
System	Enter system interface, you can set remote device PTZ simulator, restore default, manage remote device peripheral device, view remote device software version, PTZ version and so on.
Exit	Exit PTZ menu interface.

Step 3 Set PTZ menu parameters.

Enter PTZ menu interface with PTZ operation icons, and set configuration items.

- Click  or  to select items.
- Click  or  to set parameters.
- Click  to confirm current items.
 - ◇ When there is sub-menu of the item on the main menu, move the mouse to the current item and then click , enter sub-menu interface.
 - ◇ Select **Back** and then click , return to upper-level menu.
 - ◇ Select Exit and then click  to exit PTZ menu mode.

Step 4 Click  to exit PTZ menu mode.

7.1.3.3 Calling PTZ Functions

Control PTZ device to implement corresponding operations.



Different PTZ devices support different PTZ functions. See the actual interface for detailed information.

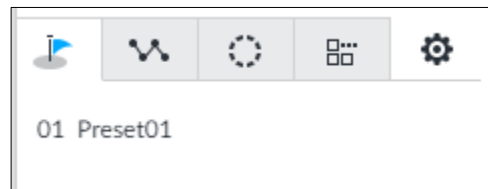
7.1.3.3.1 Calling Presets

Preset function is to save the position information (such as PTZ pan/tilt, focus) to the memory, so that you can quickly call these parameters and adjust the PTZ to the correct position.

Step 1 Click .

The **Preset** interface is displayed. See Figure 7-24.

Figure 7-24 Call preset



Step 2 Move the mouse to the preset name.

The  displays at the right side of the preset name.

Step 3 Click .

PTZ device goes to the corresponding position.

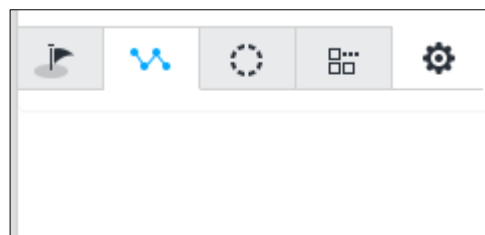
7.1.3.3.2 Calling Cruise

Cruise is to add presets into a routine in a desired order and then set time and stop duration for each position. The dome will begin an auto cruise between these presets.

Step 1 Click .

The call cruise interface is displayed. See Figure 7-25.

Figure 7-25 Call cruise




Step 2 Move the mouse to the cruise name.

The  displays at the right side of the cruise name.

Step 3 Click  .

PTZ device calls cruise path and goes to the presets at the specified order and interval.

Step 4 Click  to stop calling cruise.

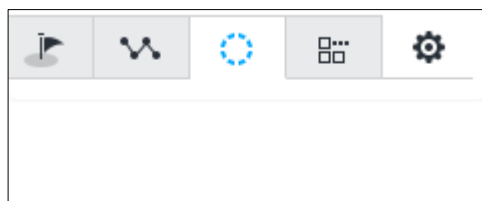
7.1.3.3.3 Calling Patterns

Pattern is to memorize dome operation such as pan, tilt, and zoom to repeat. Start position of record is starting point. You can call it to repeat the previous operation.


Step 1 Click  .


The call pattern interface is displayed. See Figure 7-26.

Figure 7-26 Call pattern




Step 2 Move the mouse to the pattern name.

The  displays at the right side of the pattern name.

Step 3 Click  .

PTZ device calls pattern and move back and forth according to the settings.

Step 4 Click  to stop calling pattern.

7.2 Recorded Files

Search or play back the record file or image on the device. At the same time, you can export record file or image to designated storage path.

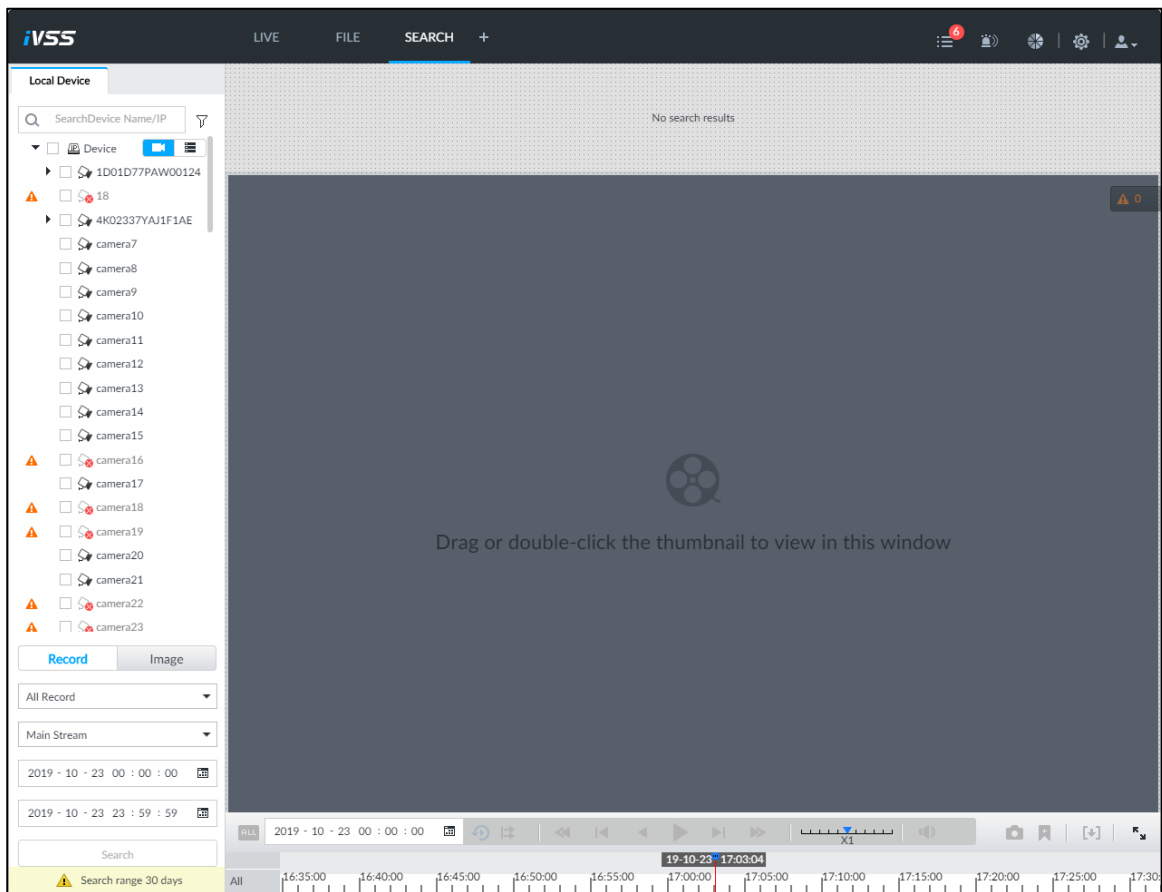
7.2.1 Playing Back Recorded Video

Search and playback record file according to remote device, record type, and record time.

Step 1 On the **LIVE** interface, click  and then select **SEARCH**.


The **SEARCH** interface is displayed. See Figure 7-27.

Figure 7-27 Search



Step 2 Select a remote device, and then click **Record** tab.




Click  to display only channels. Click  to display channels and devices.

Step 3 Select a record type from among All Record, Manual Record, Video Detect, and IO Alarm and Thermal.

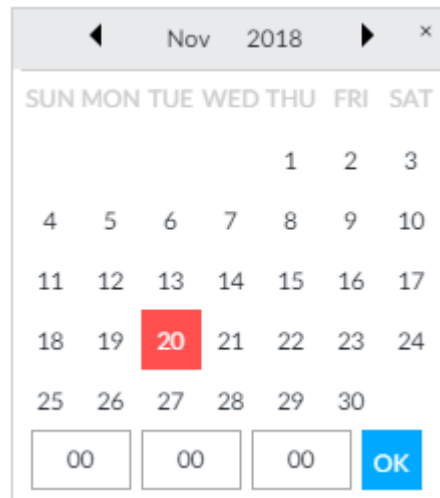
- All record: Search all records.
- Manual record: Search the records that are manually enabled by the user. For manual record, see "7.1.1.3.1 Task Column" for detailed information.
- Video detect: Search the records of video detection. For setting of video detection record, see "8.4.3.1 Video Detect."
- IO alarm: Search local alarm linkage records. For setting of local alarm linkage record, see "8.4.2.4 Configuring Device Alarm."
- Thermal: Search for videos of thermal alarms. For setting of thermal alarm linkage, see "8.4.3.4 Thermal Alarm."

Step 4 Set search time.

- Method 1: Click the date or time on the time column, change time or date value.
- Method 2: Click the date or time on the time column, use the mouse middle button to adjust time or date value.
- Method 3: Click , set date or time on the schedule, click **OK** button. See Figure 7-28.

In the schedule interface, if there is a dot under one date (such as ²⁴), the date has records.

Figure 7-28 Schedule interface



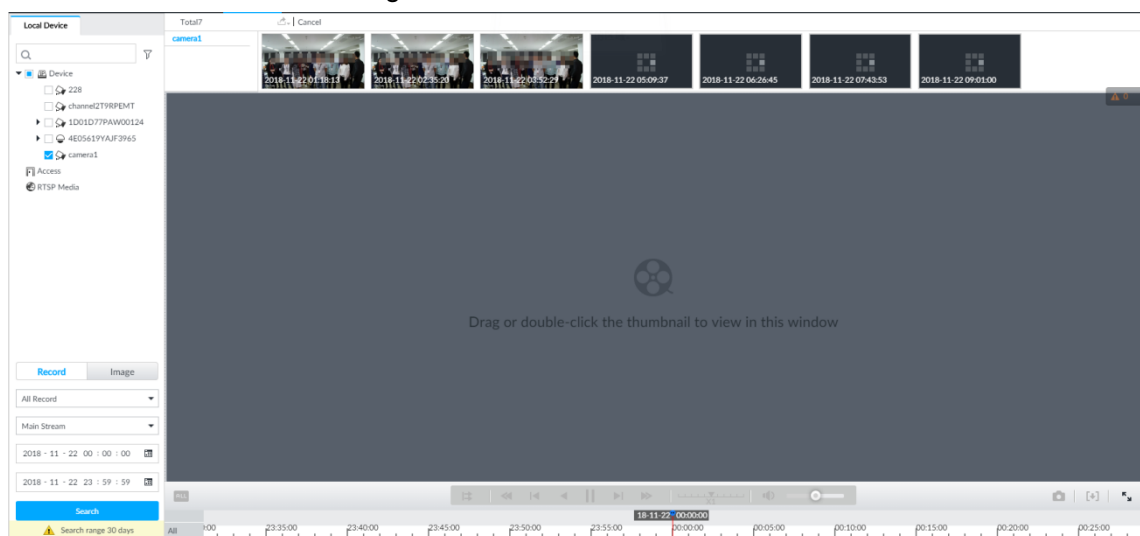
Step 5 Click **Search**.

The record thumbnail is at the top of the remote device, and the time bar displays the record period (green color means there is a record). See Figure 7-29.



- The selected remote device is on the left panel. Click a remote device, and the record file thumbnail is on the right panel.
- Click or to move thumbnail list or hide/display the thumbnail.
- Move the mouse pointer to the thumbnail, you can view remote device name, record start time, and end time of the corresponding record.
- Move the mouse pointer to the thumbnail list. The interface displays . Click the icon to hide the thumbnail list. If the thumbnail list is hidden, click to display the thumbnail list.

Figure 7-29 Search result



Step 6 Drag the thumbnail to the playback window or double-click the thumbnail.

Device begins playing the record. See Figure 7-30. See Table 7-12 for detailed information.



































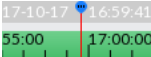
- The playback window amount depends on the thumbnail amount you can drag or select. System supports maximum 16 windows. System automatically adjusts each window size according to the original scale of playback file.
- The thumbnail with  means system is playing record file of current thumbnail.

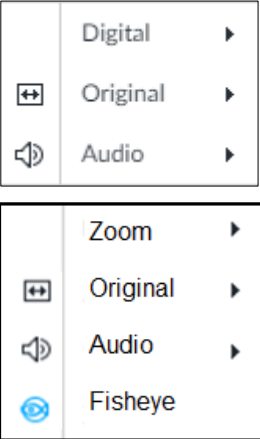


Figure 7-30 Search



Table 7-12 Search icons description

Signal Words	Description
	<p>Click to synchronize playback mode. You can use the playback control icon to control several windows, such as fast forward/backward at the same time.</p> <p>Click  to cancel synchronization operation.</p>
	<p>Set a time period. Click  to start playing the videos in the set time period.</p>
	<p>Play back several record files at the same time. Click the icon to switch to time synchronization mode. All other windows play the video file of the same time of current window.</p> <p>Click  to cancel time synchronization.</p> <p></p> <p>Click , system enables synchronization operation function. If you want to cancel synchronization, click .</p>
	<p>Click to play back video file at slow speed. The slow speed includes $\times 1/2$, $\times 1/4$, $\times 1/8$, and $\times 1/16$. Click the icon once, the playback speed degrades one level.</p>
	<p>Click to switch to frame by frame backward playback.</p> <p></p> <p>It is only valid in pause mode.</p>

Signal Words	Description
	Click to play backward. Now the icon becomes  . Click  to stop backward play.
	Click to start playback. Now the icon becomes  . Click  to pause playback video.
	Click to switch to frame by frame playback.  It is only valid in pause mode.
	Click to play back at fast speed. The fast speed includes $\times 1$, $\times 2$, $\times 4$, $\times 8$, and $\times 16$. Click the icon once, the playback speed upgrades one level.
	Displays playback speed. Drag  to the left or right to playback at fast forward or fast backward.
	Click to capture an image.
	Click this icon to tag the current video.
	Click to obtain one part of record, and save it in designated storage path. See "7.2.2 Clipping Recorded Video" for detailed information.
	Click  to mute. The icon becomes  . Click  to unmute.
	Click to play back at full screen.
-	<p>Time bar. Displays record type and record file period.</p> <ul style="list-style-type: none"> • There are two record file bars on the time bar. The top bar is to display record time of selected window. The bottom bar is to display record time of all selected remote devices. • The time bar adopts color to categorize record type. Green=Regular record. Red=Alarm record. Blank=No record. •  Time scale is to display record file date and time. System automatically adjusts time scale according to the record playback process. • On the time bar, you can: <ul style="list-style-type: none"> ◇ Click the time bar and rotate the mouse wheel button to adjust the time accuracy. ◇ Press the time bar and then drag to the left or right. It is to move the time bar to view the hidden record time. ◇ Drag time scale to adjust start time of record playback. ◇ Click or drag the time scale to position where there is a record, system starts playing from the selected time. ◇ Click or drag the time scale to position where there is no record, system stops playing record.

Signal Words	Description
	<p>Shortcut menu: Right-click mouse on the playback window, you can view the shortcut menu.</p> <ul style="list-style-type: none"> Zoom: It is to zoom in a specified zone and view the details. See "7.1.1.3.3 Digital Zoom" for detailed information. Original scale: Set view window scale. <ul style="list-style-type: none"> ◇ ON: System automatically adjusts video window scale according to the video resolution. ◇ OFF: System automatically adjusts video window scale according to the remote device amount and the free space on the playback panel. Audio: Set audio output. Fisheye: Set the installation method and display mode of fisheye camera. For details, see "7.1.1.3.5 Fisheye Dewarp."
	<p>Select faces or humans on the video to search for similar targets. For details, see "7.1.1.3.4 Sear by Image."</p>
	<p>Move the mouse pointer to the playback window, system pops up task column. Click the icon to close the playback window.</p>

7.2.2 Clipping Recorded Video

Clip one part of the recorded video, and save it in designated storage path.



Connect USB device to the system if you are on the local menu to operate.

Step 1 On the **LIVE** interface, click  and then select **SEARCH**.

The **SEARCH** interface is displayed.

Step 2 See "7.2.1 Playing Back Recorded Video" to play video file.

The video playback interface is displayed. See Figure 7-31.

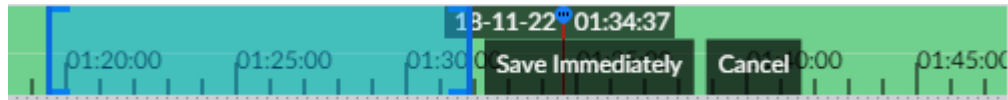
Figure 7-31 Playback



Step 3 Click .

Video clipping frame appears on the time bar. See Figure 7-32.

Figure 7-32 Video clipping frame

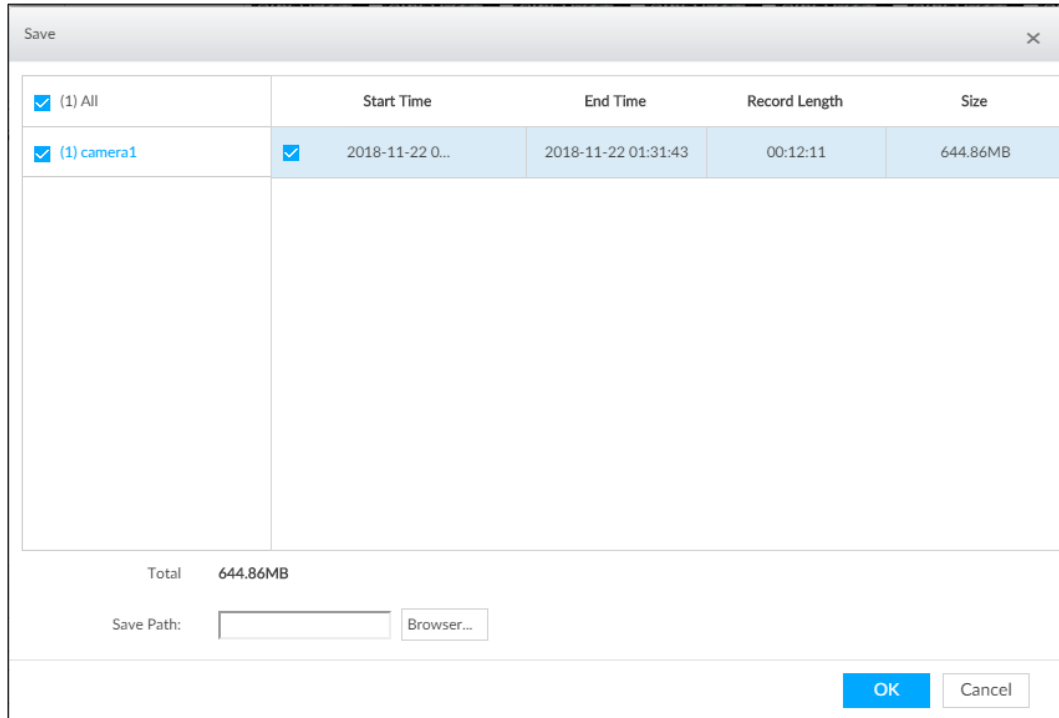


Step 4 Click the record edit column (the blue column on Figure 7-32) and drag to the left or right, to select start time and end time of clipping.

Step 5 Click **Save Immediately**.

The **Save** interface is displayed. See Figure 7-33.

Figure 7-33 Save



Step 6 Click **Browser** to select saving path.

Step 7 Click **OK**.

Save the clipping to designated storage path.

7.2.3 Playing Back Snapshots

Search and play back image according to remote device, image type, and snapshot time.

Step 1 On the **LIVE** interface, click **+** and then select **SEARCH**.

The **SEARCH** interface is displayed.

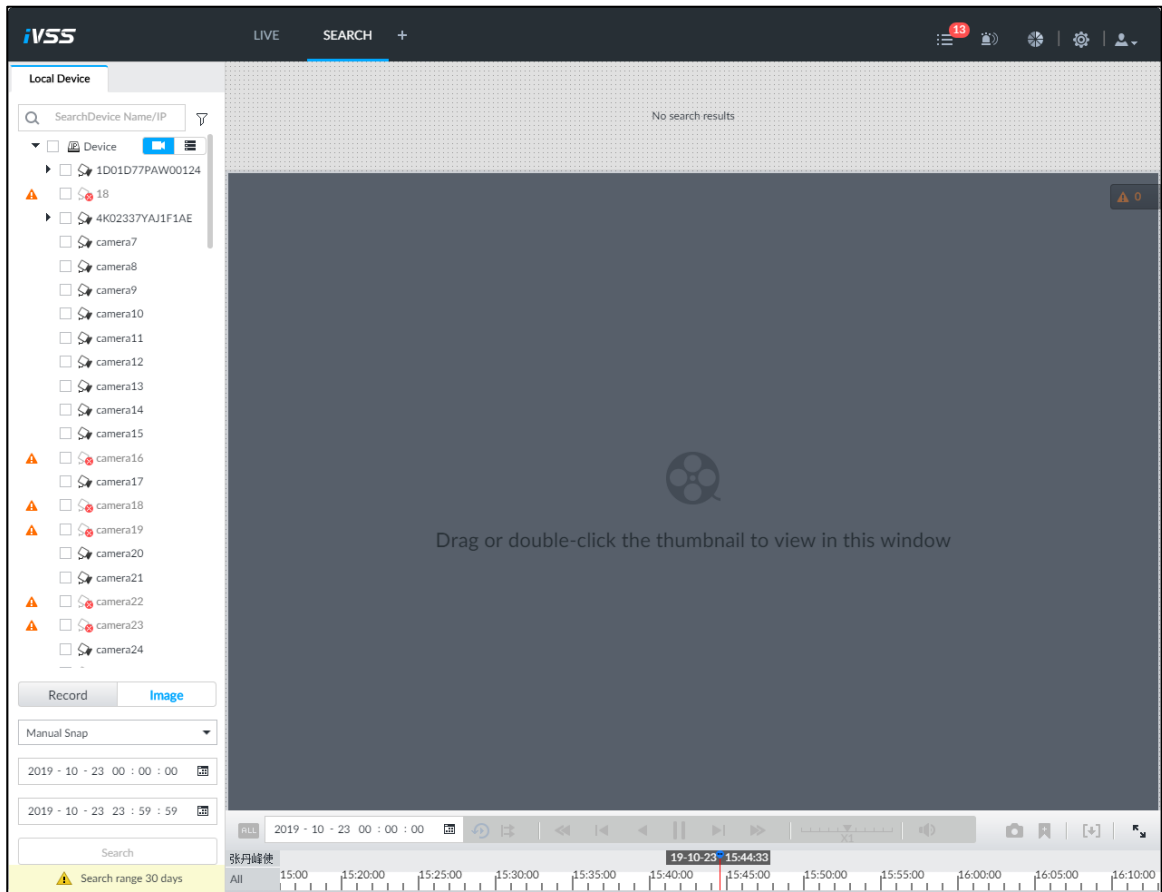
Step 2 Select a remote device, and then click **Image**.

The **SEARCH** interface is displayed. See Figure 7-34.




System supports maximum 1 remote device.

Figure 7-34 Image playback (1)



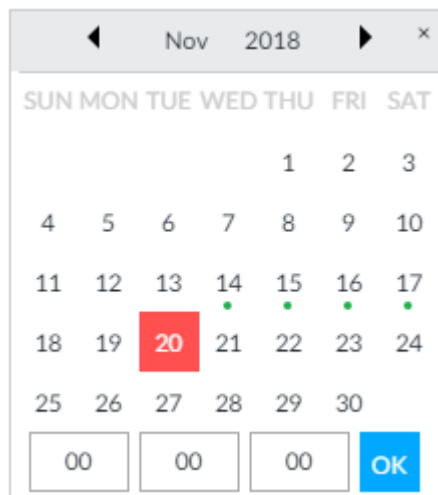
Step 3 Select image type, including manual snap and video detect.

Step 4 Set search time.

- Method 1: Click the date or time on the time column, change time or date value.
- Method 2: Click the date or time on the time column, use the mouse wheel to adjust time or date value.
- Method 3: Click , set date or time on the schedule, click **OK** button. See Figure 7-35.

In the schedule interface, if there is a dot under one date (such as ²⁴), the date has records.

Figure 7-35 Schedule interface







Step 5 Click **Search**.

System displays searched image thumbnail. See Figure 7-36.

Figure 7-36 Image thumbnail

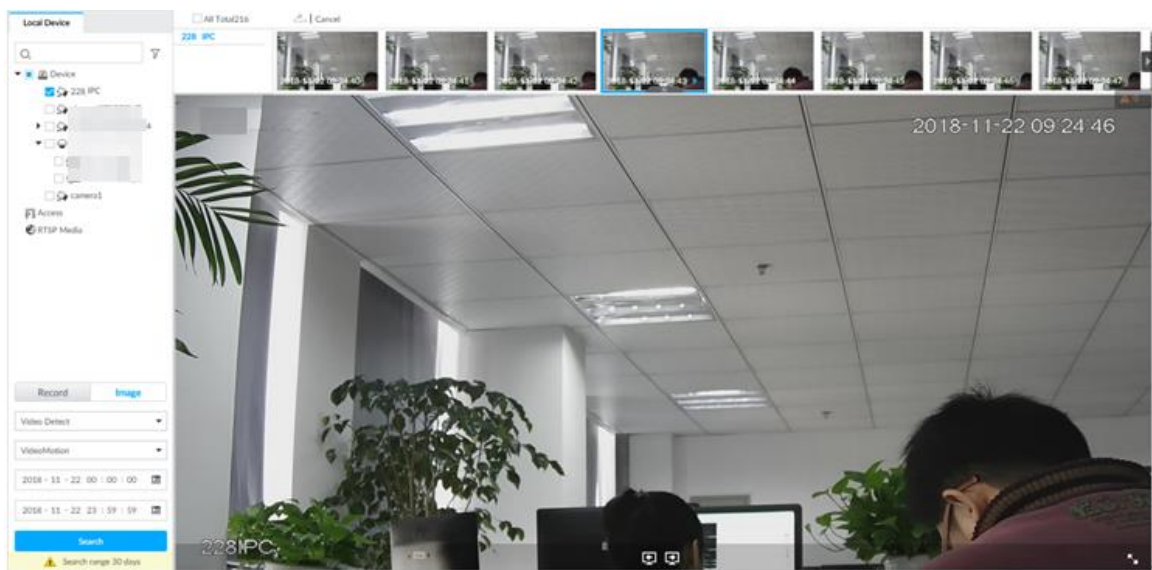


- The selected remote device is on the left panel. Click a remote device, and the image thumbnail is on the right panel.
- Click  or  to move thumbnail list, and display the hidden thumbnail.
- Move the mouse pointer to the thumbnail, you can view remote device name, and snapshot time of the corresponding thumbnail.
- Move the mouse pointer to the thumbnail list. The interface displays . Click the icon to hide the thumbnail list. If the thumbnail list is hidden, click  to display the thumbnail list.

Step 6 Drag the thumbnail to the playback window or double-click the thumbnail.



Device begins playing the image. See Figure 7-37. See Table 7-13 for detailed information.

Figure 7-37 Image playback (2)



Move the mouse pointer to the playback window, you can see the following icons.

Table 7-13 Icons

Icon	Description
	Click to switch to the previous image or the next image.
	Switch to the previous or next image or image group. <ul style="list-style-type: none"> • When playing one image, click the icon to go to the previous image or the next image. • When playing several images at the same time, click the icon to go to the previous group or the next group.

Icon	Description
	Click to display at full screen. Click again to cancel full screen.

7.2.4 Exporting File

Export record file or image to the designated storage path.

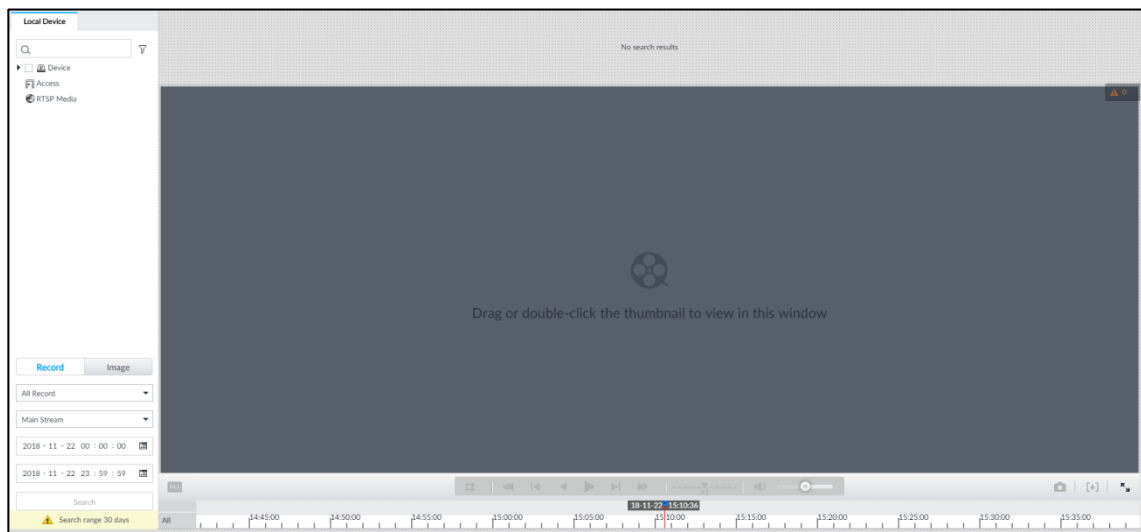


- The default record file mode is .dav and the image file mode is .jpg.
- Connect USB device to the system if you are on the local menu to operate.

Step 1 On the **LIVE** interface, click  and then select **SEARCH**.

The **SEARCH** interface is displayed. See Figure 7-38.

Figure 7-38 Search (1)

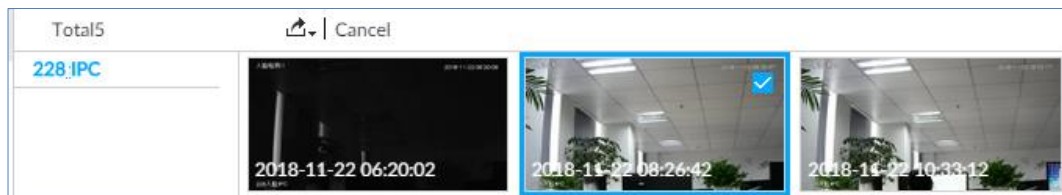


Step 2 Search record file or image.

- 1) Click **Record** or **Image** tab.
- 2) Select a remote device and then set search criteria.
- 3) Click **Query**.

System displays searched record or image thumbnail. See Figure 7-39.

Figure 7-39 Thumbnail



Step 3 Select the record file or image you want to export.

- Move the mouse pointer to the thumbnail and then click to select the thumbnail. means checked.
- Click **Cancel** to cancel all record files or images.

Step 4 Select file storage path.

- 1) Click  and then select **Export record** or **Export image**.

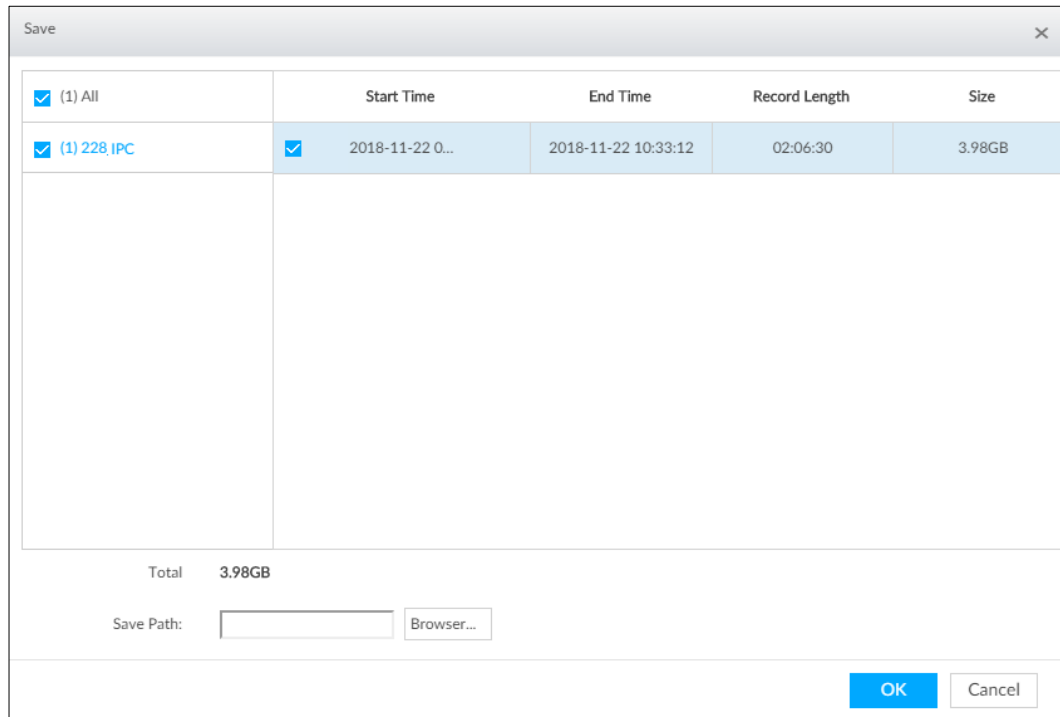


The following steps are to export video file. See the actual interface for detailed information.

- 2) Click **OK**.

The **Save** interface is displayed. See Figure 7-40.

Figure 7-40 Save



- 3) Click **Browser** to select saving path.



For local operation, after you set storage path, the **Save** interface displays the **Format** button. Click the **Format** button to clear all data on the USB storage device. The formatting operation will clear all data. Be cautious.

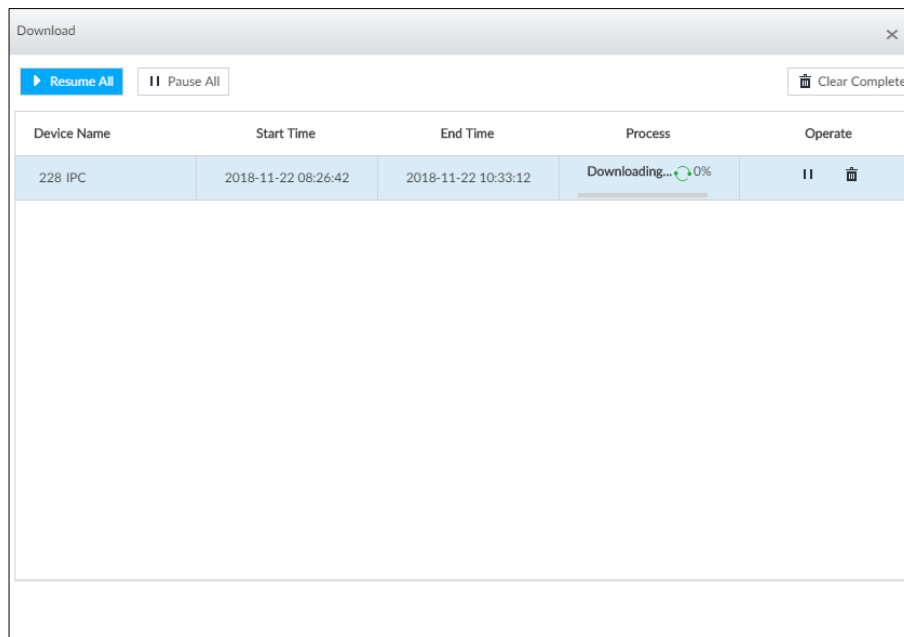
- 4) Click **OK**.




Device goes back to **Save** interface.

Step 5 Click **OK**.

The system starts to export files. The file downloading interface is displayed. See Figure 7-41.

Figure 7-41 Download



- Click **Pause all** to pause all download tasks. Click **Start all** to resume download tasks.
- Click **Clear completed columns** to delete all downloaded tasks.
- Click  of the corresponding task to pause download task. Click  to resume download.
- Click  of the corresponding task to delete download task.

7.2.5 Video Tag

Tag specific video segments or pictures for the ease of search. For details about viewing tagged files, see "9.1.1 Video Tag Management."

Step 1 On the **LIVE** interface, click , and then select **SEARCH**.

The **SEARCH** interface is displayed. See Figure 7-38.

Step 2 Search for pictures or videos.

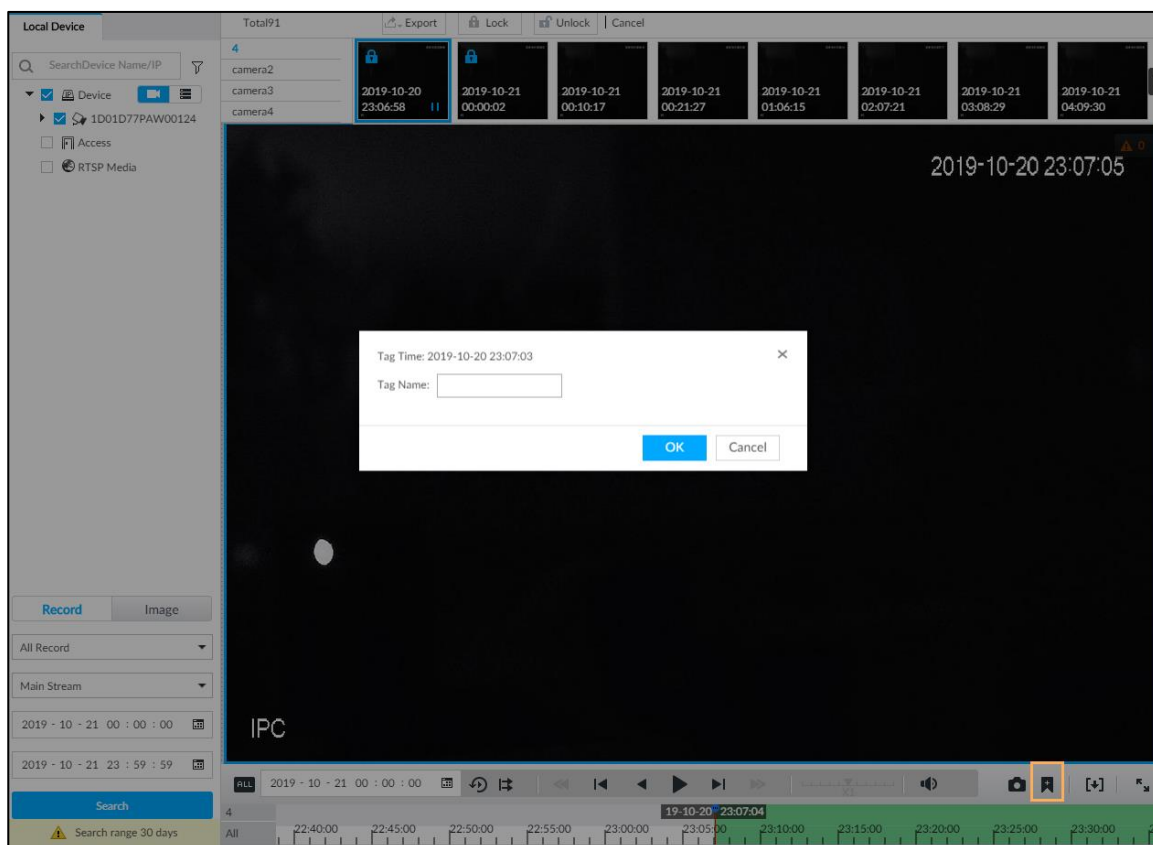
- 1) Click the **Record** or **Image** tab.
- 2) Select a camera, and then set search conditions.
- 3) Click **Search**.

The search results are displayed. See Figure 7-39.

Step 3 Click  at the lower-right corner of the playback window.

The following dialogue box is displayed. See Figure 7-42.

Figure 7-42 Tag



Step 4 Enter tag name, and then click **OK**.

7.2.6 Locking Files

Lock specific videos or pictures so they cannot be viewed. An locked file can only be viewed after being unlocked.

Step 1 On the **LIVE** interface, click , and then select **SEARCH**.

The **SEARCH** interface is displayed. See Figure 7-38.

Step 2 Search for pictures or videos.

- 1) Click the **Record** or **Image** tab.
- 2) Select a camera, and then set search conditions.
- 3) Click **Search**.

The search results are displayed. See Figure 7-39.

Step 3 Select the video files to be locked.

- Point to the thumbnail, and then click to select the video.
- You can click **Cancel** to cancel the selected videos.

Step 4 Click **Lock**.

Step 5 (Optional) Click **Unlock** to unlock the locked videos.

You can also unlock videos in **FILE > FILE LOCKED**. See "9.1.2 FILE LOCKED."

7.3 Alarm List


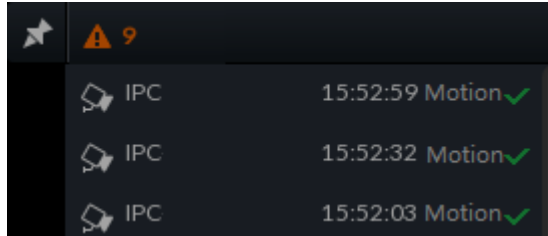
Click  to display alarm list. See Figure 7-43. It is to view alarm device name, alarm time and alarm type.

Figure 7-43 Alarm list








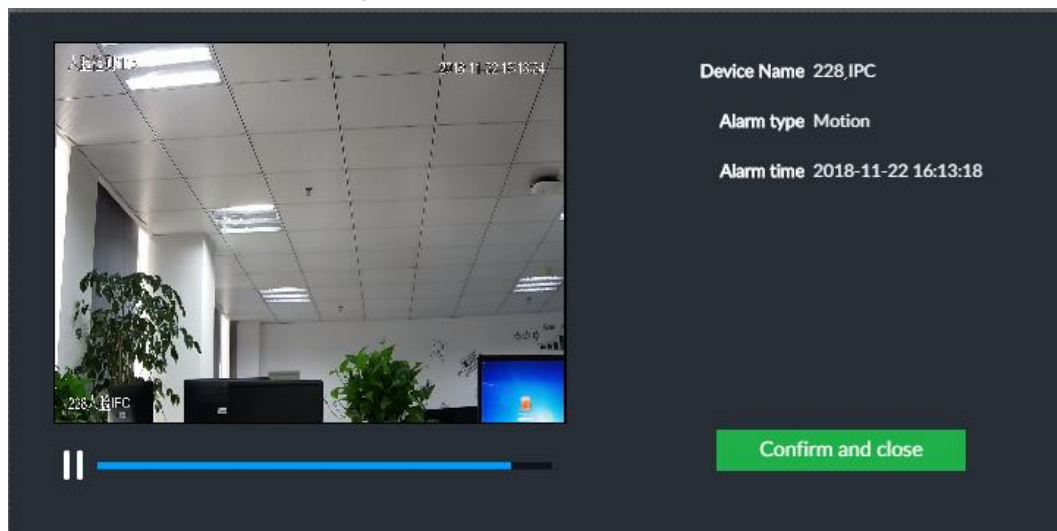
- Number 9 is the number of alarm event to be processed. The value changes according to alarm amount. It displays maximum 200 unprocessed alarm events.
- Click  to lock alarm list. The alarm list is open and cannot hide. Click the icon again to cancel lock function. Move the mouse pointer to other position, and the alarm list displays for a period of time and then automatically hides.
- Click  to confirm alarm event. The confirmed event will be removed from the alarm list.
- Click the alarm event on the alarm list. The device displays the 20 seconds video before and after the alarm event occurred. See Figure 7-44.
 - ◇ Click  to pause play. Now the icon becomes . Click  again to continue to play.
 - ◇ Click **OK and close**, confirm the alarm event and then exit the interface.

Figure 7-44 Alarm video



7.4 Display Management


Enable connected display or lock the screen.

7.4.1 Multiple-screen Control

Device can connect to multiple displays at the same time. You can select a display you want to use.





- The multiple-screen control function is for local menu only.
- Enter **Display Output** interface, you can enable a display or set its resolution. See "8.8.3 Display" for detailed information.
- The interface might vary since the connected display amount is not the same.

Click . The **Display** interface is displayed. See Figure 7-45.

- SN 1–3 represent displays connected to HDMI 1–HDMI 3. The main screen refers to the device connected to VGA and HDMI 1 port (The HDMI/VGA port on Figure 7-45.). The displays connected to the HDMI 2 and HDMI 3 are the sub screens. The output interfaces of main screen and the sub screen are not the same and the supported functions are different. See Table 7-14 for detailed information.
- VGA and HDMI 1 are outputting the same video source. Three HDMI ports can output different video sources.



-  means connected and enabled display.  means connected but not enabled display.



- Click  or  to disable or enable display. Device adopts main screen by default and the main screen cannot be disabled.

Figure 7-45 Display

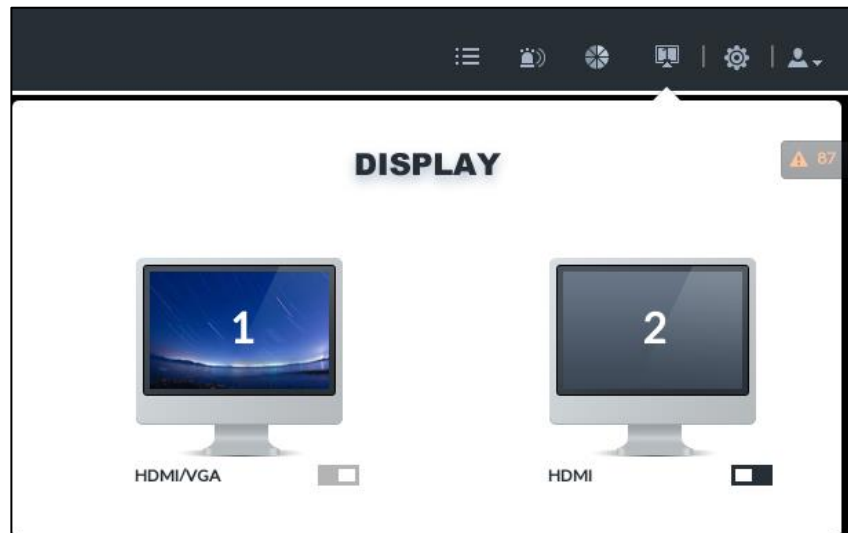



Table 7-14 Difference between main screen and sub screen

Name		Main screen	Sub screen
Function Operations	User operation (Login, log out, modify password, lock)	Supported	Supported
	Preview and Monitor	Supported	Supported
	Search	Supported	Supported
	Confirm alarm	Supported	N/A

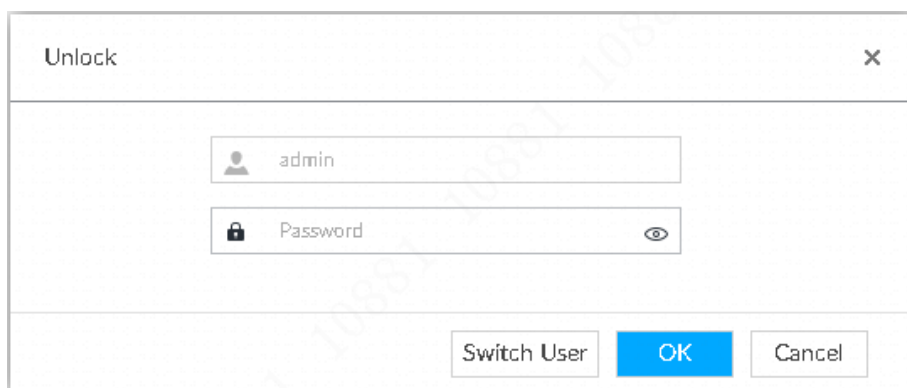
Name		Main screen	Sub screen
	File Management	Supported	Supported
	Intelligent Analytics	Supported	Supported
	Multiple-screen control	Supported	N/A
	System Info	Supported	Supported
	Background Task	Supported	Supported
	Operation and Maintenance Management	Supported	Supported
	Device Operation (Reboot, shut down)	Supported	N/A
System Configuration	Device, network, event, storage, Account, security strategy, and system management.	Supported	N/A

7.4.2 Locking Screen

Click  and then select Lock to lock the screen. The screen stops at current interface and cannot operate other functions.

If you want to unlock the screen, click any position on the screen, enter password or user other account to login. See Figure 7-46.

Figure 7-46 Unlock screen

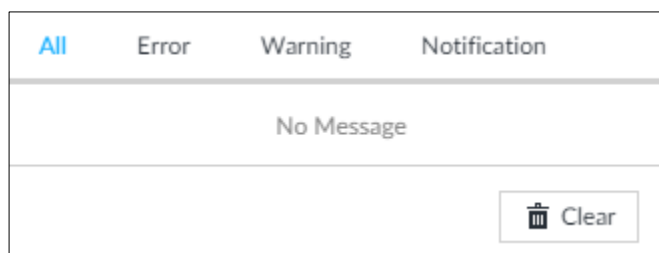


7.5 System Info


View system information including system error, system alarm and system notification.

Click  to display background task list. See Figure 7-47.

Figure 7-47 System info



- Click **All**, **Error**, **Warning**, or **Notification** tab to view the corresponding system information list.

- Click  to clear the corresponding system information.
- Click **Clear** to clear system information under current tab.
For example, click **All** tab and then click **Clear** button to clear all system information.
Click **Error** tab and then click **Clear** button to clear all system error information.

7.6 Background Task

View background task running status.


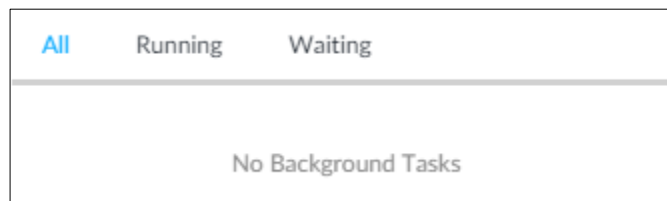
Click , device displays background task list. See Figure 7-48. Click **All**, **Running**, or **Waiting** to view the corresponding background task list.

Figure 7-48 Background task



7.7 Buzzer

View buzzer alarm messages.


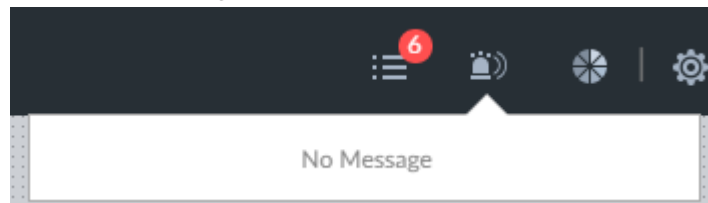
Click . The alarm messages are displayed. See Figure 7-49.

Figure 7-49 Buzzer



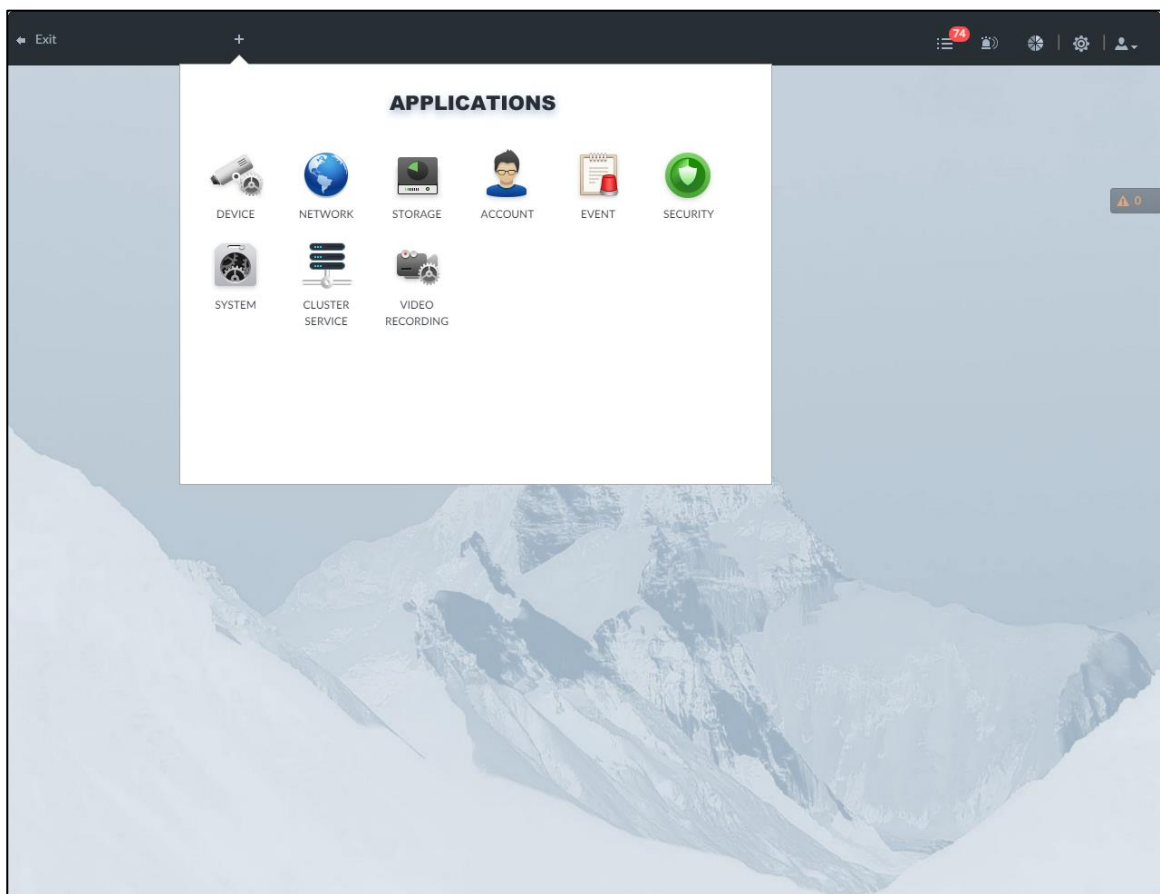
8 System Configuration

This chapter introduces system configuration functions such as managing remote device, setting network, setting alarm event, setting HDD storage, managing user information, setting device security strategy, and setting system parameters.


8.1 Configuration Interface

Click . The following interface is displayed. See Figure 8-1.



Figure 8-1 Configuration interface




On this interface, you can:

- Click the corresponding app icon to go to the corresponding interface. The task column displays current running app name. Move the mouse pointer to the app name and then click  to close the app.
- Click **Exit** to exit the interface.

8.2 Device Management

Click  or click  on the configuration interface, and then select **DEVICE**. The **DEVICE** interface is displayed. See Figure 8-2. You can set IVSS or remote devices.

- Select the root node  in the resource tree to set IVSS name and storage plan.
- Select a remote device in the device list. Set its property, connection, video, OSD, and storage plan.




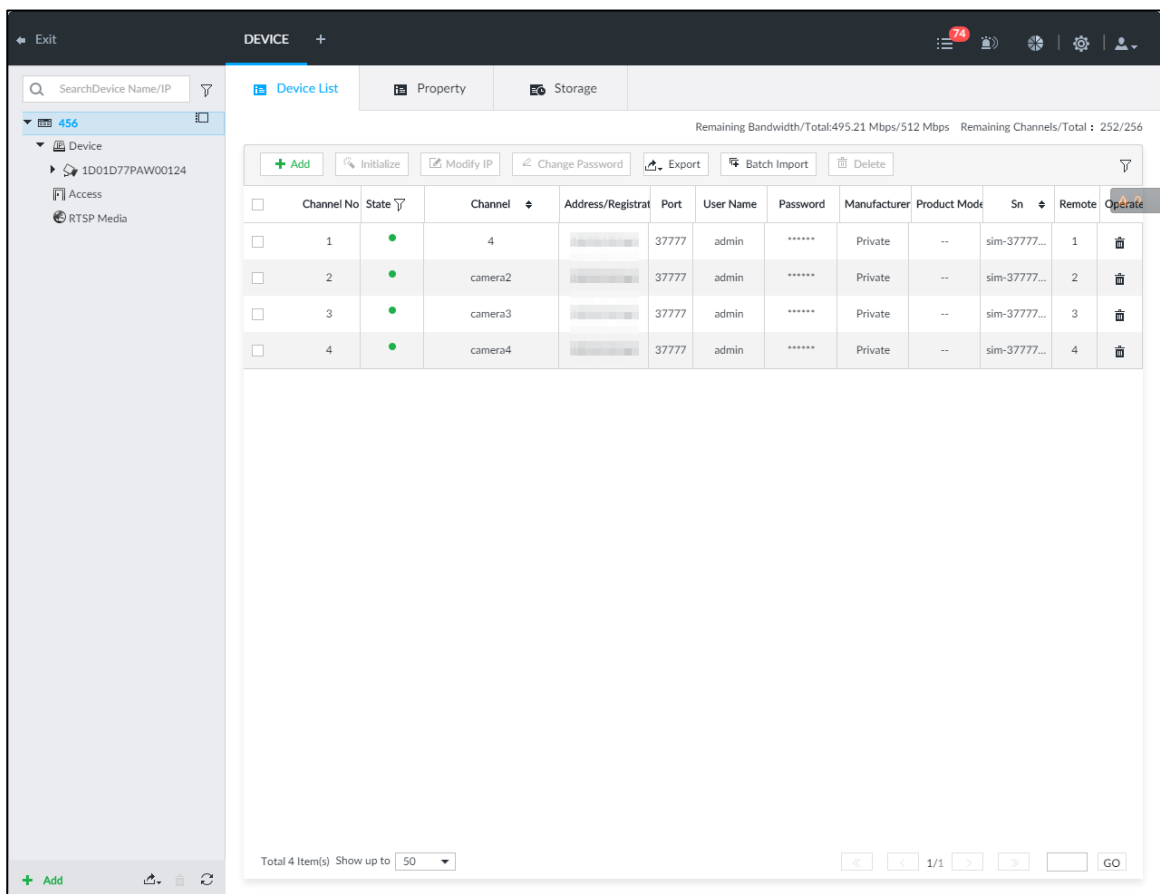
Click  or click **Add** to add remote device to the system. See "5.4.2 Adding Remote Device" for detailed information.

Figure 8-2 Device management




8.2.1 Local Device

Set device property and record storage plan.

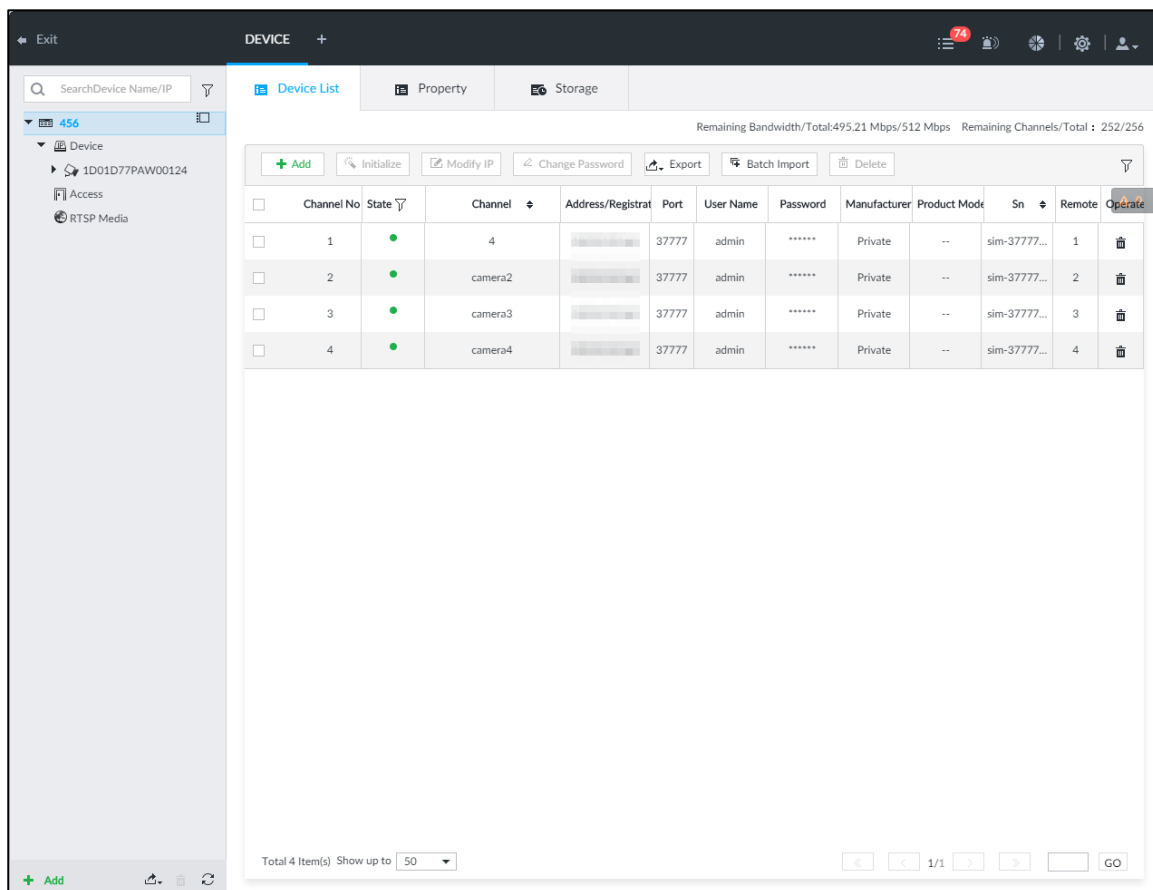
8.2.1.1 Configuring Property Parameters


Set device name, view device information.

Step 1 Click , and then select **DEVICE**.

The **DEVICE** interface is displayed. See Figure 8-3.

Figure 8-3 Device



Step 2 Select the root node  in the resource tree, and then click the **Property** tab.

The **Property** interface is displayed.

Step 3 Set parameters. For details, see Table 8-1.

Table 8-1 Property parameters description

Parameters	Description
Name	Set device name.
Description	Enter device description.
Device info	Displays device info, including type, SN, MAC, video in/out, audio in/out, Alarm in/out and system version.

Step 4 Click **Save**.

8.2.1.2 Configuring Storage Plans


Set device global record and image storage plan according to the actual situation.



In this interface, the record and image storage plan is for all registered remote device. You can select one remote device to set specified storage plan. See "8.2.2.3.5 Storage" for detailed information.

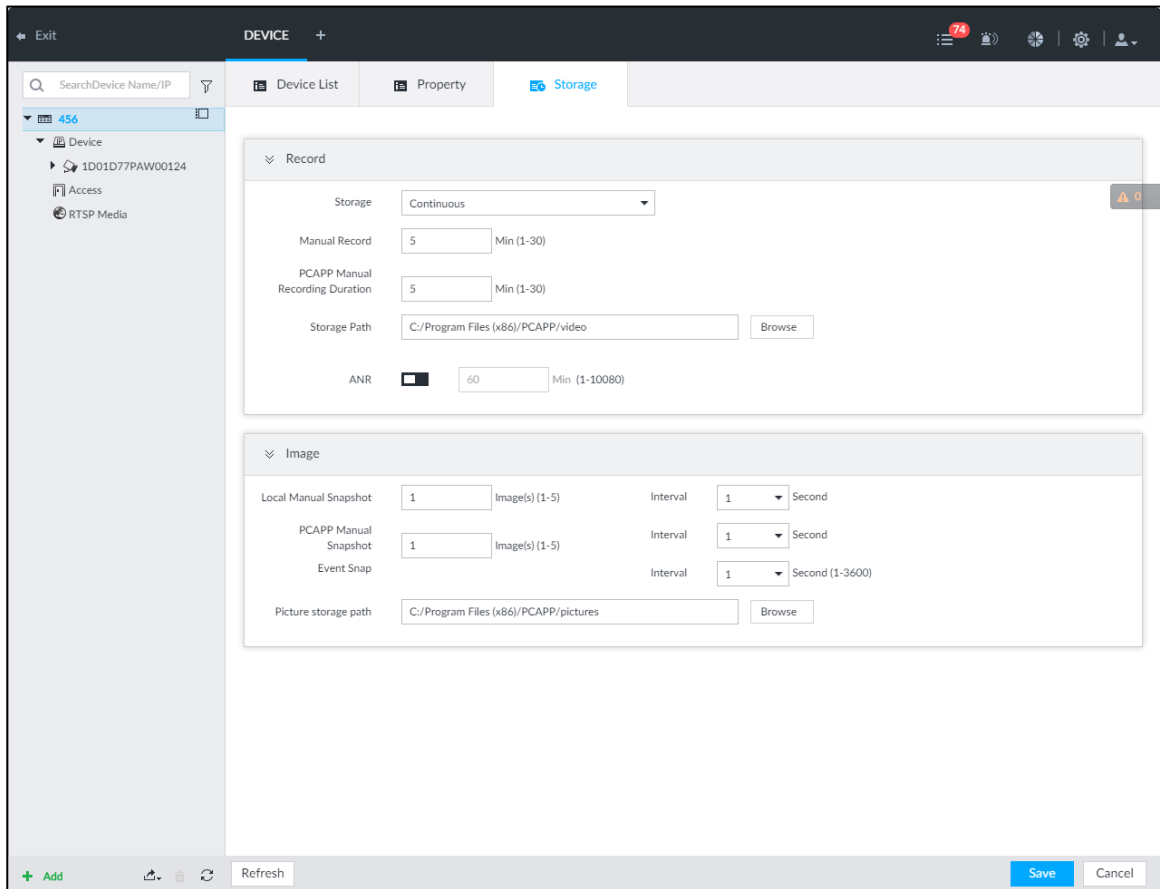
Step 1 Click , or click  on the configuration interface, and then select **DEVICE**.

The **DEVICE** interface is displayed.

Step 2 Select the root node  in the resource tree, and then click **Storage** tab.


The storage interface is displayed. See Figure 8-4.





Figure 8-4 Storage



Step 3 Set parameters. See Table 8-2.

Table 8-2 Storage parameters description

Parameters		Description
Record	Storage	<p>Set record strategy.</p> <ul style="list-style-type: none"> Continuous Recording: 24-hour continuous recording. Not Recording: Device is not recording. Event Recording: Device only records when there is corresponding alarm event. Scheduled: Record in the scheduled time. Scheduled & Event: Record in the scheduled time and also on the basis of event-triggering.
	ANR	<ul style="list-style-type: none"> When a camera gets disconnected with IVSS, it stores the recorded videos in its local SD card. When the camera is connected again, it will upload the video during the disconnection to IVSS. Set the maximum length of the to-be-uploaded video so that after getting reconnected, the camera will only upload video of the pre-defined length to IVSS. <p> Make sure that the camera has an SD card.</p>

Parameters		Description
	Manual Record (duration)	Set manual record file length. On the LIVE interface, click  to start record. If you do not click the icon to stop record, system stops recording automatically according to the record length here.
	PCAPP Manual Recording Duration	Set the time length of manual recording performed on the PCAPP client. Click  to start manual recording on the PCAPP client. The manual recording automatically finishes at the end of the pre-defined time period.
	Storage Path	Click Browser to set manual record storage path.  Only PCAPP supports this function.
Image	Local Manual Snapshot	Set manual snapshot amount and snapshot speed.
	PCAPP Manual Snapshot	Set the number and speed of manual snapshot on the PCAPP.
	Event Snap	Set event snapshot interval. Select Customize to set customized interval. The maximum internal is 3600 seconds.
	Picture storage path	Click Browser to set snapshot image storage path.  Only PCAPP supports this function.

Step 4 Click **Save**.

8.2.2 Remote Device

The Device supports to add remote device, modify its IP address and configurations, and export its information.



See "5.4.2 Adding Remote Device" for detailed information.

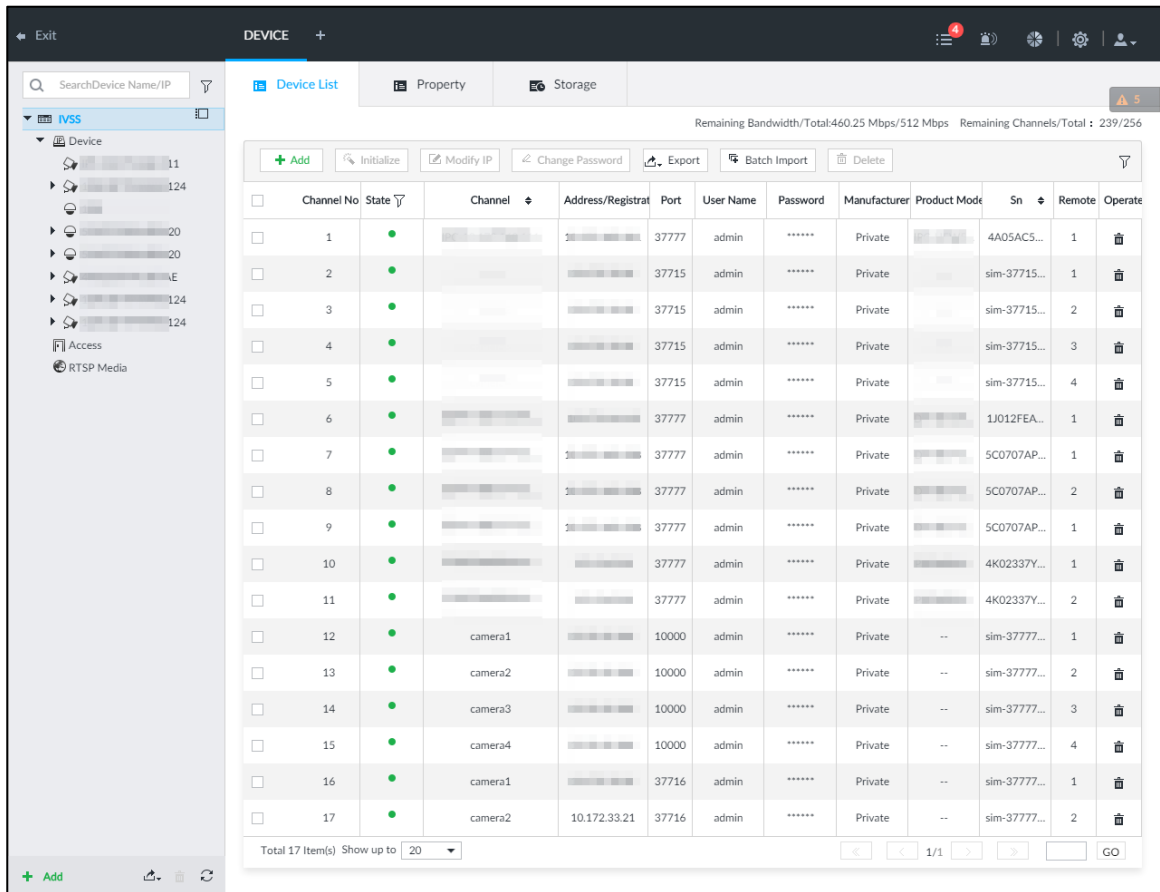
8.2.2.1 Viewing Remote Devices

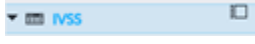
View connected remote devices. For details about adding devices, see "5.4 Configuring Remote Device."

Step 1 Click , or click  on the configuration interface, and then select **DEVICE**.

The **DEVICE** interface is displayed. See Figure 8-5.

Figure 8-5 Device management

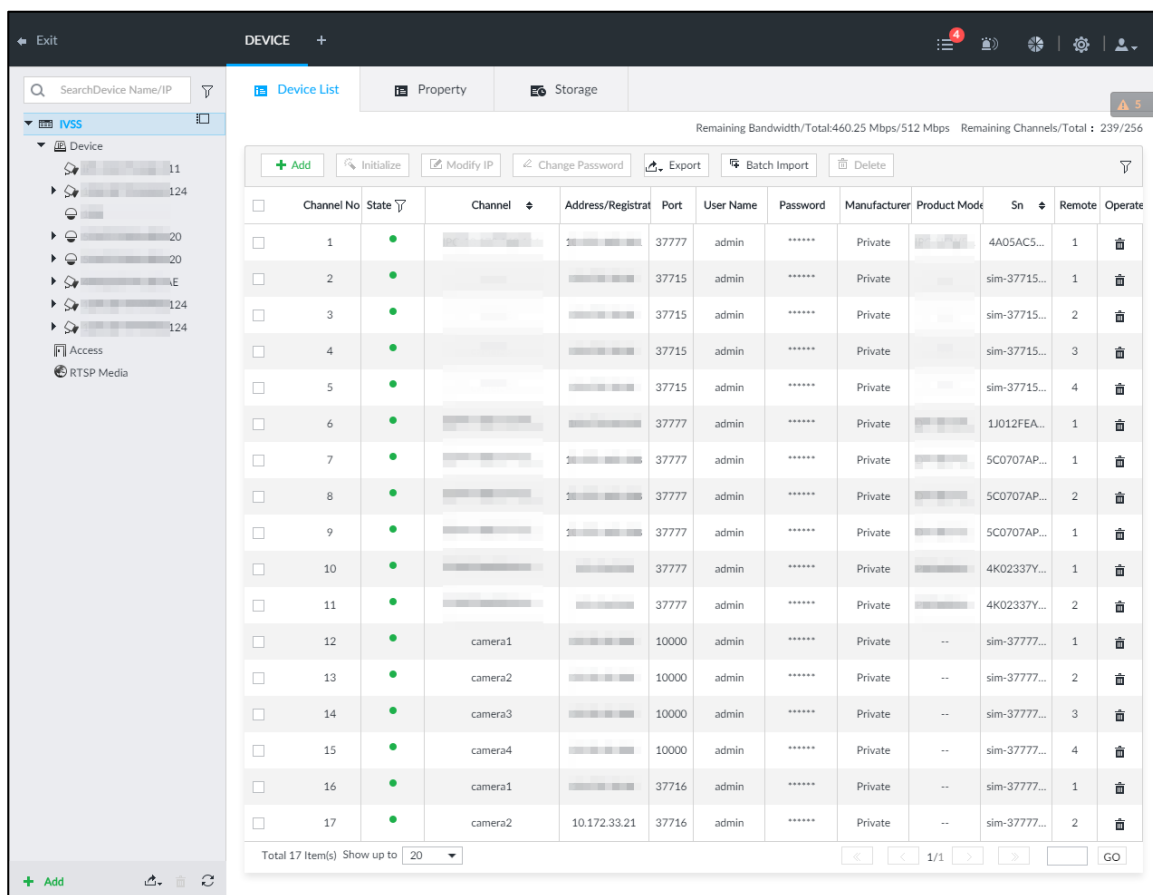


Step 2 Select the root node  in the resource tree, and then click the





Device List tab.


The **Device List** interface is displayed. See Figure 8-6.

Figure 8-6 Device list



Step 3 View details of connected devices, including IP address and serial number.

- In the **Status** column,  indicates that the device is offline.
- In the **Status** column,  indicates that the device is online.
- In the **Status** column,  indicates that the device is exception. Point to , and then you are prompted about the details of the exception, such as being uninitialized, device mismatch, and wrong password.

Step 4 (Optional) Click  to set filtering conditions for search.

Step 5 (Optional) You can select the uninitialized devices to initialize them. For details, see "5.4.1 Initializing Remote Device."

8.2.2.2 Changing IP Address

Modify IP address of the remote device connected or not connected to the Device.

8.2.2.2.1 Modifying IP of Unconnected Devices

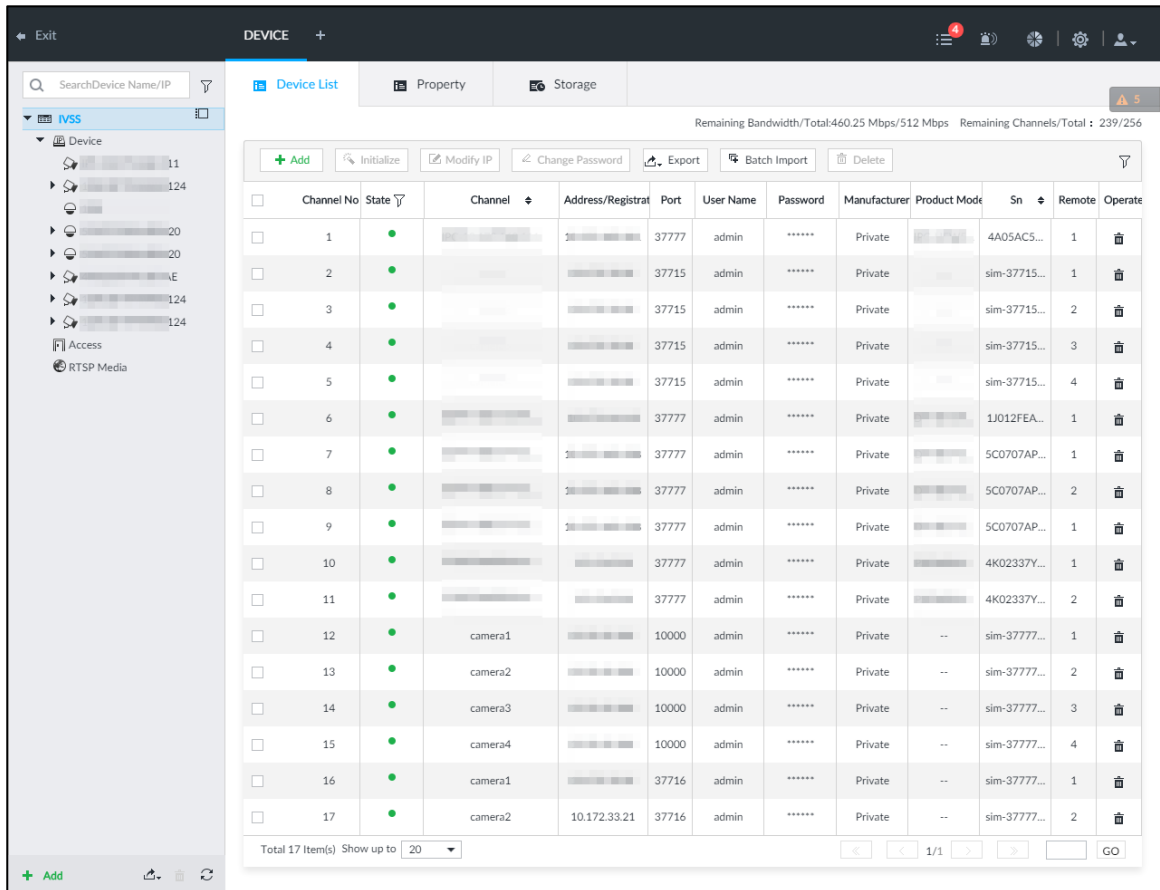


- You can only modify the IP address of initialized devices. For remote device initialization, see "5.4.1 Initializing Remote Device."
- You can only modify the IP address of remote devices connected with private protocol.

Step 1 Click , or click  on the configuration interface, and then select **DEVICE**.

The **DEVICE** interface is displayed. See Figure 8-7.

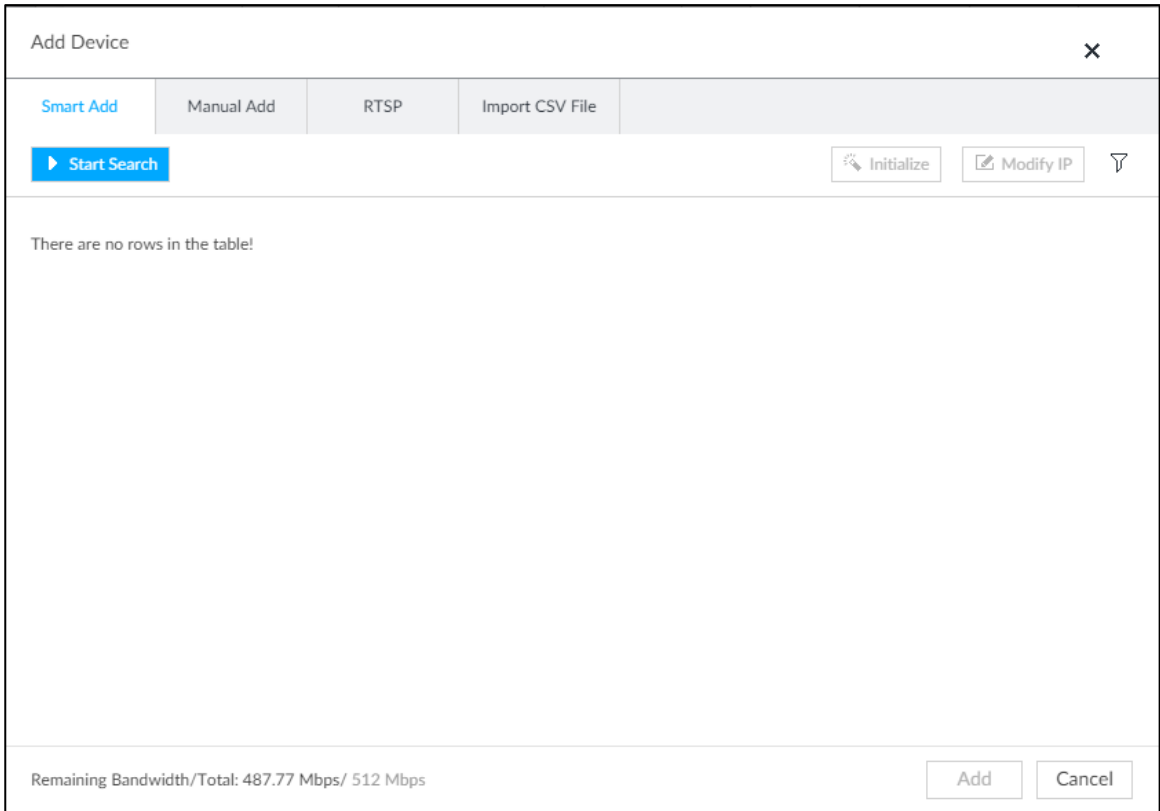
Figure 8-7 Device management



Step 2 Click  or click **Add**, and then select **Smart Add**.

The **Smart Add** interface is displayed.

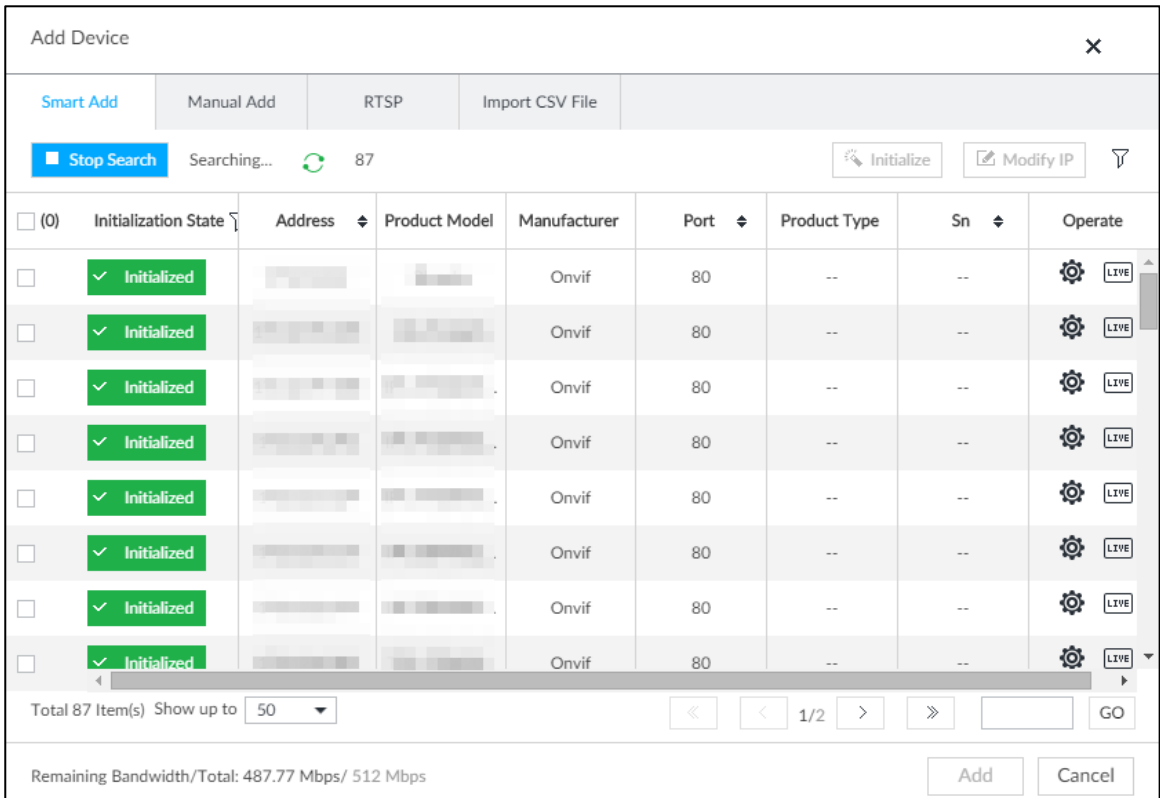
Figure 8-8 Smart add



Step 3 Click **Start Search**.

System starts to search and displays result. See Figure 8-9.

Figure 8-9 Remote device



Step 4 Select a remote device and then click **Modify IP**.

The **Modify IP** interface is displayed. See Figure 8-10.

Figure 8-10 Modify IP (1)

Step 5 Enter the static IP address, subnet mask, gateway, and incremental value.



- Enter incremental value only when multiple remote devices are modified. If you want to change IP addresses of several devices at the same time, system allocates IP address one by one according to your setting at the fourth bit of the IP address.
- If there is IP conflict when changing static IP address, device pops up IP conflict dialogue box. To change IP addresses in batches, system automatically skips the conflicted IP and begins the allocation according to the incremental value.

Step 6 Enter the user name and password of remote device.



When you are changing several device IP addresses, make sure that the user name and password of these remote devices are the same.

Step 7 Click **Next**.

The modification result is displayed.

Step 8 Click **OK** to complete the modification.

8.2.2.2.2 Modifying IP of Connected Devices

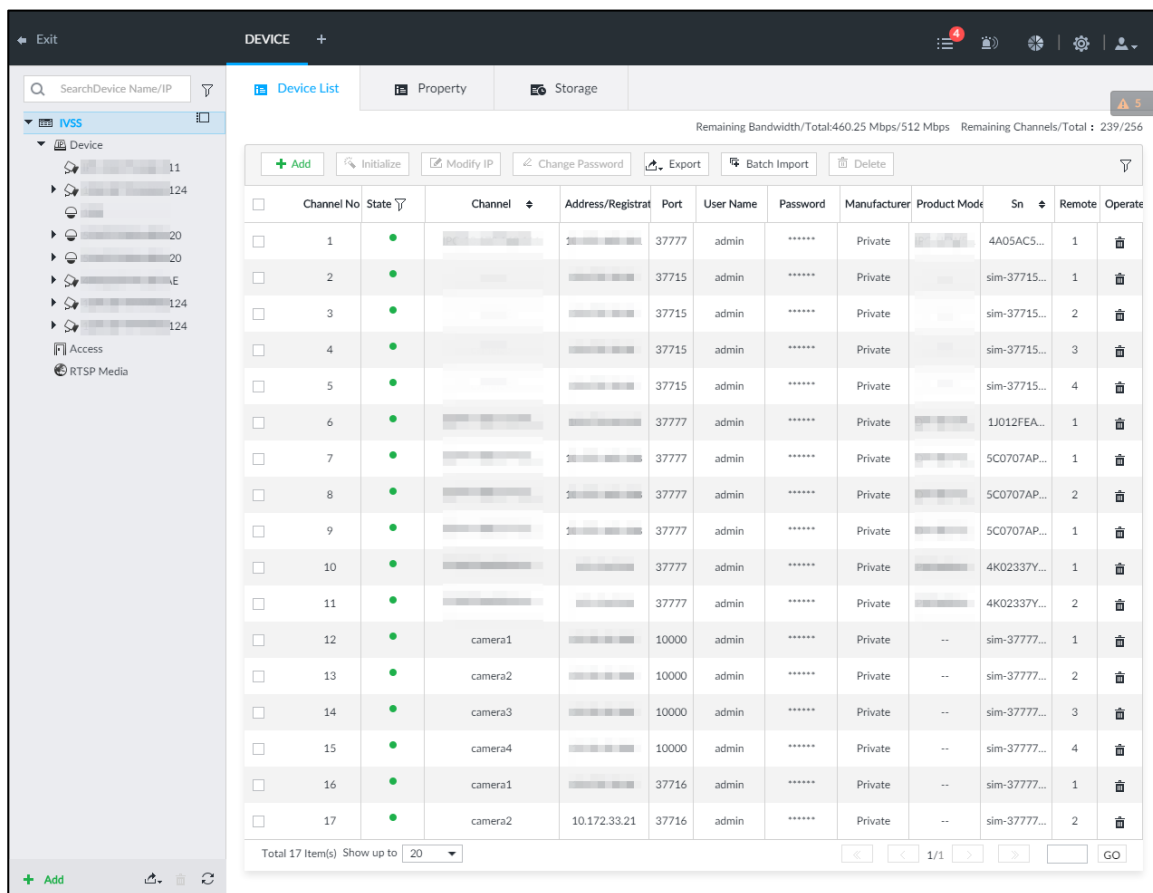


- You can only modify the IP address of initialized devices. For remote device initialization, see "5.4.1 Initializing Remote Device" for detailed information.
- You can only modify the IP address of remote devices connected through private protocol.
- To modify the IP address of connected devices one by one, see "8.2.2.3.2 Configuring Connection Information."


















Step 1 Click , or click  on the configuration interface, and then select **DEVICE**.

The **DEVICE** interface is displayed. See Figure 8-11.

Figure 8-11 Device management



The screenshot shows the 'DEVICE' management interface. On the left is a sidebar with a search bar and a tree view containing 'IVSS' and 'Device' (with sub-items 11, 124, 20, 20, 124, 124, Access, RTSP Media). The main area has tabs for 'Device List', 'Property', and 'Storage'. Below the tabs are buttons for '+ Add', 'Initialize', 'Modify IP', 'Change Password', 'Export', 'Batch Import', and 'Delete'. A table displays 17 devices with the following columns: Channel No, State, Channel, Address/Registrar, Port, User Name, Password, Manufacturer, Product Model, Sn, Remote, and Operate. The table data is as follows:

Channel No	State	Channel	Address/Registrar	Port	User Name	Password	Manufacturer	Product Model	Sn	Remote	Operate
1	●			3777	admin	*****	Private		4A05AC5...	1	
2	●			37715	admin	*****	Private		sim-37715...	1	
3	●			37715	admin	*****	Private		sim-37715...	2	
4	●			37715	admin	*****	Private		sim-37715...	3	
5	●			37715	admin	*****	Private		sim-37715...	4	
6	●			3777	admin	*****	Private		1J012FEA...	1	
7	●			3777	admin	*****	Private		5C0707AP...	1	
8	●			3777	admin	*****	Private		5C0707AP...	2	
9	●			3777	admin	*****	Private		5C0707AP...	1	
10	●			3777	admin	*****	Private		4K02337Y...	1	
11	●			3777	admin	*****	Private		4K02337Y...	2	
12	●	camera1		10000	admin	*****	Private	--	sim-3777...	1	
13	●	camera2		10000	admin	*****	Private	--	sim-3777...	2	
14	●	camera3		10000	admin	*****	Private	--	sim-3777...	3	
15	●	camera4		10000	admin	*****	Private	--	sim-3777...	4	
16	●	camera1		37716	admin	*****	Private	--	sim-3777...	1	
17	●	camera2	10.172.33.21	37716	admin	*****	Private	--	sim-3777...	2	

At the bottom of the table, it says 'Total 17 Item(s) Show up to 20'. There are also navigation buttons for '<', '>', '1/1', and 'GO'.

Step 2 Select a remote device and then click **Modify IP**.

The **Modify IP** interface is displayed. See Figure 8-10.

Figure 8-12 Modify IP (1)

(1) Sn	IP Address
1	192.168.1.1

DHCP Static

Static IP Address: . . . Incremental Value: 1

Subnet Mask: . . .

Gateway: . . .

User Name: _____

Password: _____

support Private only

Next Cancel

Step 3 Enter the IP address, subnet mask, gateway, and incremental value.



- Enter incremental value only when multiple remote devices are modified. If you want to change IP addresses of several devices at the same time, system allocates IP address one by one according to your setting at the fourth bit of the IP address.
- If there is IP conflict when changing static IP address, device pops up IP conflict dialogue box. To change IP addresses in batches, system automatically skips the conflicted IP and begins the allocation according to the incremental value.

Step 4 Enter the user name and password of remote device.



When you are changing several device IP addresses, make sure that the user name and password of these remote devices are the same.

Step 5 Click **Next**.

The result of IP modification is displayed.

Step 6 Click **OK**.

8.2.2.3 Configuring Remote Devices


Set remote device property, connection information, and video parameters.



Different remote devices have different interfaces. See the actual interface for detailed information.

8.2.2.3.1 Configuring Device Property

Set remote device name, and view device information.

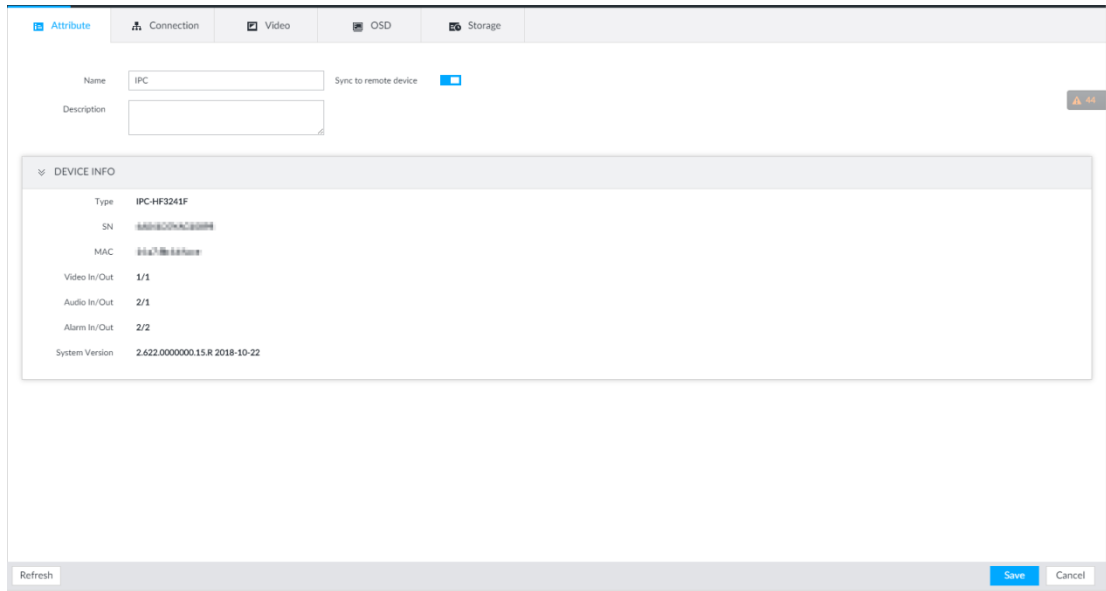
Step 1 Click , or click  on the configuration interface, and then select **DEVICE**.

The **DEVICE** interface is displayed.

Step 2 Select a remote device on the left panel and then click **Property** tab.

The **Property** interface is displayed. See Figure 8-13.

Figure 8-13 Property



Step 3 Set parameters. For details, see Table 8-3.

Table 8-3 Property parameters description

Parameters	Description
Name	Set remote device name. Enable Sync to remote device and save the settings to synchronize new name to the remote device.
Description	Input remote device description.
Device info	Displays remote device information. It includes remote device type, SN, MAC address, video in/out, audio in/out, alarm in/out, and system version.

Step 4 Click **Save**.

8.2.2.3.2 Configuring Connection Information

Set connection information of remote device, such as IP address and port number.

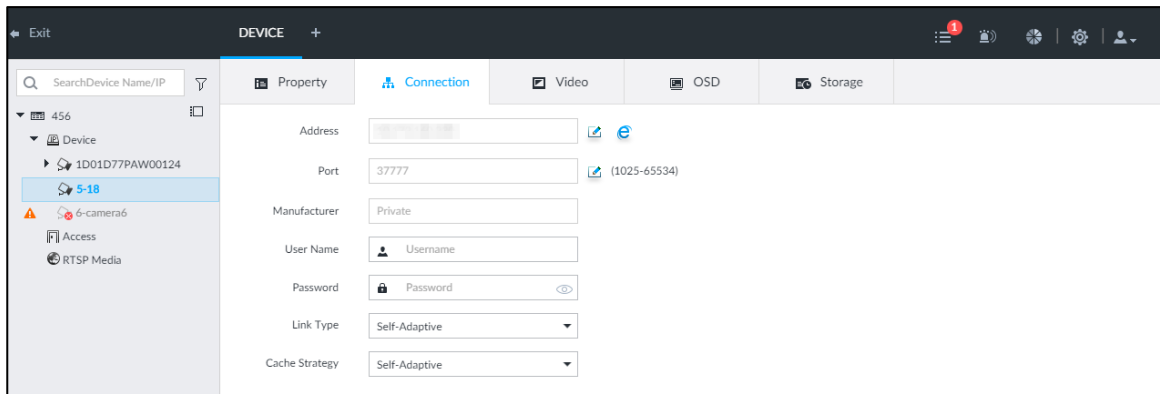
Step 1 Click , or click  on the configuration interface, and then select **DEVICE**.

The **DEVICE** interface is displayed.


Step 2 Select a remote device on the left panel and then click the **Connection** tab.

The **Connection** interface is displayed. See Figure 8-14.

Figure 8-14 Connection information

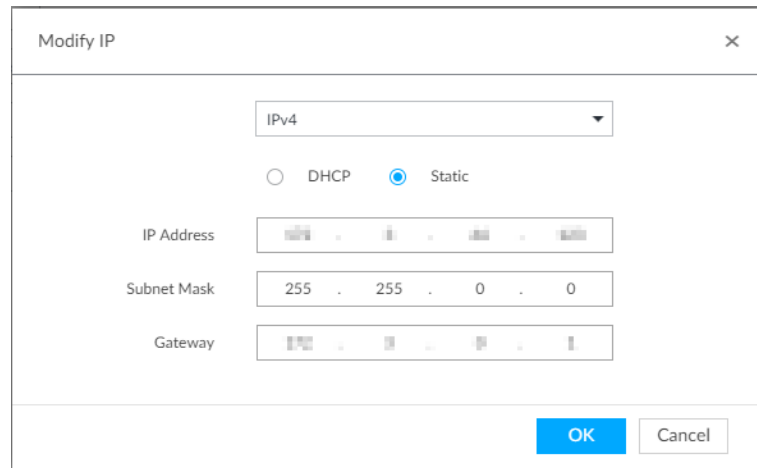


Step 3 Change IP address.

- 1) Click  of the corresponding address.

The **Modify IP** interface is displayed. See Figure 8-15.

Figure 8-15 Modify IP




- 2) Select IP mode.
 - Check **DHCP**, there is no need to enter IP address, subnet mask, and default gateway. Device automatically allocates dynamic IP address to the remote device.
 - Check **Static**, and then enter IP address, subnet mask, default gateway and incremental value.



- Enter incremental value only when multiple remote devices are modified. If you want to change IP addresses of several devices at the same time, system allocates IP address one by one according to your configuration at the fourth bit of the IP address.
- If there is IP conflict when changing static IP address, device pops up IP conflict dialogue box. To change IP addresses in batches, device automatically skips the conflicted IP and begins the allocation according to the incremental value.

- 3) Click **OK** to save setting.

Step 4 Change port number.

- 1) Click  of the corresponding port.

The **Modify Port** interface is displayed. See Figure 8-16.

Figure 8-16 Port


- 2) Change port number.
- 3) Click **OK** to save setting.

Step 5 Set other parameters. See Table 8-4 for detailed information.


Table 8-4 Connection parameters description

Parameters	Description
Manufacturer	Displays the connection protocol of the remote device.
Username	Enter username and password of remote device. The new password can be set from 8 characters through 32 characters and contains at least two types from number, letter and special characters (excluding ' " ; : & and space). Enter a strong password according to the password strength indication.
Password	
Link type	Displays link type of the system and remote device. It is self-adaptive.
Cache strategy	Set cache strategy of remote device video stream. <ul style="list-style-type: none"> • Self-adaptive: System automatically adjusts video stream cache status according to the network bandwidth. • Real-time: Guarantee video real-timeness. When the network bandwidth is not sufficient, the video might not be fluent. • Fluency: Guarantee video fluency. When the network bandwidth is not sufficient, the video might not be clear.

Step 6 Click **Save**.

Step 7 (Optional) Click , and then you can go to the web interface of the remote device.



On the local interface of the Device, you cannot click  to go to the web interface of the remote device.

8.2.2.3.3 Configuring Video Parameters

Set different video parameters according to different bit stream types based on the bandwidth.

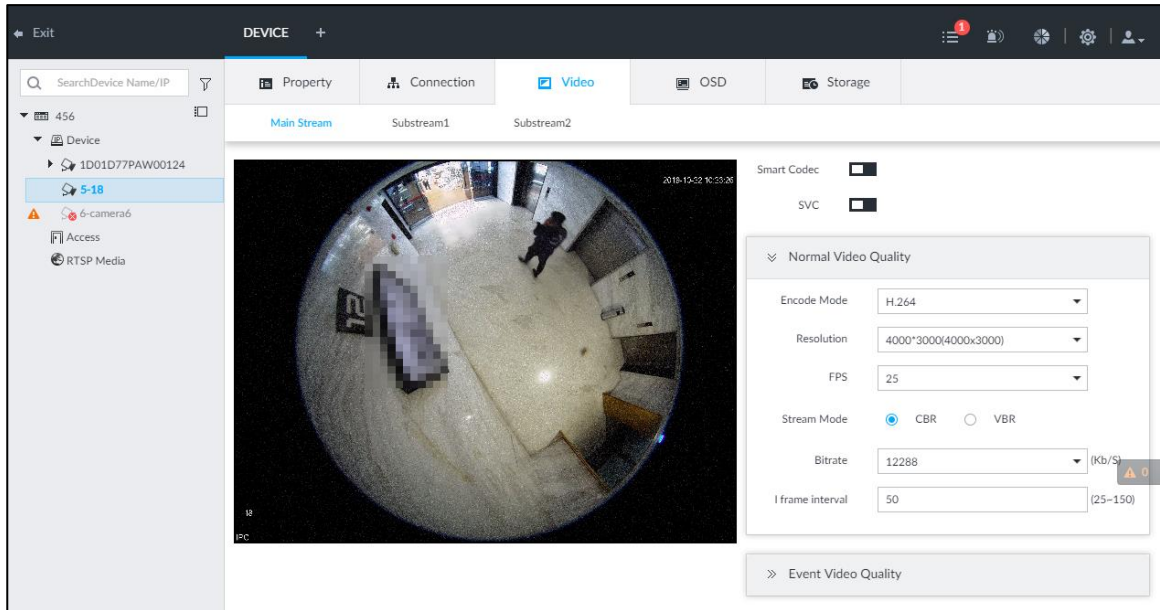
Step 1 Click , or click  on the configuration interface, and then select **DEVICE**.

The **DEVICE** interface is displayed.

Step 2 Select a remote device on the left panel and then click **Video** tab.

The **Video** interface is displayed. See Figure 8-17.




Figure 8-17 Video




Step 3 Set main stream, sub stream 1, or sub stream 2.

Step 4 Set general video quality parameters. See Table 8-5 for detailed information.

Table 8-5 Video parameters description

Parameters	Description
Smart Codec	<p>Enable this function to enhance performance of video compression and thus reduce storage space requirement.</p> <p> This function is only available for main stream.</p>
SVC	<p>Select the check box to enable SVC function. Select 1 or 2 from the drop-down list on the right. The default setup is 1, there is no scaled encoding.</p> <p> SVC refers to the scaled video coding. It can split the video stream to basic stream and enhanced scale.</p>
Encode mode	<p>Set video encode mode.</p> <ul style="list-style-type: none"> H.264: It is a highly compressed video encoding or encoding standard. At the same video quality, it has increased the compression rate by 2X compared with the MPEG-2. H.265: It is a new video encode standard coming after H.264. It has improved the complicated relationship among bit stream, encode quality, latch and algorithm on the previous standard. It can get the best encoding.
Resolution	<p>Set video resolution. The higher the resolution is, the better the video quality is.</p> <p> Different series products support different resolutions. See the actual interface for detailed information.</p>
FPS	<p>Set the frame amount displayed at each second. The higher the frame rate is, the more vivid and fluent the video is.</p>
Stream mode	<p>Set video bit stream control mode.</p> <ul style="list-style-type: none"> CBR: The bit stream changes slightly. The bit stream is near the value you set here. VBR: The bit stream might change according to the environment.

Parameters	Description
Quality	Set video quality. It includes low, middle, high.  It is null when the stream mode is CBR.
Bitrate	Set video bitrate. <ul style="list-style-type: none"> • Main stream: In the Bit Rate list, select a value or enter a customized value to change the image quality. The bigger the value is, the better the image will become. • Sub stream: In CBR mode, the bit stream changes around the value you set. In VBR mode, it changes according to the bit stream value, but its max value is near the specified value.
I frame interval	Set the P frame amount between two I frames. Usually we recommend it is the 2X of the frame rate.

Step 5 Enable **Event Video Quality** and set FPS and stream mode.



Event video quality is for main stream only.

Step 6 Click **Save**.

8.2.2.3.4 OSD

It is to overlay time information, and channel information on the video.

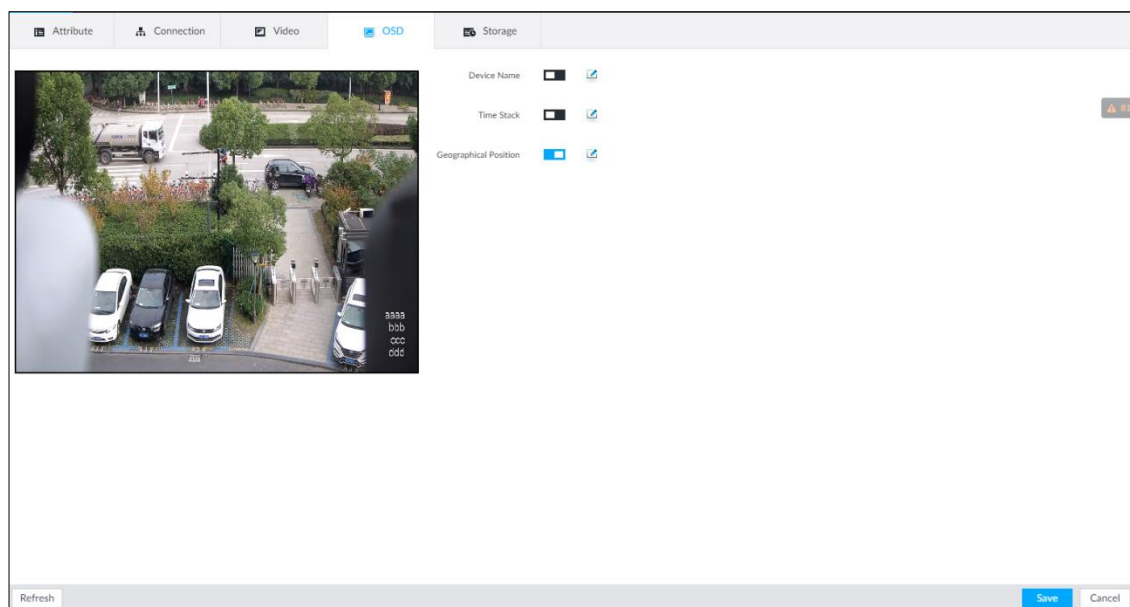
Step 1 Click  , or click  on the configuration interface, and then select **DEVICE**.

The **DEVICE** interface is displayed.


Step 2 Select a remote device on the left panel and then click **OSD** tab.

The **OSD** interface is displayed. See Figure 8-18.

Figure 8-18 OSD



Step 3 Enable OSD information according to actual requirements.

1) Click  to enable OSD function.

2) Click  .

The video displays the text boxes. See Figure 8-19, Figure 8-20 or Figure 8-21.

Figure 8-19 Device name

IP PTZ Camera

Figure 8-20 Time

2018-11-20 14:25:34

Figure 8-21 Geographical position



- 3) Set device name.









Skip this step if you do not want to use device name function.

- 4) Set geographical position information.



Skip this step if you do not want to use geographical position function.

Click  or  to create a text box. Enter the geographical position information.

- ◇ Click  to adjust font alignment mode.
- ◇ Click  or  again, add one text box at the top or the bottom of the text box.
- ◇ Click  to delete the text box.

- 5) Drag the text box to the proper position.

- 6) Click  to save.

Step 4 Click **Save**.

8.2.2.3.5 Storage

Set video file and image storage plan of remote device according to the actual situation.

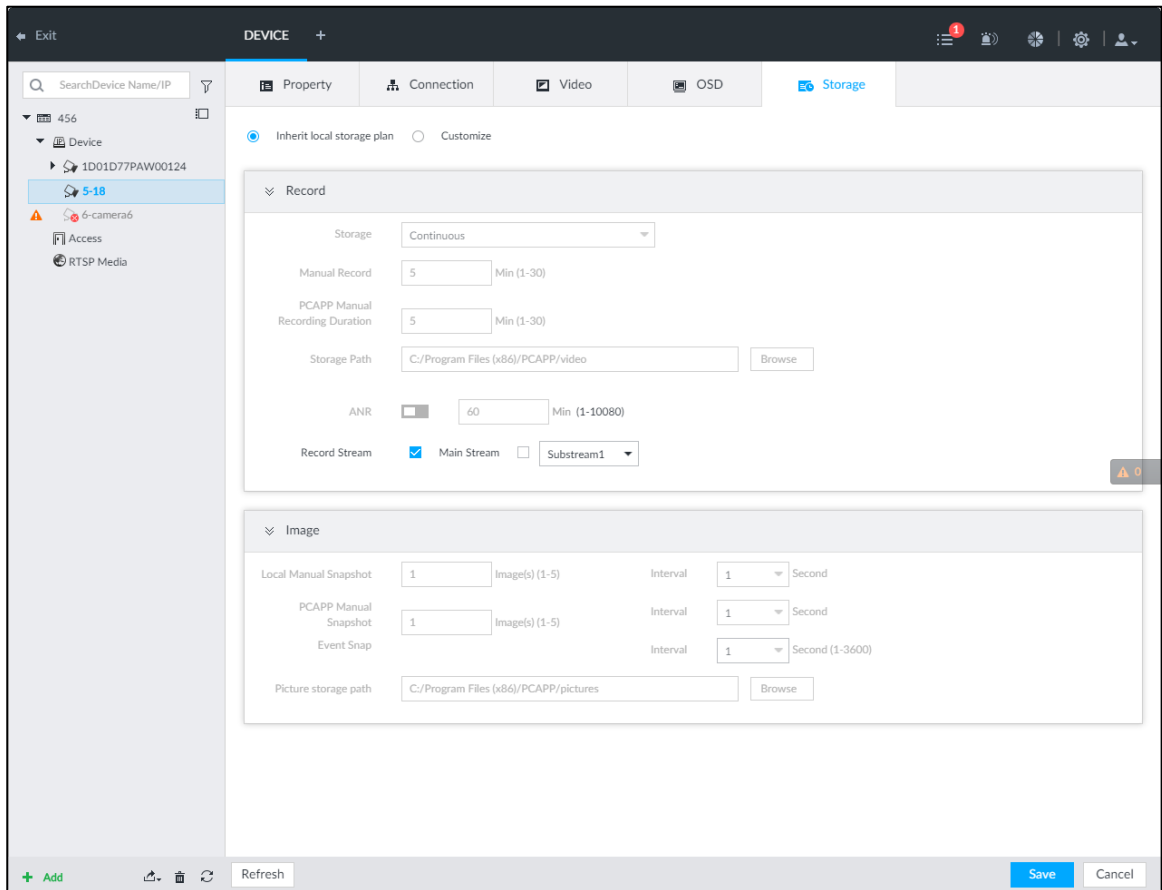
Step 1 Click , or click  on the configuration interface, and then select **DEVICE**.

The **DEVICE** interface is displayed.

Step 2 Select a remote device on the left panel and then click **Storage** tab.

The **Storage** interface is displayed. See Figure 8-22.

Figure 8-22 Storage



Step 3 Select Inherit local storage plan or Customize.

- **Inherit local storage plan:** The remote device adopts global storage plan of the Device. For details, see "8.2.1.2 Configuring Storage Plans."
- **Customize:** Set customized storage plan.






Step 4 Set parameters. For details, see Table 8-6.



Set record streams only if you select **Inherit local storage plan**.

Table 8-6 Storage parameters description

Parameters		Description
Record	Storage	<p>Set record strategy.</p> <ul style="list-style-type: none"> ● Continuous Recording: 24-hour continuous recording. ● Not Recording: Device is not recording. ● Event Recording: Device only records when there is corresponding alarm event. ● Scheduled: Record in the scheduled time. ● Scheduled & Event: Record in the scheduled time and also on the basis of event-triggering.

Parameters		Description
	ANR	<ul style="list-style-type: none"> When a camera gets disconnected with IVSS, it stores the recorded videos in its local SD card. When the camera is connected again, it will upload the video during the disconnection to IVSS. Set the maximum length of the to-be-uploaded video so that after getting reconnected, the camera will only upload video of the pre-defined length to IVSS.  <p>Make sure that the camera has an SD card.</p>
	Manual Record (length)	<p>Set manual record file length.</p> <p>On the LIVE interface, click  to start record. If you do not click the icon to stop record, system stops recording automatically according to the record length here.</p>
	PCAPP Manual Recording Duration	<p>Set the time length of manual recording performed on the PCAPP client.</p> <p>Click  to start manual recording on the PCAPP client. The manual recording automatically finishes at the end of the pre-defined time period.</p>
	Storage Path	<p>Click Browser to set manual record storage path.</p>  <p>Only PCAPP supports this function.</p>
Image	Local Manual Snapshot	Set manual snapshot amount and snapshot speed.
	Event Snap	<p>Set event snapshot interval.</p> <p>Select Customize to set customized interval. The maximum interval is 3600 seconds.</p>
	Picture storage path	<p>Click Browser to set snapshot image storage path.</p>  <p>Only PCAPP supports this function.</p>

Step 5 Click **Save**.

8.2.2.4 Exporting Remote Devices in Batches


Export the added remote device. When the device restores factory default settings or information of remote device is lost, export information of remote device to recover quickly.



See "5.4.2 Adding Remote Device" for detailed information.

Step 1 Click , or click  on the configuration interface, and then select **DEVICE**.

The **DEVICE** interface is displayed.

Step 2 Click  at the lower-left corner.

The **Export** interface is displayed. See Figure 8-23.



Click **Download Template** to download template file of the remote device, and add remote device through the template.

Figure 8-23 Export

Export

Encryption Yes No

Download Template OK Cancel

Step 3 Select encryption or not.

- If you select **Yes**, the system exports encrypted .backup file.
- If you select **No**, the system exports .csv file, which can be opened with Excel. The exported .csv file contains IP address, port number, channel number, channel name, manufacturer and username (excluding password) of the remote device.




When unencrypted file is exported, keep the file properly to avoid data leakage.

Step 4 Click **OK**.

The following prompt interface is displayed.

Step 5 Click **Save**.

File path might be different depending on interface operations. See actual interfaces.

- On PCAPP, click , select **Downloads** to view file saving path. For details, see "11.3 Viewing Downloads."
- Select file saving path during local operation.



Connect USB device to the system if you are on the local menu to operate.

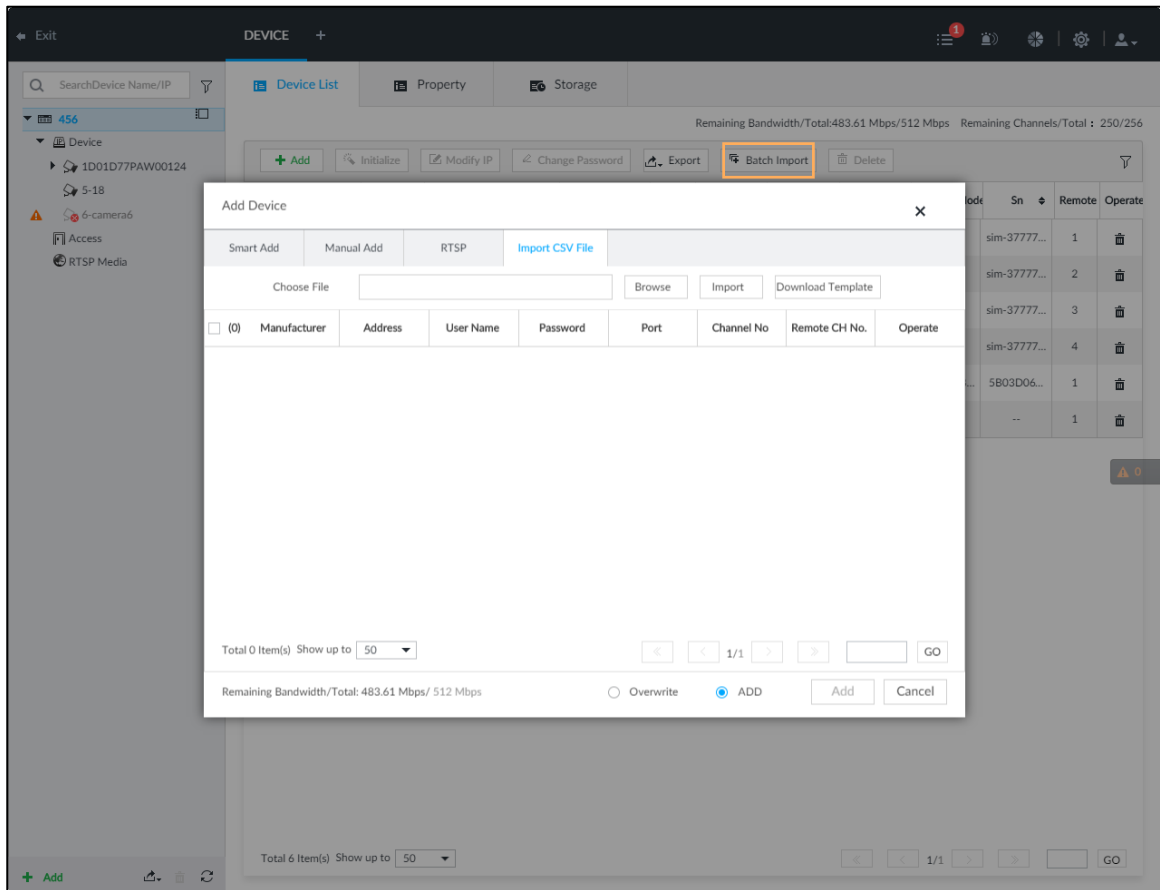
- During web operations, files are saved under default downloading path of the browser.

8.2.2.5 Importing Remote Devices in Batches

Import devices in batches by using the template.



On the **Device List** interface, click **Batch Import** to go to the **Add Device** interface. On the **Add Device** interface, click the **Import CSV File** tab. For further operation instruction about how to use the CSV file to import devices in batches, see "5.4.2.4 Batch Add."

Figure 8-24 Import in batches



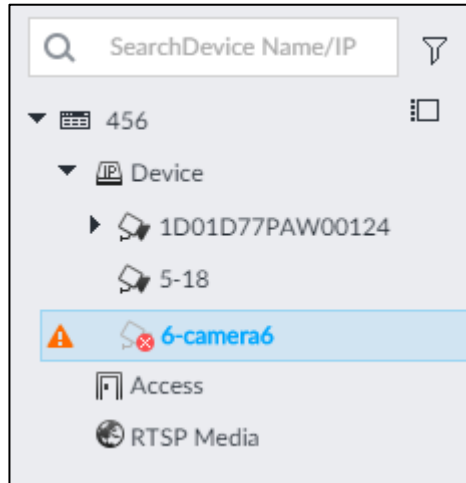
8.2.2.6 Connecting Remote Devices

On the **Device** interface, view connection status of remote device in the device list. See Figure 8-25.

When the remote device name and icon is black,  for example, it means the remote device is online. When they are gray,  for example, it means the remote device is offline.







- Right-click the offline device, and then select **Connect** to connect the device.
- Right-click the online device, and then select **Disconnect** to disconnect the device.
- Right-click the online device, and then select **Open WEB** to go to the web interface of the device.

Figure 8-25 Device list



8.2.2.7 Deleting Remote Devices

On the **Device** interface, delete the registered remote device.

- Delete one by one:
 - ◇ Select a remote device and then click  to delete.
 - ◇ On the **Device List** interface, right-click a remote device and then click **Delete**.
 - ◇ On the **Device List** interface, select a remote device, and then click .
 - ◇ On the **Device List** interface, select a remote device, and then click **Delete**.
- Batch delete:
 - ◇ Click , device list displays check box for you to select multiple remote devices.
Click  to delete the selected devices.
 - ◇ On the device list, click one remote device, press Ctrl to select other remote devices and then click  to delete them.
 - ◇ On the device list, click one remote device, press Shift and then click another remote device to select all remote devices between these two, and then click  to delete them.
 - ◇ On the **Device List** interface, select multiple remote devices, and then click **Delete**.

8.2.2.8 Modifying Device Password

Modify passwords of connected devices.



You can only modify devices successfully connected to IVSS via private protocol.

Step 1 Click , or click  on the configuration interface, and then select **DEVICE**.

The **DEVICE** interface is displayed. See Figure 8-26.

Figure 8-26 Device management

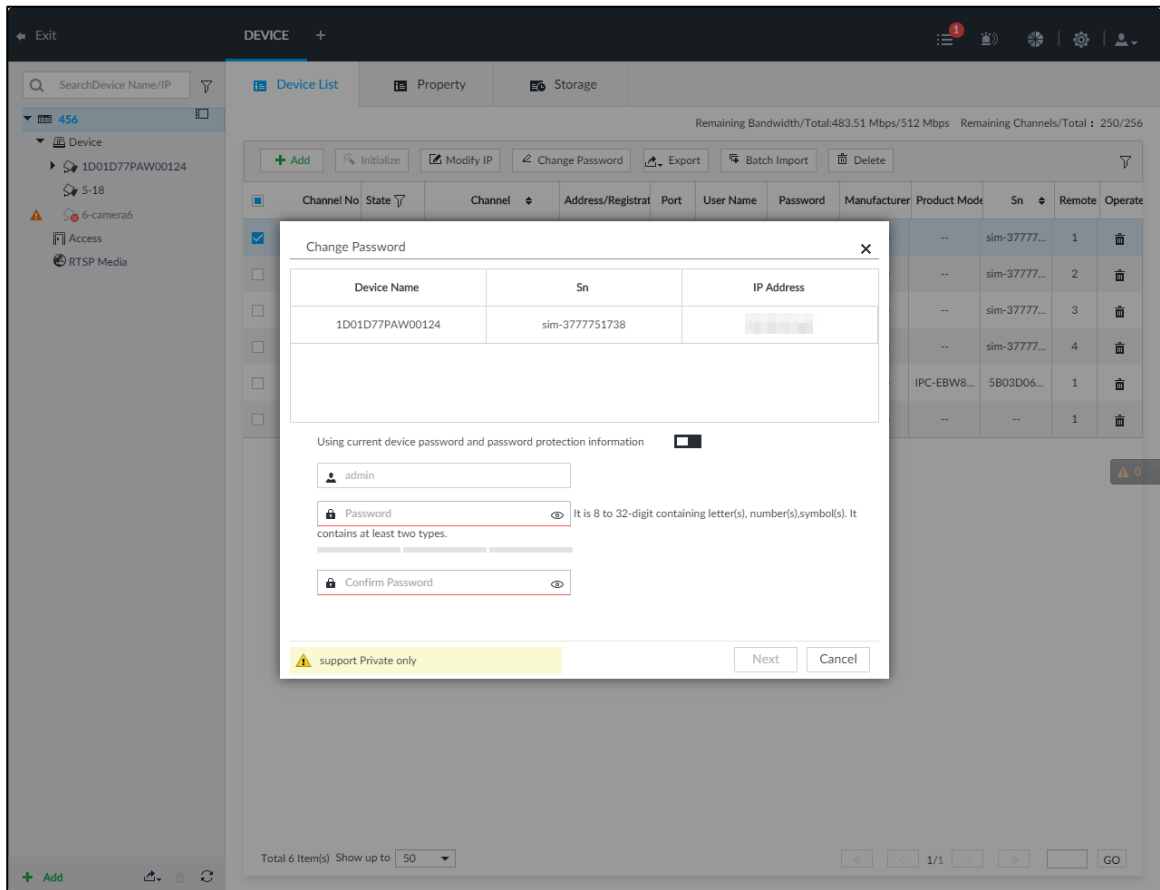
The screenshot displays the 'DEVICE' management interface. On the left, there is a sidebar with a search bar and a tree view showing 'IVSS' and 'Device' categories. The main area features a 'Device List' tab with a table of 17 devices. The table columns are: Channel No, State, Channel, Address/Registrar, Port, User Name, Password, Manufacturer, Product Model, Sn, Remote, and Operate. The 'State' column shows green dots for all devices. The 'Channel' column lists various identifiers, including 'camera1' through 'camera4'. The 'Port' column shows values like 37777, 37715, and 10000. The 'User Name' column is 'admin' for all. The 'Password' column is masked with asterisks. The 'Manufacturer' column is 'Private' for all. The 'Product Model' column shows various identifiers. The 'Sn' column shows serial numbers. The 'Remote' column shows values like 1, 2, 3, 4. The 'Operate' column shows a trash icon for each device. At the bottom of the table, it says 'Total 17 Item(s) Show up to 20'. There are also navigation buttons and a 'GO' button.

Channel No	State	Channel	Address/Registrar	Port	User Name	Password	Manufacturer	Product Model	Sn	Remote	Operate
1	●			37777	admin	*****	Private		4A05AC5...	1	🗑
2	●			37715	admin	*****	Private		sim-37715...	1	🗑
3	●			37715	admin	*****	Private		sim-37715...	2	🗑
4	●			37715	admin	*****	Private		sim-37715...	3	🗑
5	●			37715	admin	*****	Private		sim-37715...	4	🗑
6	●			37777	admin	*****	Private		1J012FEA...	1	🗑
7	●			37777	admin	*****	Private		5C0707AP...	1	🗑
8	●			37777	admin	*****	Private		5C0707AP...	2	🗑
9	●			37777	admin	*****	Private		5C0707AP...	1	🗑
10	●			37777	admin	*****	Private		4K02337Y...	1	🗑
11	●			37777	admin	*****	Private		4K02337Y...	2	🗑
12	●	camera1		10000	admin	*****	Private	--	sim-37777...	1	🗑
13	●	camera2		10000	admin	*****	Private	--	sim-37777...	2	🗑
14	●	camera3		10000	admin	*****	Private	--	sim-37777...	3	🗑
15	●	camera4		10000	admin	*****	Private	--	sim-37777...	4	🗑
16	●	camera1		37716	admin	*****	Private	--	sim-37777...	1	🗑
17	●	camera2	10.172.33.21	37716	admin	*****	Private	--	sim-37777...	2	🗑

Step 2 Select a remote device and then click **Change Password**.

The **Change Password** interface is displayed. See Figure 8-27.

Figure 8-27 Modify password



Step 3 Keep Using current device password and password protection information disabled.

means that the function is disabled.

Step 4 Enter the new password, and then confirm it as required.

Step 5 Click **Next** button.

The result of password modification is displayed.

Step 6 Click **OK**.

Step 7 (Optional) On the **Device List** interface, double-click the device name, and then you can modify device name.

8.3 Network Management



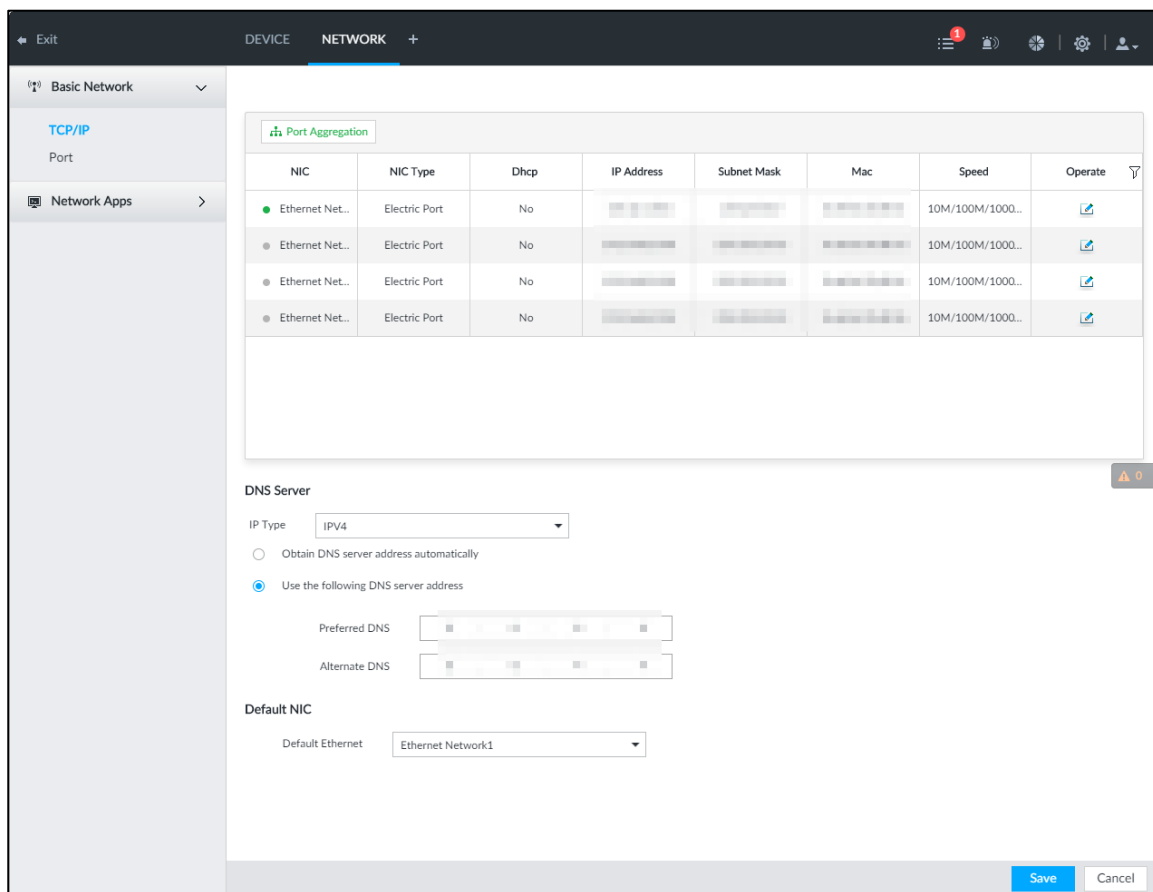
Click  or click  on the configuration interface, select **NETWORK**. The **NETWORK** interface is displayed. See Figure 8-28. You can set basic network parameters and application.

Figure 8-28 Network management



8.3.1 Basic Network

Set basic network parameters of the device, such as IP address, port aggregation and port number, to connect with other devices in the network.

8.3.1.1 Configuring IP Address

Set device IP address, DNS server information and other information according to network planning.



Device has 4 Ethernet ports by default. Make sure that at least one Ethernet port has connected to the network before you set IP address.

Step 1 Click  or click  on the configuration interface, and then select **NETWORK >**

Basic Network > TCP/IP.

The **TCP/IP** interface is displayed. See Figure 8-29.




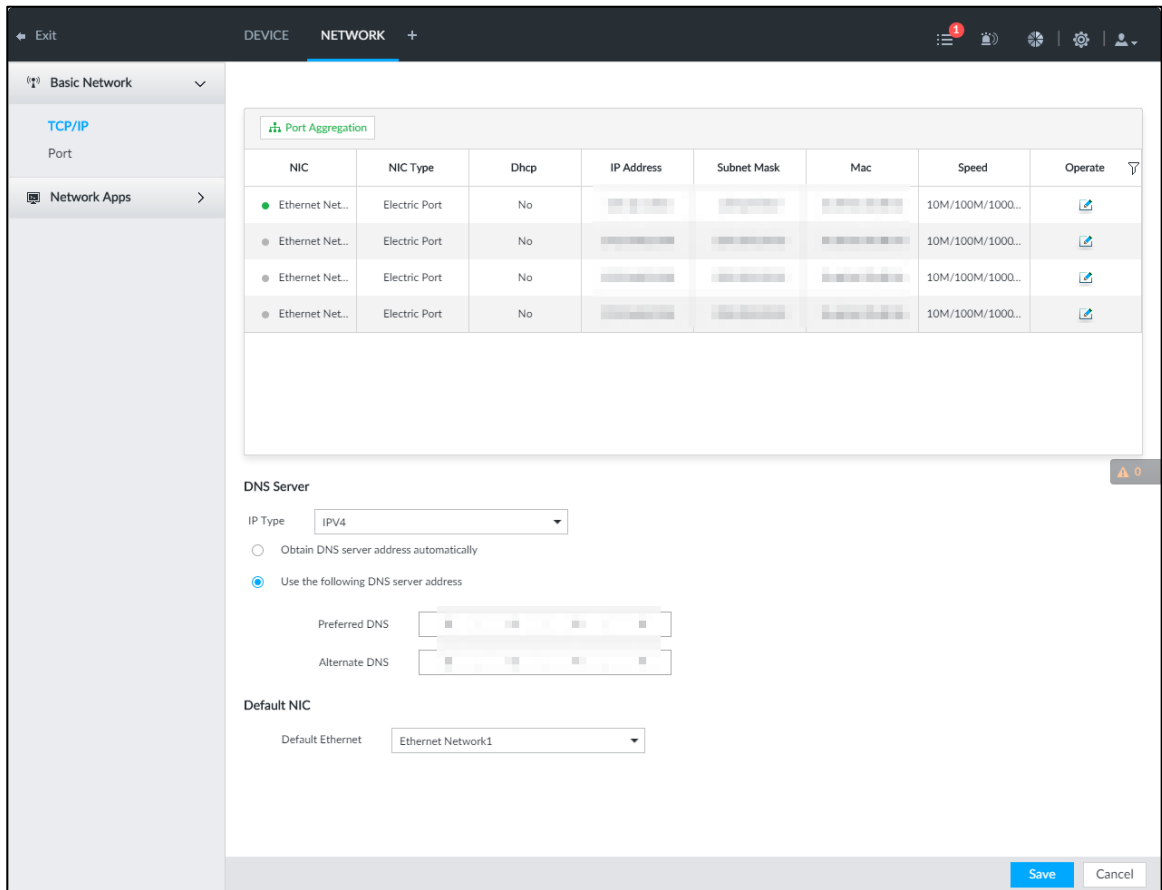

Click  to view the NIC parameter information.

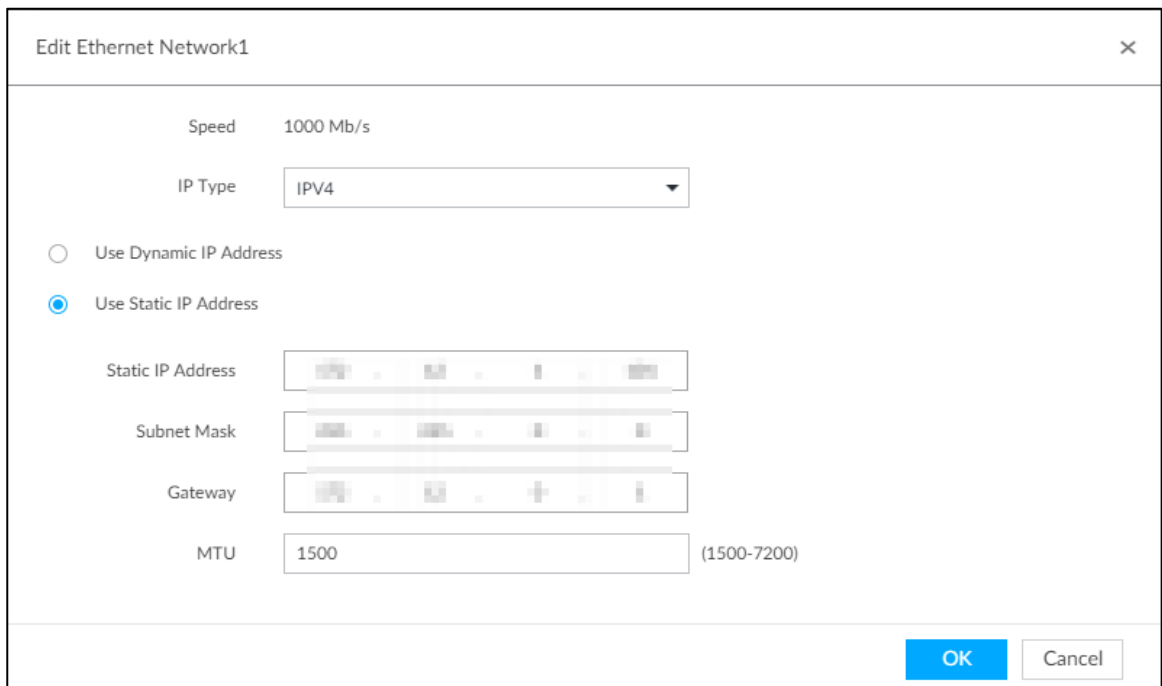
Figure 8-29 TCP/IP



Step 2 Click  of the corresponding NIC.


The **Edit Ethernet Network** interface is displayed. See Figure 8-30.

Figure 8-30 Edit Ethernet network



Step 3 Set parameters. For details, see Table 8-7.

Table 8-7 TCP/IP parameters description

Parameters	Description
Speed	Current NIC max network transmission speed.
IP Type	Select IPv4 or IPv6.
Use Dynamic IP Address	When there is a DHCP server on the network, check the box to use dynamic IP address, system can allocate a dynamic IP address to the device. There is no need to set IP address manually.
Use Static IP Address	Check the box to use static IP address. Set static IP address, subnet mask and gateway. Set a static IP address for the device.
MTU	<p>Set NIC MTU value. The default setup is 1500 Byte.</p> <p>We recommend you to check the MTU value of the gateway first and then set the device MTU value equal to or smaller than the gateway value. It is to reduce the packets slightly and enhance network transmission efficiency.</p>  <p>Changing MTU value might result in NIC reboot, network offline and affect current running operation. Please be careful!</p>

Step 4 Click **OK**.

Go back to **TCP/IP** interface.

Step 5 Set DNS server information.

You can select to get DNS server manually or enter DNS server information.



This step is compulsive if you want to use domain service.

- Check the box to auto get DNS server address, device can automatically get the DNS server IP address on the network.
- Check the box to use the following DNS server addresses, and then enter primary DNS and alternate DNS IP address.

Step 6 Set default NIC.

Select default NIC from the drop-down list.



Make sure that the default NIC is online.


Step 7 Click **Save**.

8.3.1.2 Port Aggregation

Bind multiple NIC to create one logic NIC and use one IP address for peripheral device. The bonded NIC can work as the specified aggregation mode to work. It enhances network bandwidth and network reliability.

System supports configuring load balance, fault tolerance, and link aggregation. See Table 8-8.

Table 8-8 Aggregation mode description

Aggregation mode	Description
Load balance	<p>Device has bonded several NICs at the same time and use one IP address to communicate with the external device. The bonded NICs are working together to bear the network load.</p> <p>The load balance mode adds the network throughput data amount and enhances network flexibility and availability. In this mode, the network is offline once all NICs break down.</p>
Fault-tolerance	<p>In this mode, device has bonded several NICs and set one NIC as the master card and the rest NICs are the alternative NICs. Usually, only the master NIC card is working. System can automatically enable other alternate cards to work when the master card breaks down.</p> <p>Fault-tolerance is a network mode to enhance NIC reliability. In this mode, the network is offline once all NICs break down.</p>
Link aggregation	<p>Device has bonded several NICs and all NICs are working together to share the network load. System allocates data to each NIC according to your allocated strategy. Once the system detects that one NIC breaks down, it stops sending data with this NIC, and then system transmits the data among the rest NICs. System calculates transmission data again after malfunctioning NIC resumes work.</p> <p>In this mode, the network is offline once all bonded NICs are malfunctioning.</p> <p></p> <p>Make sure that the switch supports link aggregation and you have set the link aggregation mode.</p>

8.3.1.2.2 Binding NIC

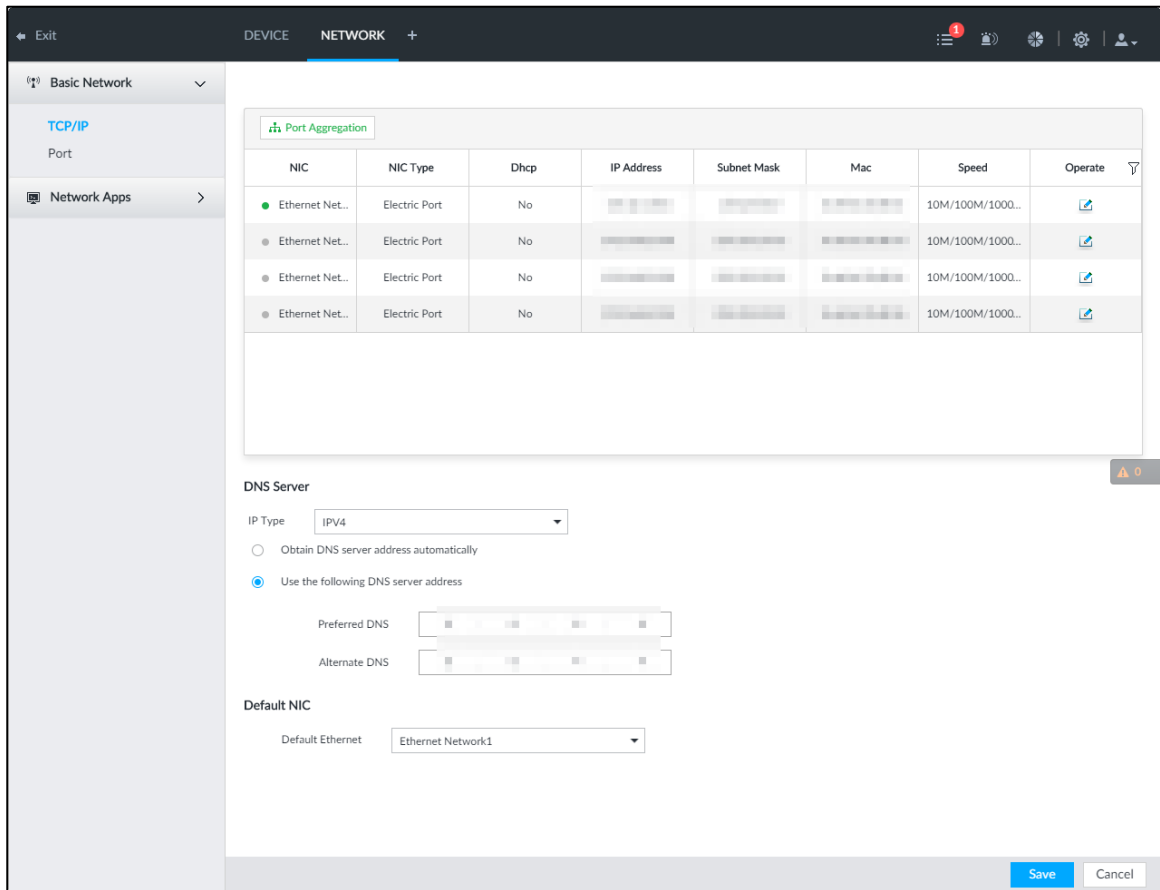
System supports load balance, fault-tolerance, and link aggregation. Select bind mode according to your actual requirements.

Step 1 Click  or click  on the configuration interface, and then select **NETWORK >**

Basic Network > TCP/IP.

The **TCP/IP** interface is displayed. See Figure 8-31.

Figure 8-31 TCP/IP

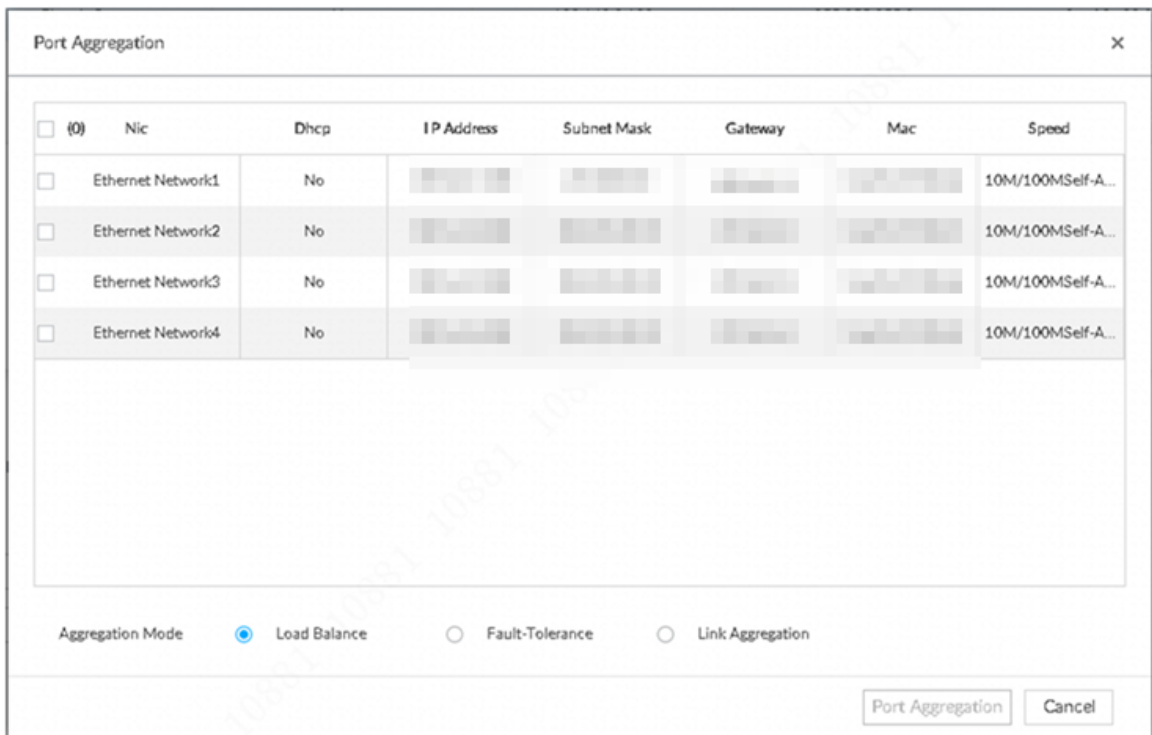


Step 2 Bind NICs.

- 1) Click **Port Aggregation**.

The **Port Aggregation** interface is displayed. See Figure 8-32.

Figure 8-32 Port aggregation



- 2) Select the NICs you want to bind.
- 3) Select an aggregation mode.

4) Click **Port Aggregation**.

The corresponding setting interface is displayed. See Figure 8-33.




The setting interface varies depending on the aggregation mode you have selected. Figure 8-33 is the load balance setting interface. For the other two modes, the actual interface shall prevail.

Figure 8-33 Edit load balance

5) Set parameters. For details, see Table 8-9.

Table 8-9 TCP/IP parameters description

Parameters	Description
Speed	Maximum network transmission speed of current NIC.
IP Type	Select IPv4 or IPv6.
Use Dynamic IP Address	When there is a DHCP server on the network, check the box to use dynamic IP address. System can allocate a dynamic IP address to the device. There is no need to set IP address manually.
Use Static IP Address	Check the box to use static IP address. Set static IP address, subnet mask and gateway. Set a static IP address for the device.

Parameters	Description
MTU	<p>Set NIC MTU value. The default setup is 1500 Byte.</p> <p>We recommend you to check the MTU value of the gateway first and then set the device MTU value equal to or smaller than the gateway value. It is to reduce the packets slightly and enhance network transmission efficiency.</p>  <p>Changing MTU value might result in NIC reboot, network offline and affect current running operation. Please be careful!</p>

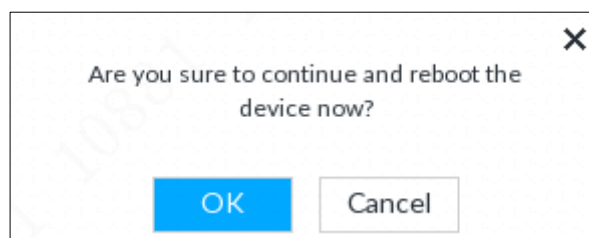
6) Click **OK**.

Go back to **TCP/IP** interface.

Step 3 Click **Save**.

System pops up a confirmation box. See Figure 8-34.

Figure 8-34 Confirmation



Step 4 Click **OK** to save the configuration.

The binding card information becomes activated after reboot operation.

8.3.1.2.3 Cancelling Binding NIC

Cancel port aggregation and allow the bonded NICs to work as independent card.

Step 1 Click  or click  on the configuration interface, and then select **NETWORK >**

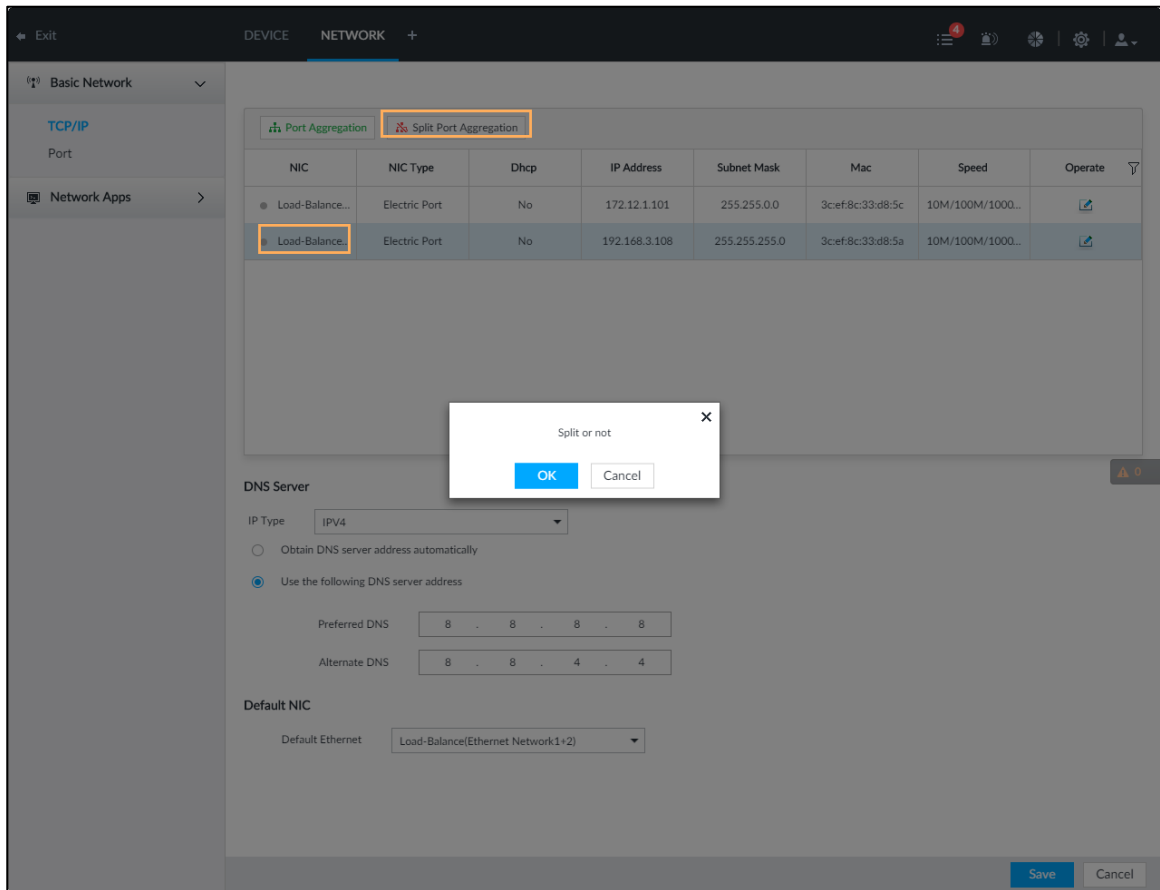
Basic Network > TCP/IP.

The **TCP/IP** interface is displayed.

Step 2 Select a bonded NIC.

The confirm dialogue box is displayed. See Figure 8-35.

Figure 8-35 Confirm



Step 3 Click **OK**.



System splits the bonded NIC.



After splitting NIC binding, the first NIC reserves the IP address configured during binding, while the rest NICs restore default IP addresses.

8.3.1.3 Setting Port Number

Set device port number.

Step 1 Click , or click  on the configuration interface, and then select **NETWORK >**

Basic Network > Port.

The **Port** interface is displayed. See Figure 8-36.

Figure 8-36 Port

Step 2 Set parameters. For details, see Table 8-10.



Log in again after modifying parameters except **Max Connection**.

Table 8-10 Connection setting parameters description

Parameters	Description
Max Connection	The allowable maximum clients accessing the Device at the same time, such as web, PCAPP, and Platform. Select a value between 1 and 128. The default value setting is 20.
TCP Port	Set according to the actual requirements. The default value is 37777. The value ranges from 1025 to 65535.
RTSP Port	Set according to the actual requirements. The default value is 554. The value ranges from 1 to 65535.
HTTP Port	Set according to the actual requirements. The default value is 80. The value ranges from 1 to 65535. If the value you set is not 80, please add the port number after the IP address when you are using browser to login the device.
HTTPS Port	Set according to the actual requirements. The default value is 443. The value ranges from 1 to 65535.
UDP Port	Set according to the actual requirements. The default value is 37778. The value ranges from 1025 to 65535.

Step 3 Click **Save**.

System reboots corresponding service of the port.

8.3.2 Network Apps



Set device network parameters, so that system can connect to other devices.

8.3.2.1 P2P

P2P is a peer to peer technology. You can scan the QR code to download cellphone APP without DDNS service or the port mapping or installing the transmission server. After register the device to the APP, you can view the remote video, playback record file and so on.

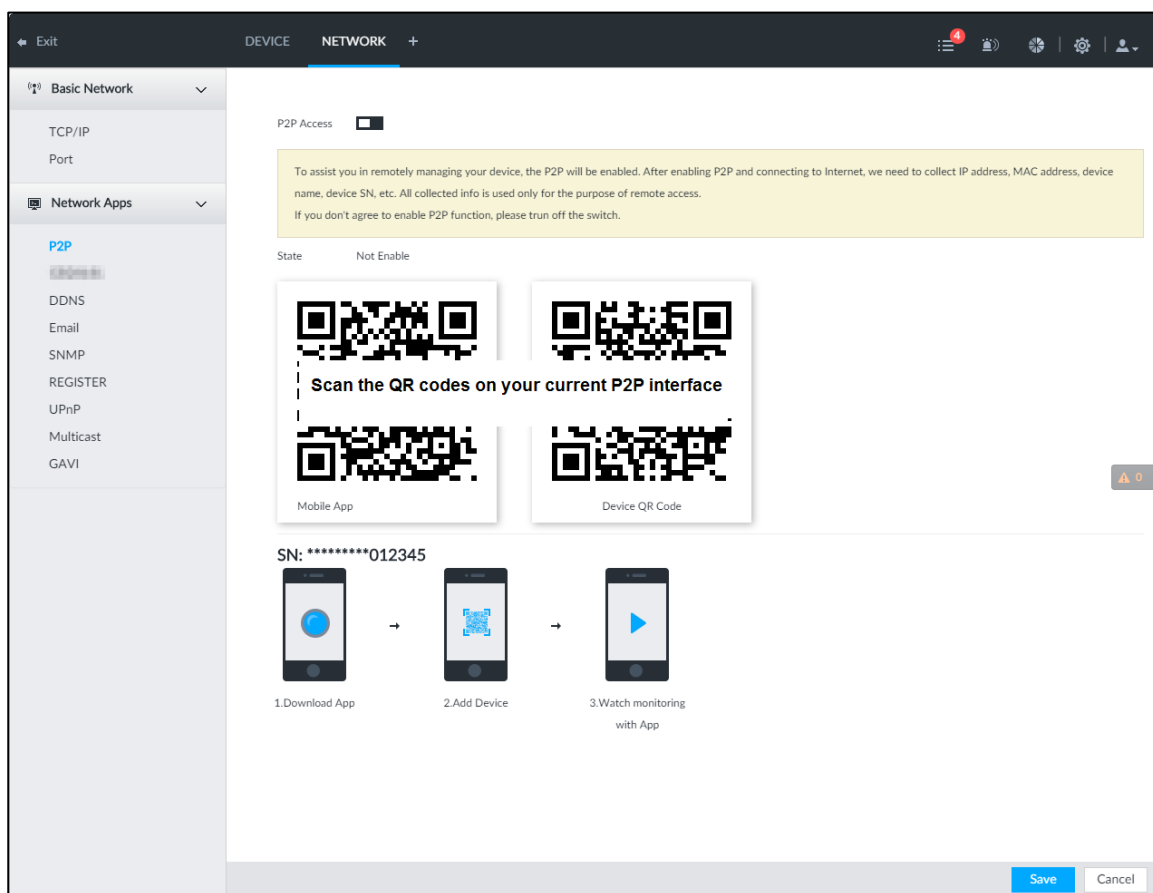



- Make sure that the system has connected to the network. Otherwise, the P2P function is null.
- When using the P2P function, we will collect device information such as IP address, MAC address, name and serial number. The collected information is only used for remote access.

Step 1 Click , or click  on the configuration interface, and then select **NETWORK > Network Apps> P2P**.

The **P2P** interface is displayed. See Figure 8-37. Scan the QR code on the actual interface.

Figure 8-37 P2P



Step 2 Click  to enable P2P function.

Step 3 Click **Save**.

After the configuration, you can register a device to the APP to view remote video, playback record file, and so on. See corresponding cellphone APP for detailed information.



After successfully connected to the P2P, the status displayed as Success.

8.3.2.2 DDNS

After setting DDNS parameters, when IP address of IVSS changes frequently, the system dynamically updates the relation between domain name and IP address on DNS server. You can use domain name to remotely access IVSS, without need to note down IP address.

Preparation

Confirm whether IVSS supports the DDNS Type and log in the website provided by the DDNS service provider to register the information such as domain from PC located in the WAN.



After you have registered and logged in the DDNS website successfully, you can view the information of all the connected devices under this user name.

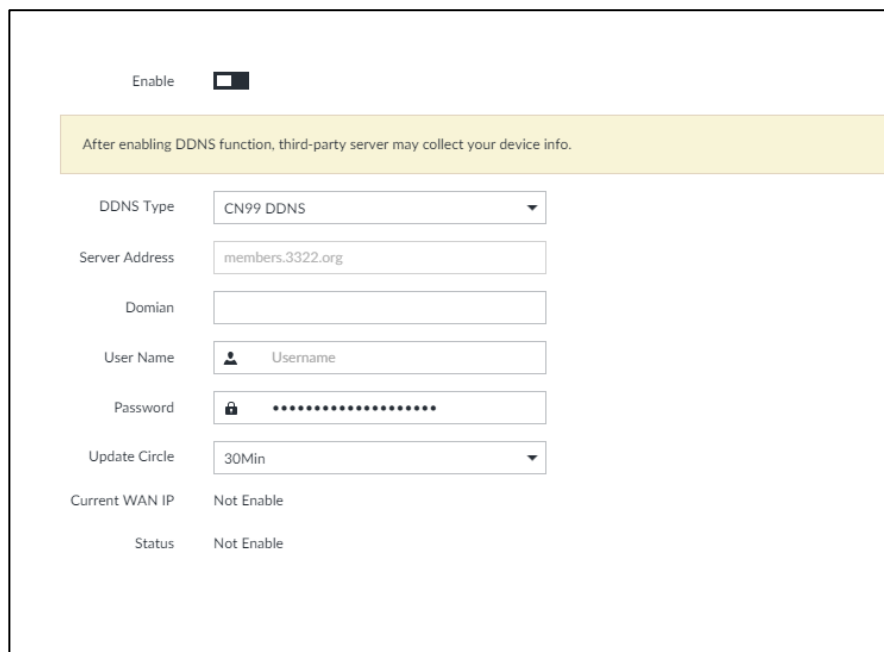
Procedure


Step 1 Click , or click  on the configuration interface, and then select **NETWORK >**

Basic Network > DDNS.

The **DDNS** interface is displayed. See Figure 8-38.

Figure 8-38 DDNS



Step 2 Click  to enable DDNS function.



After enabling DDNS function, the third-party server might collect your device information. Pay attention to privacy security.

Step 3 Set the corresponding parameters. For details, see Table 8-11.

Table 8-11 DDNS setting parameters description

Parameters	Description
DDNS Type	Name and address of DDNS service provider.
Server Address	<ul style="list-style-type: none"> • DynDNS DDNS: members.dyndns.org • NO-IP DDNS: dynupdate.no-ip.com • CN99 DDNS: members.3322.org
Domain	The domain name for registering on the website of DDNS service provider.
Username	Enter the user name and password obtained from DDNS service provider.
Password	You need to register (including user name and password) on the website of DDNS service provider.
Update Circle	Enter the amount of time that you want to update the DDNS.
Current WAN IP	Displays the WAN IP address of IVSS.
Status	Displays DDNS registration result or update status.

Step 4 Click **Save**.

After successful configuration, enter domain name in address bar of the browser or PCAPP, and press Enter key to access the IVSS.

8.3.2.3 Email

Configure email information, and enable alarm linked email. When NVR has alarm events, the system automatically sends emails to the user.



Device data will be sent to specific servers after the email function is enabled. Be cautious.

Step 1 Click , or click  on the configuration interface, and then select **NETWORK >**

Network Apps > Email.


The **Email** interface is displayed. See Figure 8-39.

Figure 8-39 Configuring Email

Step 2 Click to enable the email function.

Step 3 Set parameters.

Table 8-12 EMAIL parameter description

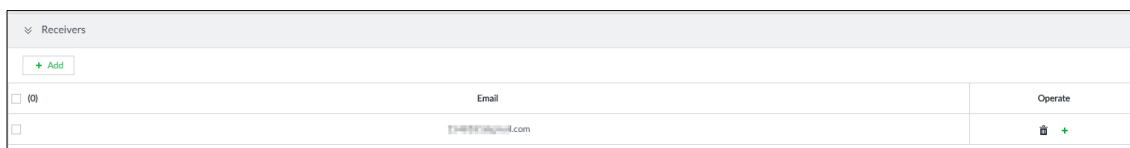
Parameters	Description
Email Server	Select email server type, including Customize, Gmail, Hotmail, and Yahoo.
Server Address	Enter email server address.
Encryption	Set the encryption type of email server, such as NONE, SSL, and TLS.  You are recommended to select TLS. Other encryption methods might not be safe.
Port	Enter the port number of email server. For details, see.
User name and password	Enter the configured user name and password of Email server. For details, see.

Step 4 Add the information of mail receiver.

- 1) Click **Add**.
The **Add** interface is displayed.

2) Enter a receiver email address. See Figure 8-40.

Figure 8-40 Email address



3) Click **Add** or to add other receiver email address.

- Click to delete the added receiver.
- Select a receiver. The **Delete** button is displayed. Click **Delete** button to delete the selected receiver.

Step 5 Click **Save**.

Step 6 (Optional) Test the email sending function.

1) In **Test Mail**, select or enter a receiver email address.

2) Click **Send**.

- When the configuration is correct, the system pops up a message of success, and the receiver will receive the test mail.
- Otherwise, the system pops up a message of failure, and the receiver will not receive the test mail.

8.3.2.4 SNMP

After setting SNMP (Simple Network Management Protocol) and successfully connecting devices through relevant software tools such as MIB Builder, and MG-SOFT MIB Browser, you can directly manage and monitor devices on software tools.



- Install SNMP device monitoring and management tools, such as MIB Builder and MG-SOFT MIB Browser.
- Obtain the MIB file corresponding to the current version from technical support.

Step 1 Click , or click on the configuration interface, and then select **NETWORK > Network Apps > SNMP**.

The **SNMP** interface is displayed. See Figure 8-41.

Figure 8-41 SNMP (1)

The image shows a configuration window for SNMP. At the top left, there is a collapse icon and the text 'SNMP'. Below this, there are several configuration options:

- Enable:** A checkbox that is currently checked.
- SNMP Version:** A dropdown menu with 'SNMP V1/V2' selected.
- Port:** A text input field containing '161'.
- Read Community:** An empty text input field.
- Write Community:** An empty text input field.
- Trap Server:** A text input field containing three dots '...'.
- Trap Port:** A text input field containing '162', with a small '(1-65535)' label to its right.

In the bottom right corner of the window, there is a small grey box containing a warning icon and the number '0'.

Step 2 Click to enable the function.

Step 3 Select SNMP version.

- If you have selected SNMP V1/V2, see Figure 8-41.





SNMP V1/V2 has security risks. You are recommended to use SNMP V3.


- If you have selected SNMP V3, see Figure 8-42.

Figure 8-42 SNMP(2)

Step 4 Set parameters. For Trap server address, enter the IP address of the PC that has MG-SOFT MIB Browser. Keep the other parameters as default. For detailed description, see Table 8-13.

Table 8-13 SNMP parameters



Parameters	Description
Port	Listening port of agent programs on the device.
Read Community, Write Community	Read or Write Community supported by the agent programs.  The name can only contain numbers, letters, underscores, and middle lines.
Trap Server	The destination address of Trap information sent by the agent program.
Trap Port	The destination port of Trap information sent by the agent program.
Read Only User	Set the username the read-only user. The read-only user can only have the read-only permission.  The name can only contain numbers, letters, and underscores.

Parameters	Description
Read Authentication Type	You can select MD5 or SHA. It is MD5 by default.
Read Authentication Password	The password must contain at least 8 digits.
Read Encryption Type	CFB-AES by default.
Read Encryption Password	The password must contain at least 8 digits.
Read/Write User	<p>The username is <i>private</i> by default. If you log in using this username, you have the read-and-write permission.</p>  <p>The name can only contain numbers, letters, and underscores.</p>
R/W Authentication Type	You can select MD5 or SHA. It is MD5 by default.
R/W Authentication Password	The password must contain at least 8 digits.
R/W Encryption Type	CFB-AES by default.
R/W Encryption Password	The password must contain at least 8 digits.

Step 5 Click **Save**.

8.3.2.5 Register

Register the device on designated proxy server, and client software visits the device through the proxy server.

Step 1 Click , or click  on the configuration interface, and then select **NETWORK > Network Apps > Register**.

The **REGISTER** interface is displayed. See Figure 8-43.

Figure 8-43 Register

Step 2 Click to enable the function.

Step 3 Set parameters. For details, see Table 8-14.

Table 8-14 Register

Parameters	Description
IP Type	Select IP address of server for registration.
Server	In the Server box, enter the IP address of server for registration.
Port	Enter the port number of the server for registration.
Device ID	Enter Device ID to identify IVSS uniquely. Device ID shall be consistent with server configuration.

Step 4 Click **Save**.

8.3.2.6 UPnP



Through the UPnP (Universal Plug and Play) protocol, you can establish a mapping relationship between the LAN and the WAN, the WAN user can use the WAN IP address to directly access the device in the LAN.



Device services and ports will be mapped to the public network after UPnP is enabled. Be cautious.

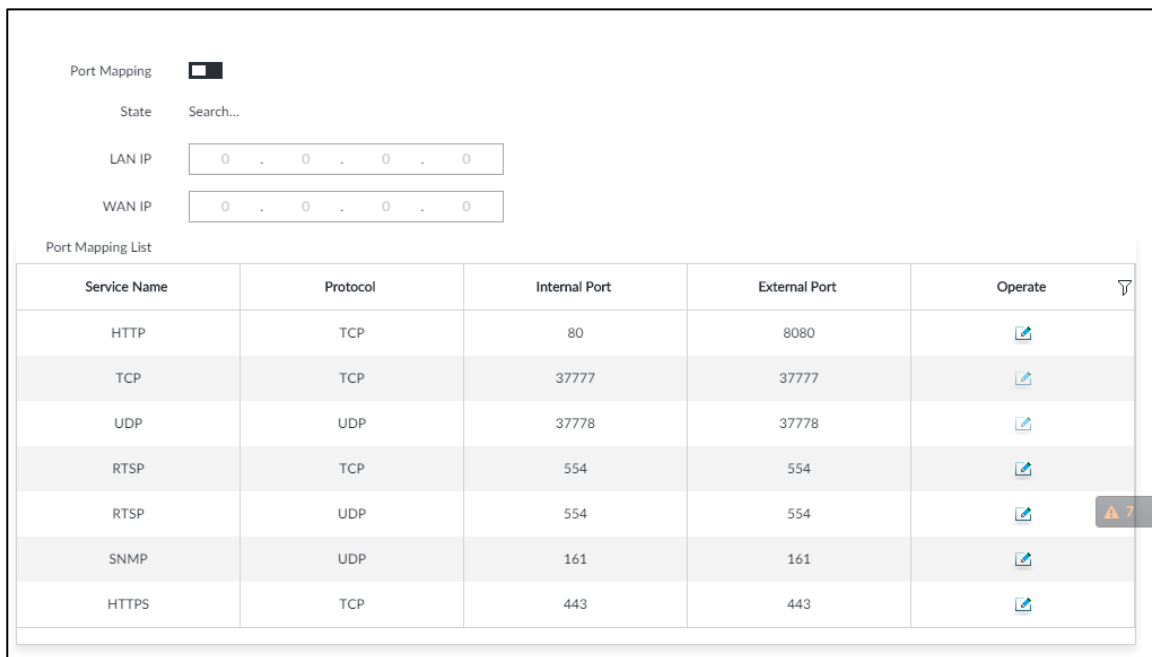


- Make sure that your PC has UPnP network services installed.
- Log in to the router and set the WAN port IP address of router.
- Enables the UPnP function on the router.
- Connect the device to the router LAN (Local Area Network, LAN) port.
- Select **NETWORK >Basic Network >TCP/IP**, and then set the IP address to be the private-network IP of the router, or select DHCP to automatically obtain the IP address.

Step 1 Click , or click  on the configuration interface, and then select **NETWORK > Network Apps > UPnP**.





The **UPnP** interface is displayed. See Figure 8-44.


Figure 8-44 UPnP



Step 2 Set parameters. For details, see Table 8-15.

Table 8-15 UPnP parameters

Parameters	Description
Port Mapping	Click  to enable UPnP.
State	The status of port mapping.
LAN IP	The LAN IP address of router.  The IP address is automatically obtained after the mapping succeeds.
WAN IP	The WAN IP address of router.  The IP address is automatically obtained after the mapping succeeds.
Port Mapping List	The list is consistent with the UPnP port mapping list on the router. <ul style="list-style-type: none"> Internal Port: The IVSS port to be mapped on the router. External Port: The WAN port of the internal port.  <ul style="list-style-type: none"> When setting the external port, use the ports between 1024 and 5000, and do not use the well-known ports 1 to 255 and the system ports 256 to 1023, so as to avoid conflicts. When there are multiple devices within the LAN, properly plan the port mapping to avoid conflicts of WAN ports.. When making a port mapping, make sure that the port you are mapping is not occupied or restricted. The TCP/UDP WAN and LAN ports must be consistent and cannot be modified.



Parameters	Description
Modification	Click  , and then you can modify the external port.

Step 3 Click **Save**.

Enter *http://WAN IP: WAN port number* in the browser to access the device with the corresponding port number in the router network.

8.3.2.7 Multicast

When multiple users are viewing live video of the same device at the same time, it might cause failure due to limited bandwidth. To solve this problem, you can set a multicast IP address (224.0.0.0–239.255.255.255) for the Device.

Step 1 Click , or click  on the configuration interface, and then select **NETWORK > Network Apps > Multicast**.

The **Multicast** interface is displayed. See Figure 8-45.

Figure 8-45 Multicast



Step 2 Click  to enable multicast.

Step 3 Set parameters. See Table 8-16.

Table 8-16 Parameters

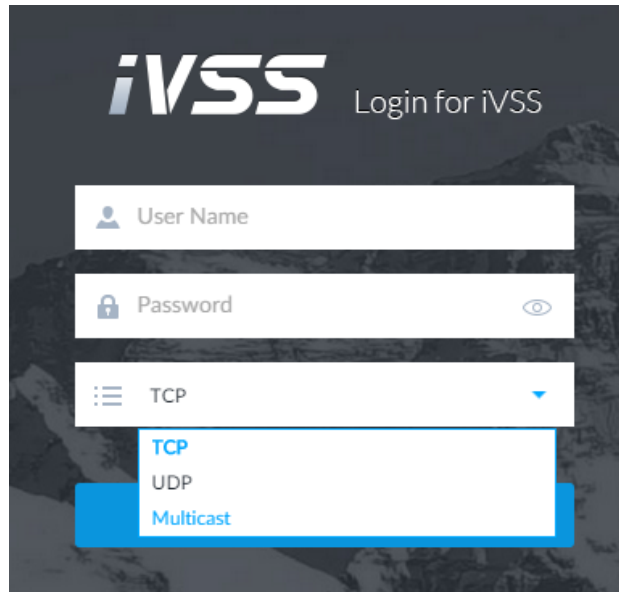
Parameters	Description
IP Address	Set the multicast IP address of the device(224.0.1.0–239.255.255.255).
Port	Set the multicast port (1025–65000).

Step 4 Click **Save**.

After configuring the multicast address and port, you can log in to the web interface or PCAPP client through the multicast protocol.



Take PCAPP for example. On the login interface of PCAPP, select **Multicast** as the login type. See Figure 8-46. The PCAPP client will automatically obtain the multicast address and join the multicast group. After login, you can view live videos through multicast protocol.

Figure 8-46 Log in through multicast



8.3.2.8 GAVI

The device is connected to the server supporting view database, and after the connection, the server can collect information from the device, which is divided into human, face, motor vehicle, non-motor vehicle and image.



Step 1 Click , or click  on the configuration interface, and then select **NETWORK > Network Apps > GAVI**.

The **GAVI** interface is displayed. See Figure 8-47.

Figure 8-47 GAVI

Step 2 Select view database config info, and enable it.

Configure 1 and Configure 2 refers to two platforms. The device can connect 2 servers at the same time.

-  indicates that the device is not connected to the platform server.
-  indicates that the device is connected to the platform server.



Step 3 Set parameters. See Table 8-17.

Table 8-17 Parameters


Parameters	Description
Server IP	Video database server IP.
Server Port	Video database server port. It is 80 by default. This port must be consistent with the server port.
Alive Interval	The interval of heartbeat between vide database and server. It is 90 seconds by default.
Max Alive TimeoutTimes	Set the number of heartbeat timeout times between the device and view database. After the defined the times of timeout, the device disconnects with the server. It is 3 times by default.
Device ID	The ID given by the server. IDs or devices are unique.
Account	Username and password of the view database server.
Password	
Platform Access	The access protocol between the device and platform server.
Registration Interval	The device keeps sending registration requests to the platform at the pre-defined interval if it failed to register for the first time. The registration interval is 30 seconds to 300 seconds.
Channel	Select a channel and set channel number for it.
Channel No.	Channel: For a multi-channel device, you can select the specific channels to collect information; for a single-channel device, the channel number is 0 bydefault. Channel No.: Set the number of channel, so as to differentiate the channels.
View Database Collection Object	Set the information types that the server needs to collect from the device through view database.

Step 4 Click **Save**.

8.4 Event Management

Click  or click  on the configuration interface, select **EVENT**. The **EVENT** interface is displayed. See Figure 8-48.

On the interface, configure alarm event, including alarm event of IVSS and remote device.

- Select the root node  in the resource tree on the left to set alarm event of the Device. See "8.4.1.11 Smart Tracking

Alarm is triggered when a tripwire or intrusion behavior is detected. If smart tracking action is configured, the PTZ camera automatically rotates to the target view to track it.



- Smart tracking is only available for AI by camera.
- Smart tracking is only available on the multi-sensor panoramic camera + PTZ camera.

On the event configuration interface, select Actions > **Smart Tracking** to enable the action.

- Local Device" for detailed information.
- Select remote device in the device tree on the left, to set alarm event of this remote device. See "8.4.3 Remote Device" for detailed information.







- The alarm event might be different depending on the model you purchased. The actual interface shall prevail.
-  means that the corresponding alarm event has been enabled.
-  means that AI by camera has been enabled;  means that AI by device has been enabled;  means that both have been enabled.

Figure 8-48 Event management

DEVICE INFO		Face	Video Metadata	Is	Vehicle	Video Detect
Channel No	State	Channel	Address/Registration ID			
1	●	4	10.10.10.100			✓
2	●	camera2	10.10.10.100			✓
3	●	camera3	10.10.10.100			✓
4	●	camera4	10.10.10.100			✓
5	●	18	10.10.10.100			
6	●	camera6	172.16.1.100			
7	●	camera7	172.16.1.100			
8	●	camera8	172.16.1.100			
9	●	camera9	172.16.1.100			
10	●	camera10	172.16.1.100			
11	●	camera11	172.16.1.100			
12	●	camera12	172.16.1.100			
13	●	camera13	172.16.1.100			
14	●	camera14	172.16.1.100			
15	●	camera15	172.16.1.100			
16	●	camera16	172.16.1.100			
17	●	camera17	172.16.1.100			
18	●	camera18	172.16.1.100			

8.4.1 Alarm Actions

System can trigger the corresponding actions when an alarm occurs.



The supported actions might be different depending on the model you purchased. The actual interface shall prevail.

On the alarm configuration interface, click **Actions** to display actions. See Table 8-18 for detailed information. Configure actions according to your actual need.


- After setting actions, click **Save** on the interface.
- After enabling actions, click  to disable the corresponding actions.

Table 8-18 Actions description

Actions	Description	Preparation
Record	The system links the selected remote device to record when there is a corresponding alarm event.	Remote device, such as IPC, has been added. See "5.4.2 Adding Remote Device" for detailed information.
Buzzer	The system activates a buzzer alarm when there is a corresponding alarm event.	–
Log	The system notes down the alarm information in the log when there is a corresponding alarm event.	–
Email	The system sends alarm email to all added receivers when there is corresponding an alarm event.	Email configuration has been completed. See "8.3.2.3 Email" for detailed information.
Snapshot	The system takes snapshots of the linked channel hen there is corresponding an alarm event.	–
Preset	The system links the selected remote device to rotate to the designated preset point when there is a corresponding alarm event.	PTZ device has been added, and preset point has been added. See "5.4.2 Adding Remote Device" for detailed information.
Local Alarm Output	When there is an alarm, system can trigger the corresponding device to generate alarm.	IVSS is connected with alarm output device. See "3.4.1.4 Alarm Output."
IPC Alarm Output Settings	When there is an alarm, system can trigger the corresponding device to generate alarm.	IPC has been added, and IPC is connected with alarm output device. See "5.4.2 Adding Remote Device" for detailed information.
Access	When there is an alarm, system can trigger the corresponding access control device to open door and close door.	See "5.4.2 Adding Remote Device" for detailed information.
Voice Prompt	When there is an alarm, system can play the selected audio file.	Audio function has been configured. See "9.1.5 Voice Management" for detailed information.
Smart tracking	Alarm is triggered when a tripwire or intrusion behavior is detected. If smart tracking action is configured, the PTZ camera automatically rotates to the target view to track it.	See "8.4.1.11 Smart Tracking."

8.4.1.1 Record

Enable record control function. The system links the selected remote device to record when there is corresponding alarm event.



Make sure that the remote device, such as IPC, has been added. See "5.4.2 Adding Remote Device" for detailed information.

Step 1 Click **Actions**, and then select **Record**.

The record setting interface is displayed. See Figure 8-49.

Figure 8-49 Record

Step 2 Set the time length of recording after the event moment.

Step 3 (Optional) Repeat Step 1–Step 2 to link multiple remote devices to record.

8.4.1.2 Buzzer

The system activates a buzzer alarm when there is corresponding alarm event.

Click **Actions** and select **Buzzer** to enable this function. See Figure 8-50.

Figure 8-50 Buzzer

8.4.1.3 Log

Enable the log function. The system notes down the alarm information in the log when there is corresponding alarm event.

Click **Actions** and select **Log** to enable this function. See Figure 8-51.

Figure 8-51 Log



When log function is enabled, after an alarm is triggered, click **+** on **LIVE** interface, select **MAINTAIN > Log > Event**.

8.4.1.4 Email

Enable email function. The system sends alarm email to all added receivers when there is corresponding alarm event.



Make sure that the Email configuration has been completed. See 8.3.2.3 Email for detailed information.

Click **Actions** and select **Email** to enable this function. See Figure 8-52.

Figure 8-52 Email



8.4.1.5 Preset

Set preset function. The system links the selected remote device to rotate to the designated preset point when there is corresponding alarm event.

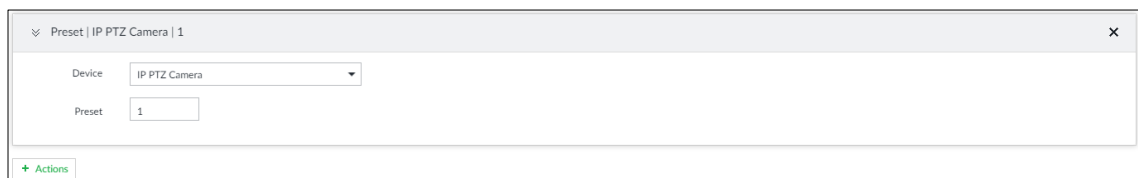


Make sure that the PTZ device has been added, and preset has been added. See "5.4.2 Adding Remote Device" for detailed information.

Step 1 Click **Actions** and select **Preset**.

The **Preset** interface is displayed. See Figure 8-53.

Figure 8-53 Preset



Step 2 Select PTZ device, and enter preset number.

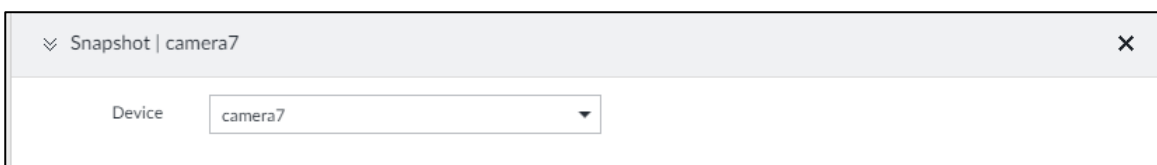
Step 3 (Optional) Repeat Step 1–Step 2, and link multiple PTZ devices to turn to designated presets.

8.4.1.6 Snapshot

Set the snapshot linkage action for alarms, so that once an alarm happens, it will triggered a snapshot of the alarm.

Click **Actions**, and then select **Snapshot**. The **Snapshot** interface is displayed. See Figure 8-54.

Figure 8-54 Snapshot action



8.4.1.7 Local Alarm Out

Set local alarm output. System can trigger the corresponding alarm event when an alarm occurs.

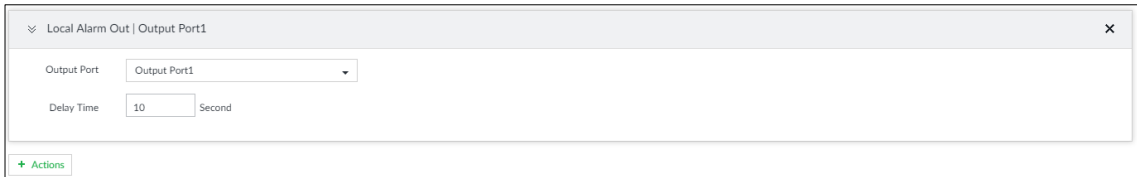


Make sure that IVSS is connected with alarm output device.

Step 1 Click Actions and select Local Alarm Out.

The **Local Alarm Out** interface is displayed. See Figure 8-55.

Figure 8-55 Local alarm out



Step 2 Select alarm output port.

You can select multiple alarm output ports.

Step 3 Set delay time.

Set a delay time. After alarm event is ended, alarm will end after the delay time. You can configure from 0 seconds through 300 seconds, and the default value is 10 seconds.

8.4.1.8 IPC Alarm Out

Set IPC alarm port output. System can trigger the corresponding alarm output device when an alarm occurs.

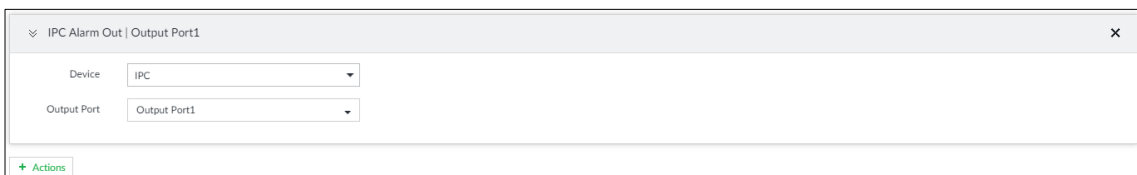


Make sure that the IPC has been added, and IPC is connected with alarm output device. See "5.4.2 Adding Remote Device" for detailed information.

Step 1 Click Actions and select IPC Alarm Out.

The **IPC Alarm Out** interface is displayed. See Figure 8-56.

Figure 8-56 IPC alarm output settings



Step 2 Select IPC and alarm output port.

You can select multiple alarm output ports.

Step 3 (Optional) Repeat Step 1–Step 2, and link multiple IPC alarm output devices.

8.4.1.9 Access

Set access control function. When there is an alarm, system can trigger the corresponding access control device to open door and close door.

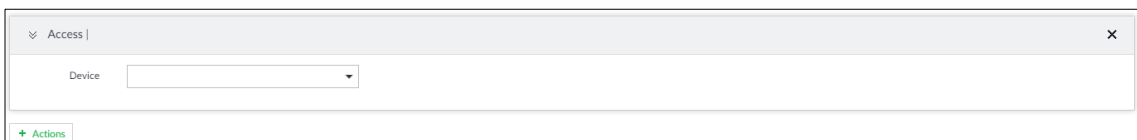


Make sure that access control device has been added. See "5.4.2 Adding Remote Device" for detailed information.

Step 1 Click **Actions** and select **Access**.

The **Access** setting interface is displayed. See Figure 8-57.

Figure 8-57 Access



Step 2 Select access control device.



Not all models support this function. The actual interface shall prevail.

Step 3 (Optional) Repeat Step 1–Step 2, and link multiple access control devices.

8.4.1.10 Voice Prompt

Set voice prompt function. When there is an alarm, system can play the selected audio file.



Make sure that the voice function has been configured. For details, see "9.1.5 Voice Management."

Step 1 Click **Actions** and select **Voice Prompt**.

The **Voice Prompt** interface is displayed. See Figure 8-58.

Figure 8-58 Voice prompt

The screenshot shows a configuration window for 'Voice Prompt'. It contains two main settings: 'File Name' and 'Delay Time'. The 'File Name' is a dropdown menu. The 'Delay Time' is a dropdown menu currently set to 'PlayTimes', with a text input field next to it containing the number '1'. At the bottom left of the window, there is a green button labeled '+ Actions'.

Step 2 In the **File Name** list, select the audio file that you want to play for this configured period.

Step 3 Set delay time.

- Play times: Select **Play Times** and enter the times to play the file. After the alarm event is ended, system will continue to play the voice file according to the play times.
- Duration: Select **Duration** and enter the delayed play duration. After the alarm event is ended, system will continue to play the voice file according to the duration.

8.4.1.11 Smart Tracking

Alarm is triggered when a tripwire or intrusion behavior is detected. If smart tracking action is configured, the PTZ camera automatically rotates to the target view to track it.



- Smart tracking is only available for AI by camera.
- Smart tracking is only available on the multi-sensor panoramic camera + PTZ camera.

On the event configuration interface, select **Actions > Smart Tracking** to enable the action.

8.4.2 Local Device



Set IVSS alarm event, including abnormal event, device offline alarm, AI plan, and local device alarm.

8.4.2.1 Abnormal Event

Set the alarm mode when an abnormal event occurs.

The Device supports HDD, storage error, network, AI module, fan and power fault alarm. For details, see Table 8-19.

Table 8-19 Abnormal event description

Name	Description
No HDD	System triggers an alarm when there is no HDD. It is enabled by default.
Storage error	System triggers an alarm in case of HDD error, RAID degrade, RAID broken, and storage pool error. It is enabled by default.
Storage space full	System triggers an alarm when the used storage space reaches the pre-defined threshold. It is disabled by default.  The alarm is valid only when the storage mode is set as Stop on the Local Hard Disk interface. For details, see "8.5.1.4 Setting Storage Strategy."
IP conflict	System triggers an alarm when its IP address conflicts with IP address of other device in the same LAN. It is enabled by default.
MAC conflict	System triggers an alarm when its MAC address conflicts with MAC address of other device in the same LAN. It is enabled by default.
Lock in	System triggers an alarm when an account login error has reached the threshold. At the same time, system locks current account. It is disabled by default.  Go to the Security interface to set account error threshold. See "8.6.3 Safety Protection" for detailed information.
AI module temp	When AI module temperature is higher than the specified value, system triggers an alarm. It is enabled by default.
AI module offline	When AI module and system is disconnected, system triggers an alarm. It is enabled by default.
Fan speed alarm	When IVSS fan speed is abnormal, system triggers an alarm. It is enabled by default.
Power fault	When IVSS power supply is abnormal, system triggers an alarm. It is disabled by default.

Here we take AI module temp for example. For other events, the setting steps are similar. See the actual interface for detailed information.

Step 1 Click , or click  on the configuration interface, and then select **EVENT**.

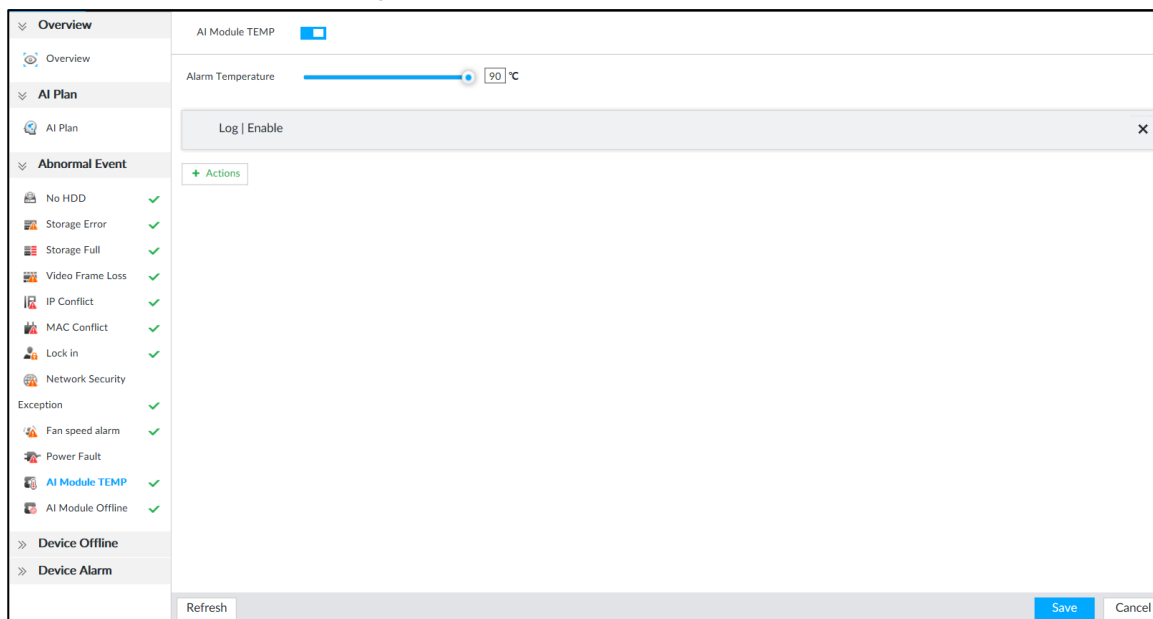
The **EVENT** interface is displayed.


Step 2 Select the root node in the device tree.

Step 3 Select Abnormal **Event** > **AI Module TEMP**.

The **AI Module TEMP** interface is displayed. See Figure 8-59.

Figure 8-59 AI module temp



Step 4 Click  to enable AI module temperature alarm function.

Step 5 Drag  to set alarm temperature threshold.



The above step is for AI module temperature alarm only.

Step 6 Click **Actions** to set alarm actions. See "8.4.1 Alarm Actions" for detailed information.

Step 7 Click **Save**.

8.4.2.2 Offline Alarm

Set IVSS network offline alarm. If you have not set offline alarm for a specified remote device, once the remote device is disconnect from the system, system adopts IVSS alarm strategy to trigger an alarm.

Step 1 Click , or click  on the configuration interface, and then select **EVENT**.

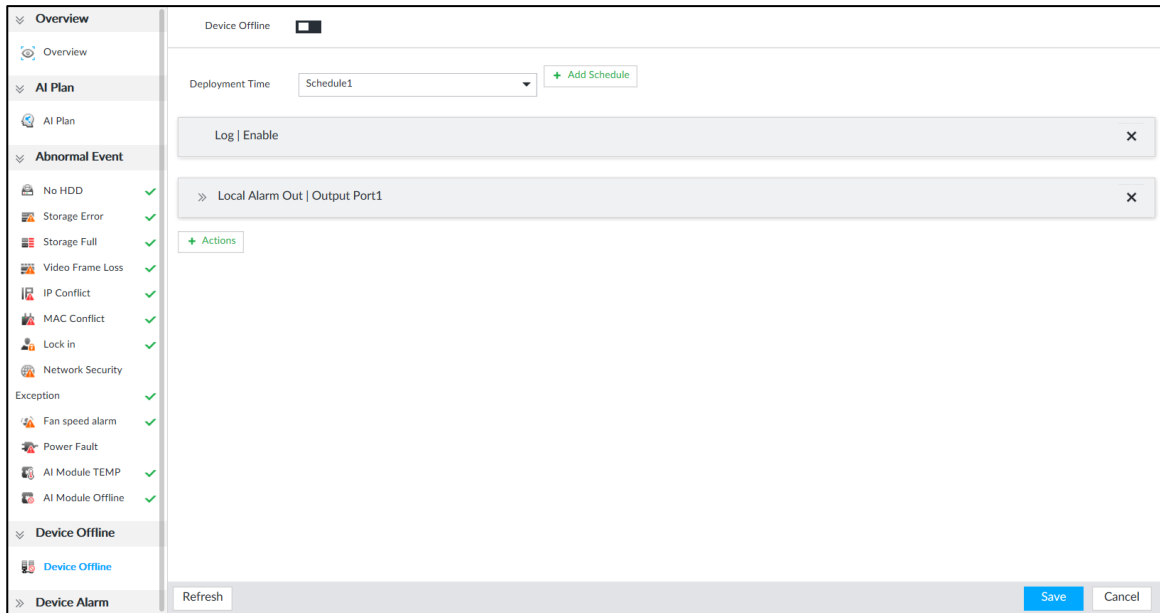
The **EVENT** interface is displayed.


Step 2 Select the root node in the device tree on the left.

Step 3 Select **Device Offline > Device Offline**.

The **Device Offline** interface is displayed. See Figure 8-60.

Figure 8-60 Offline alarm



Step 4 Click  to enable device offline alarm.

Step 5 Click **Deployment Time** to select schedule from the drop-down list.

After setting deployment period, system triggers corresponding operations when there is a motion detection alarm in the specified period.

- Click **View Schedule** to view detailed schedule settings.
- If the schedule is not added or the added schedule does not meet actual needs, click **Add Schedule**. See "8.8.4 Schedule" for detailed information.

Step 6 Click **Actions** to set alarm actions. See "8.4.1 Alarm Actions" for detailed information.

Step 7 Click **Save**.

8.4.2.3 Configuring AI Plan

Configure AI detection result display strategy of IVSS. If you have not set AI display settings for current remote device, the remote device inherits AI display mode of IVSS.

8.4.2.3.1 Viewing AI Plan

After adding remote device, on IVSS, obtain AI detection type and status of the remote device.

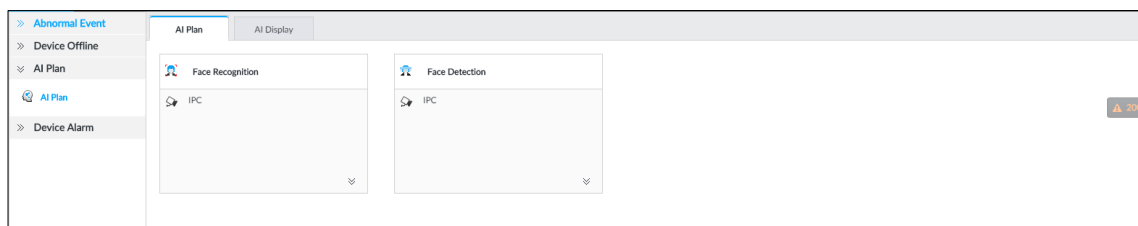
On the **EVENT** interface, select the root node in the device tree on the left. Select **AI Plan > AI Plan > AI Plan**. The **AI Plan** interface is displayed. See Figure 8-61.

After installing the AI module, and the remote device supports AI detection, and you have enabled the AI detection function, you can view channel name of the remote device on the corresponding AI detection panel.



 indicates that AI by camera is enabled;  indicates that AI by device is enabled

Figure 8-61 AI plan



8.4.2.3.2 Setting AI Display

Set the property that shall be displayed in rule box and feature property panel. View AI detection result through smart preview, and support to display face, human and vehicle.



Take the procedure of configuring face detection AI display as an example. For other AI detection functions, the procedures are similar.

Step 1 Click , or click  on the configuration interface, and then select **EVENT**.

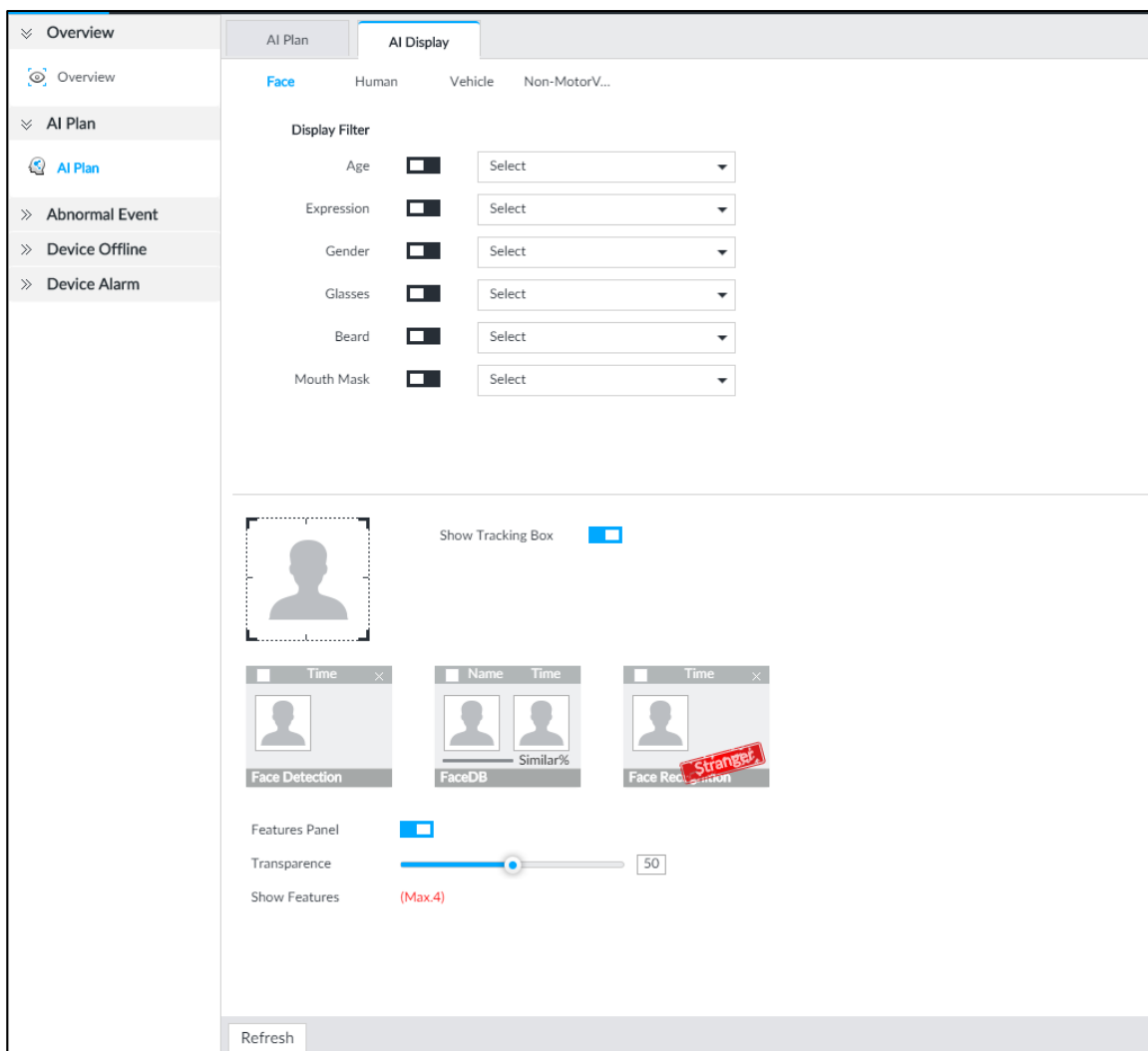
The **EVENT** interface is displayed.

Step 2 Select the root node in the device tree on the left.

Step 3 Select **AI Plan > AI Plan > AI Display > Face**.

The **Face** interface is displayed. See Figure 8-62.

Figure 8-62 Face



Step 4 Configure display filter information.

After setting filter criteria, only the qualified detection result will be displayed. For example, enable Age, and then select youth from the drop-down list. The tracking box and the features panel only display the human face of the youth age.

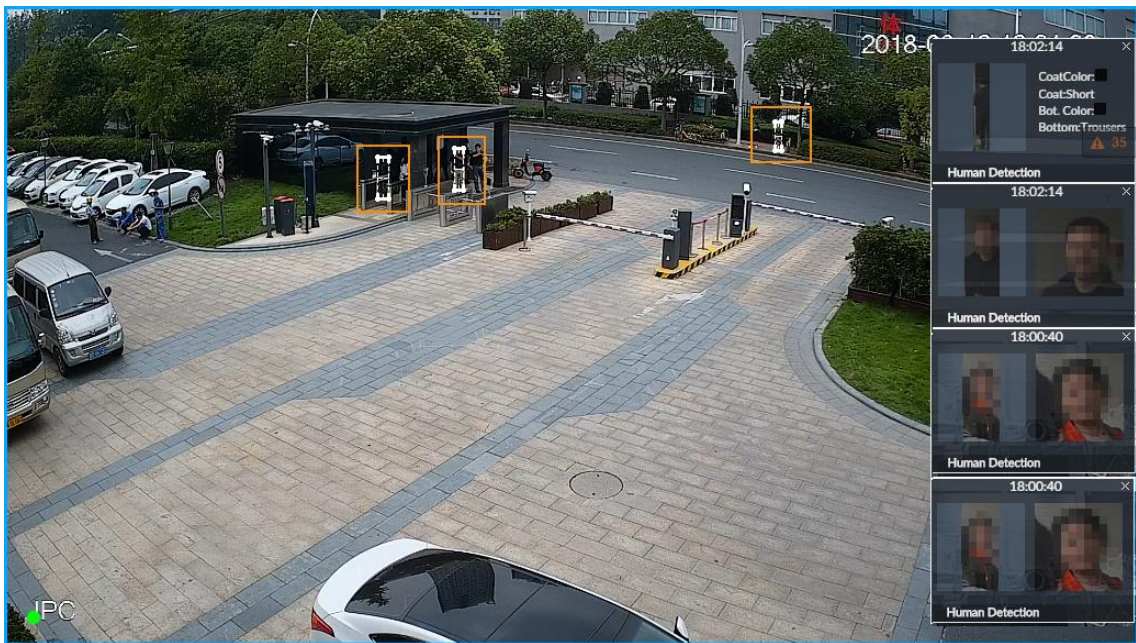
- 1) Click to enable corresponding filter type.
- 2) Set display filter criteria.

Click  to set the filter color.

Step 5 Click in the right of **Show Tracking Box** to enable.

After enabled, when the system detects face or human, tracking box will be shown beside the face or human in the view window. See Figure 8-63.

Figure 8-63 Tracking box



Step 6 Click in the right of **Features Panel** to enable, and select the features that shall be displayed on the **LIVE** interface.

After enabled, there is a features panel on the right side of the view window. See Figure 8-64.


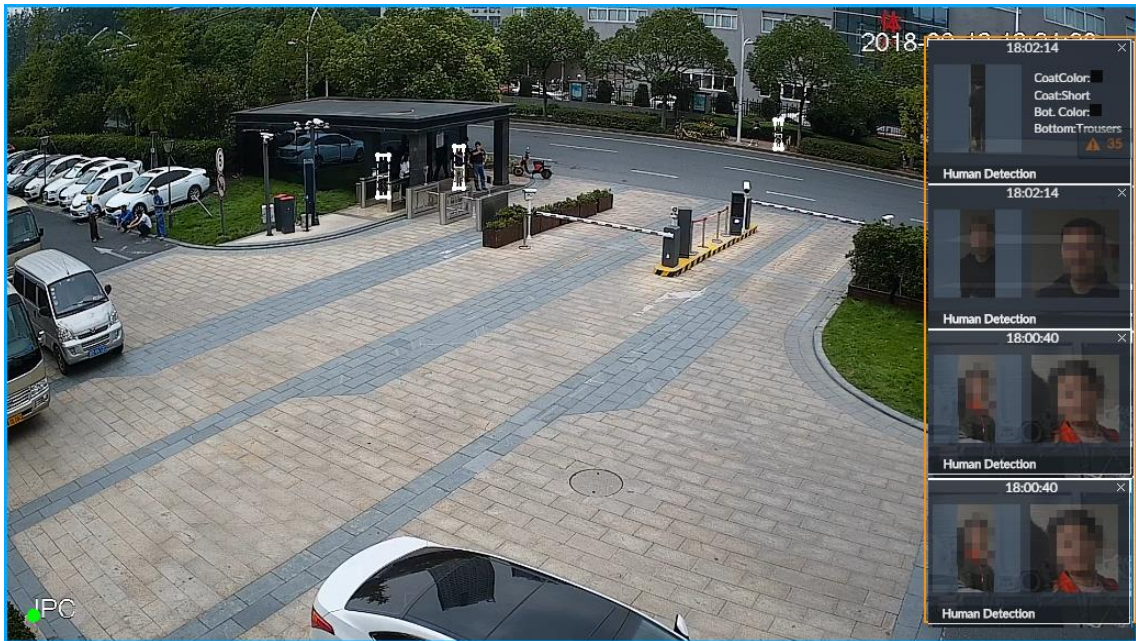
- Drag  to adjust features panel transparency. The higher the value, the more transparent the features panel.
- System supports maximum 4 features. System has checked four features by default. To select other features, cancel the selected features, and then select the ones you need.
- Click to display the features panel on the **LIVE** interface, including face detection panel, stranger panel and face DB panel.

Figure 8-64 Features panel



Step 7 Click **Save**.

8.4.2.4 Configuring Device Alarm

Set device alarm. When alarm input device sends an alarm signal to IVSS, an alarm is triggered.



- Make sure that IVSS is connected with alarm input device.
- IVSS supports 16-channel alarm input. Configure according to actual port of alarm input device. Take ALARM1 port connection for example.

Step 1 Click , or click  on the configuration interface, and then select **EVENT**.

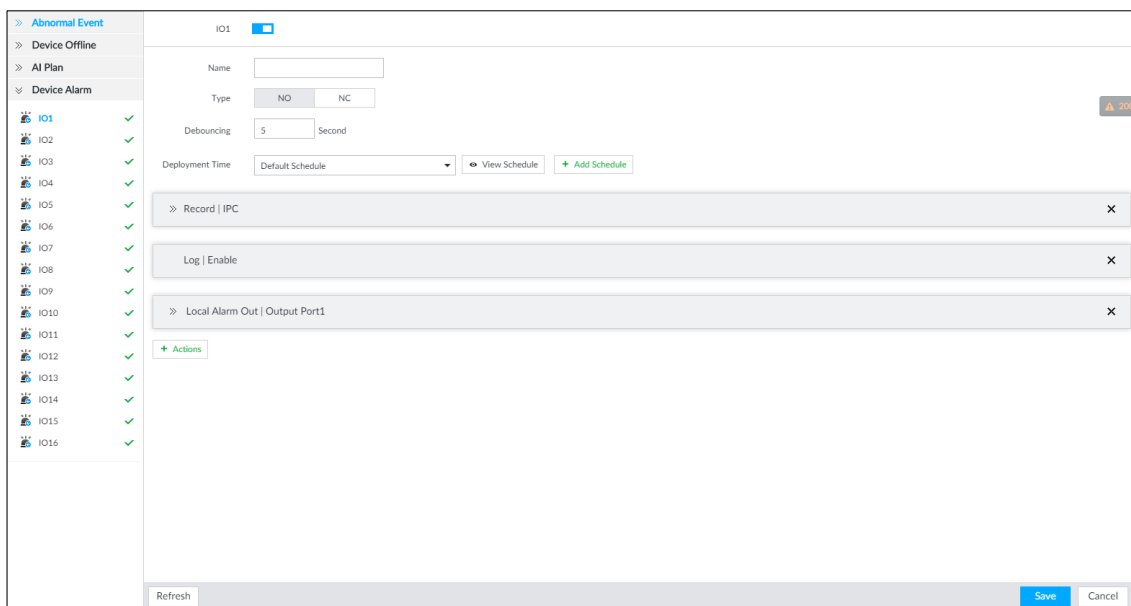
The **EVENT** interface is displayed.

Step 2 Select the root node in the device tree on the left.

Step 3 Select **Device Alarm > IO1**.

The **IO1** interface is displayed. See Figure 8-65.

Figure 8-65 IO1



Step 4 Click to enable local alarm.

Step 5 Set parameters. For details, see Table 8-20.

Table 8-20 Local alarm parameters description

Parameters	Description
Name	In the Alarm name box, enter a name for the alarm.
Type	Select alarm input device type. Both NO and NC are supported.
Debouncing	The system records only one event during this period.

Step 6 Click **Deployment Time** to select schedule from the drop-down list.

After setting deployment period, system triggers corresponding operations when there is a motion detection alarm in the specified period.

- Click **View Schedule** to view detailed schedule settings.
- If the schedule is not added or the added schedule does not meet actual needs, click **Add Schedule**. See "8.8.4 Schedule" for detailed information.

Step 7 Click **Actions** to set alarm actions. See "8.4.1 Alarm Actions" for detailed information.

Step 8 Click **Save**.

8.4.3 Remote Device

Set alarm actions of remote device, including video detection alarm, offline alarm and AI plan of remote device.



The parameters might be different depending on the model you purchased. The actual interface shall prevail.



8.4.3.1 Video Detect

Video detection function adopts the PC visual, image and graphical processing technology to analyze the video image and check there is considerable changes on the video. Once there

are considerable video changes (such as there is any moving object, or the video is blurred), system triggers corresponding alarm event.

8.4.3.1.1 Configuring Video Motion

After analyzing video, system can generate a video motion alarm when the detected moving target reaches the sensitivity you set here.

Step 1 Click , or click  on the configuration interface, and then select **EVENT**.

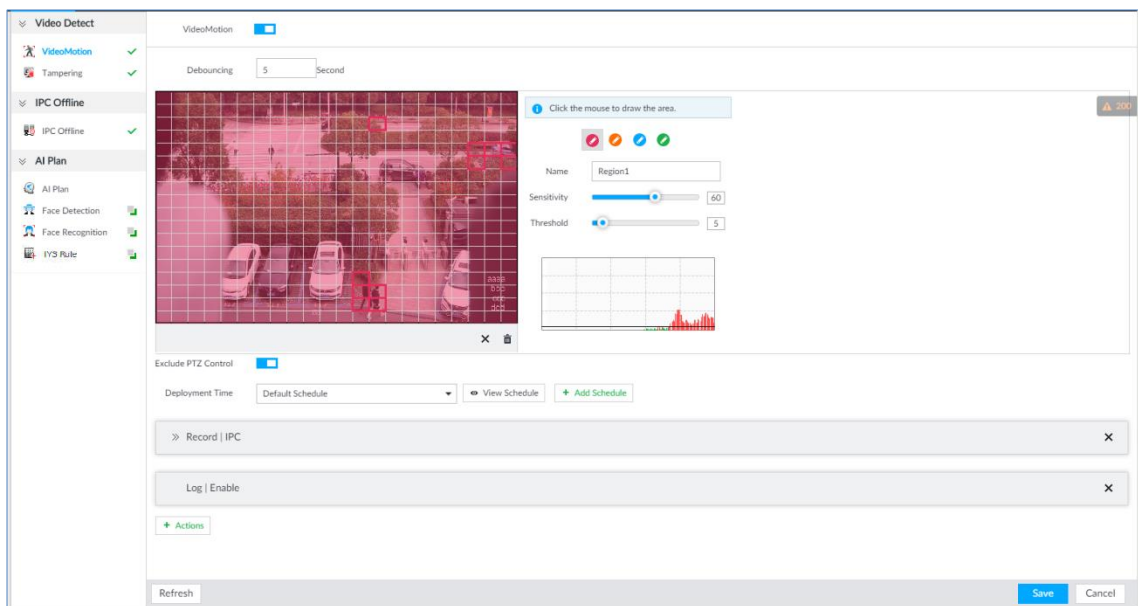
The **EVENT** interface is displayed.

Step 2 Select remote device in the device tree on the left.

Step 3 Select **Video Detect > Video Motion**.

The **Video Motion** interface is displayed. See Figure 8-66.


Figure 8-66 Video motion



Step 4 Click  to enable video motion detection.


Step 5 Set parameters. For details, see Table 8-21.

Table 8-21 Motion detect parameters description

Parameters	Description
Debouncing	System only records one alarm event during the debouncing period.
Exclude PTZ control	After enabling exclude PTZ control, system does not trigger an alarm when you are manually control the PTZ.  It is for PTZ camera only.

Step 6 Set motion detection region.

System supports maximum four detection zones. After setting, once there is an alarm from any of these four zones, the remote device trigger an alarm.

- 1) Click motion detection zone icon .
- 2) On the surveillance video, press and hold on the left button of mouse to select detection zone.





- Select the motion detect zone you have drawn. Click  to delete the zone.
 - Click  to clear the zone you have drawn.
- 3) Set parameters. For details, see Table 8-22.

Table 8-22 Description of zone parameters

Parameters	Description
Name	Set detection zone name to distinguish different zones.
Sensitivity	<p>Drag  to set sensitivity.</p> <p>The higher the sensitivity is, the easier it is to trigger an alarm. At the same time, the false alarm rate increases as well. Usually we recommend the default value.</p>
Threshold	<p>Drag  to adjust threshold.</p> <p>Once the detected percentage (the percentage of target to detection zone) is equivalent to or larger than the specified threshold, system triggers alarm. For example, the threshold is 10. Once the detected target occupies the 10% of the detection zone, system triggers an alarm.</p>

Step 7 Click **Deployment Time** to select schedule from the drop-down list.

After setting deployment period, system triggers corresponding operations when there is a motion detection alarm in the specified period.

- Click **View Schedule** to view detailed schedule settings.
- If the schedule is not added or the added schedule does not meet actual needs, click **Add Schedule**. See "8.8.4 Schedule" for detailed information.

Step 8 Click **Actions** to set alarm actions. See "8.4.1 Alarm Actions" for detailed information.

Step 9 Click **Save**.

8.4.3.1.2 Tampering

Once something tampers the surveillance video, and the output video is in one color, the system can generate an alarm.

Step 1 Click , or click  on the configuration interface, and then select **EVENT**.

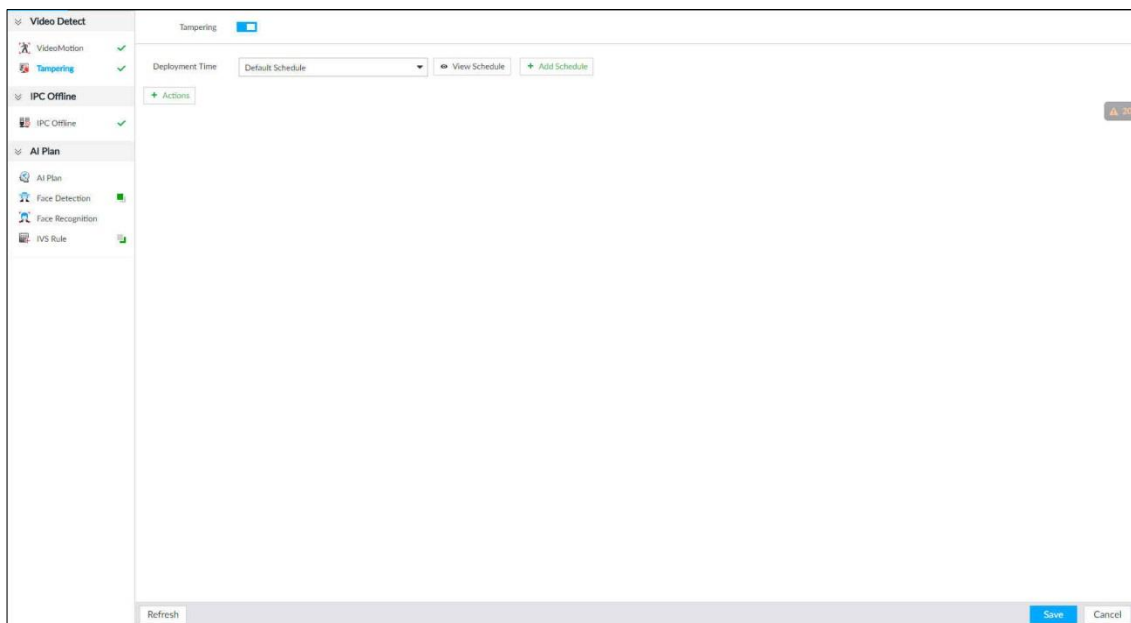
The **EVENT** interface is displayed.


Step 2 Select remote device in the device tree on the left.

Step 3 Select **Video Detect > Tampering**.

The **Tampering** interface is displayed. See Figure 8-67.

Figure 8-67 Tampering



Step 4 Click  to enable tampering alarm.

Step 5 Click **Deployment Time** to select schedule from the drop-down list.

After setting deployment period, system triggers corresponding operations when there is a motion detection alarm in the specified period.

- Click **View Schedule** to view detailed schedule settings.
- If the schedule is not added or the added schedule does not meet actual needs, click **Add Schedule**. See "8.8.4 Schedule" for detailed information.

Step 6 Click **Actions** to set alarm actions. See "8.4.1 Alarm Actions" for detailed information.

Step 7 Click **Save**.

8.4.3.2 Offline Alarm

When the remote device and the IVSS are disconnected, system can trigger an alarm.

Step 1 Click , or click  on the configuration interface, and then select **EVENT**.

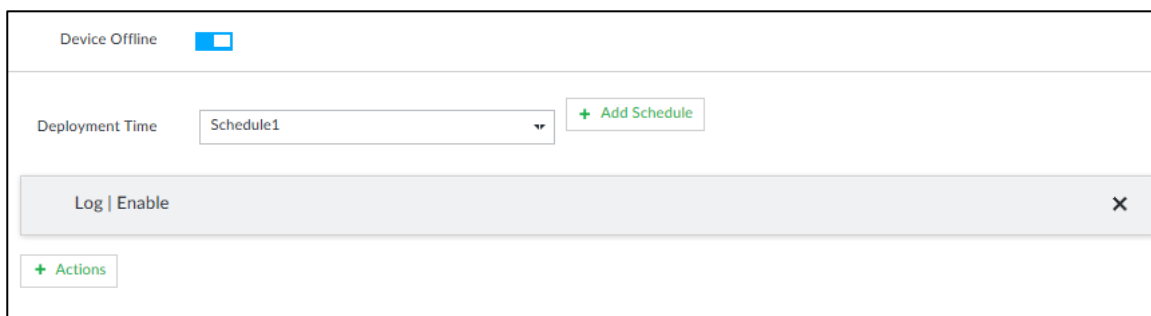
The **EVENT** interface is displayed.

Step 2 Select a remote device in the device tree on the left.

Step 3 Select **Device Offline > Device Offline**.

The **Device Offline** interface is displayed. See Figure 8-68.

Figure 8-68 IPC offline



Step 4 Click to enable offline alarm.



The device offline alarm is enabled by default. You can skip this step.

Step 5 Click **Deployment Time** to select schedule from the drop-down list.

After setting deployment period, system triggers corresponding operations when there is a device offline alarm in the specified period.

- Click **View Schedule** to view detailed schedule settings.
- If the schedule is not added or the added schedule does not meet actual needs, click **Add Schedule**. See "8.8.4 Schedule" for detailed information.

Step 6 Click **Actions** to set alarm actions. See "8.4.1 Alarm Actions" for detailed information.

Step 7 Click **Save**.

8.4.3.3 IPC External Alarm

Set IPC alarm input event, so that when there is an alarm input to the IPC, IPC uploads the alarm to the Device. If the camera has multiple IO channels, you can set the alarm input event for each of them as you might need.

Step 1 Click , or click  on the configuration interface, and then select **EVENT**.

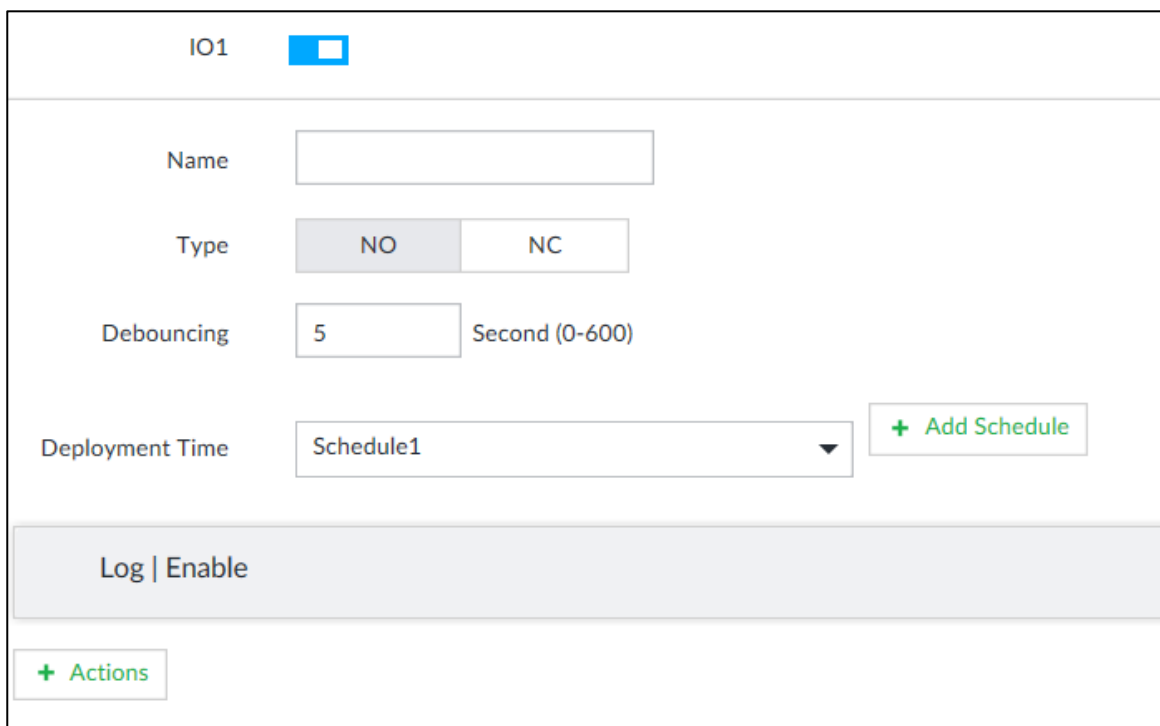
The **EVENT** interface is displayed.

Step 2 Select a remote device in the device tree on the left.

Step 3 Select **External Alarm > IO1**.

The **IO1** interface is displayed. See Figure 8-69.

Figure 8-69 IO1



IO1

Name

Type NO NC

Debouncing Second (0-600)

Deployment Time

Log | Enable

Step 4 Click to enable the alarm.

Step 5 Set parameters. For details, see Table 8-20.

Table 8-23 Local alarm parameters description

Parameters	Description
Name	In the Alarm name box, enter a name for the alarm.
Type	Select alarm input device type. Both NO and NC are supported.
Debouncing	The system records only one event during this period.

Step 6 Click **Deployment Time** to select schedule from the drop-down list.

After setting deployment period, system triggers corresponding operations when there is a motion detection alarm in the specified period.

- Click **View Schedule** to view detailed schedule settings.
- If the schedule is not added or the added schedule does not meet actual needs, click **Add Schedule**. See "8.8.4 Schedule" for detailed information.

Step 7 Click **Actions** to set alarm actions. See "8.4.1 Alarm Actions" for detailed information.

Step 8 Click **Save**.

8.4.3.4 Thermal Alarm



- Alarm types vary depending on the models of thermal cameras. The actual interface shall prevail.
- Make sure that configurations of thermal detections such as fire detection and temperature detection have been done on the thermal camera.

Support the following thermal camera alarms. See Table 8-24.

Table 8-24 Thermal alarms

Function	Description
Fire alarm	When the thermal camera detects a fire, the alarm signal is transmitted to the IVSS device, which performs an alarm linkage action.
Temperature alarm	When the thermal camera detects that the temperature is above or below the threshold value, the alarm signal is transmitted to the IVSS device, which performs an alarm linkage action.
Temperature difference alarm	When the thermal camera detects a temperature difference greater than the set value, the alarm signal is transmitted to the IVSS device, and the IVSS device will perform an alarm linkage action.
Hot spot alarm	When the maximum temperature detected by the thermal camera is higher than the set value, the alarm signal is transmitted to the IVSS device, and the IVSS device will perform an alarm linkage action.
Cold spot alarm	When the lowest temperature detected by the thermal camera is below the set value, the alarm signal is transmitted to the IVSS device, and the IVSS device will perform an alarm linkage action.

Take the procedure of configuring fire alarm as an example. The procedures are similar, and the actual interface shall prevail.

Step 1 Click , or click  on the configuration interface, and then select **EVENT**.

The **EVENT** interface is displayed.

Step 2 Select the root node in the device tree on the left.

Step 3 Select **Thermal Alarm > Fire Alarm**.

The **Fire Alarm** interface is displayed.

Step 4 Click **Deployment Time** to select schedule from the drop-down list.



After setting deployment period, system triggers corresponding operations when there is a motion detection alarm in the specified period.

- Click **View Schedule** to view detailed schedule settings.
- If the schedule is not added or the added schedule does not meet actual needs, click **Add Schedule**. See "8.8.4 Schedule" for detailed information.

Step 5 Click **Actions** to set alarm actions. See "8.4.1 Alarm Actions" for detailed information.

Step 6 Click **Save**.

8.5 Storage Management

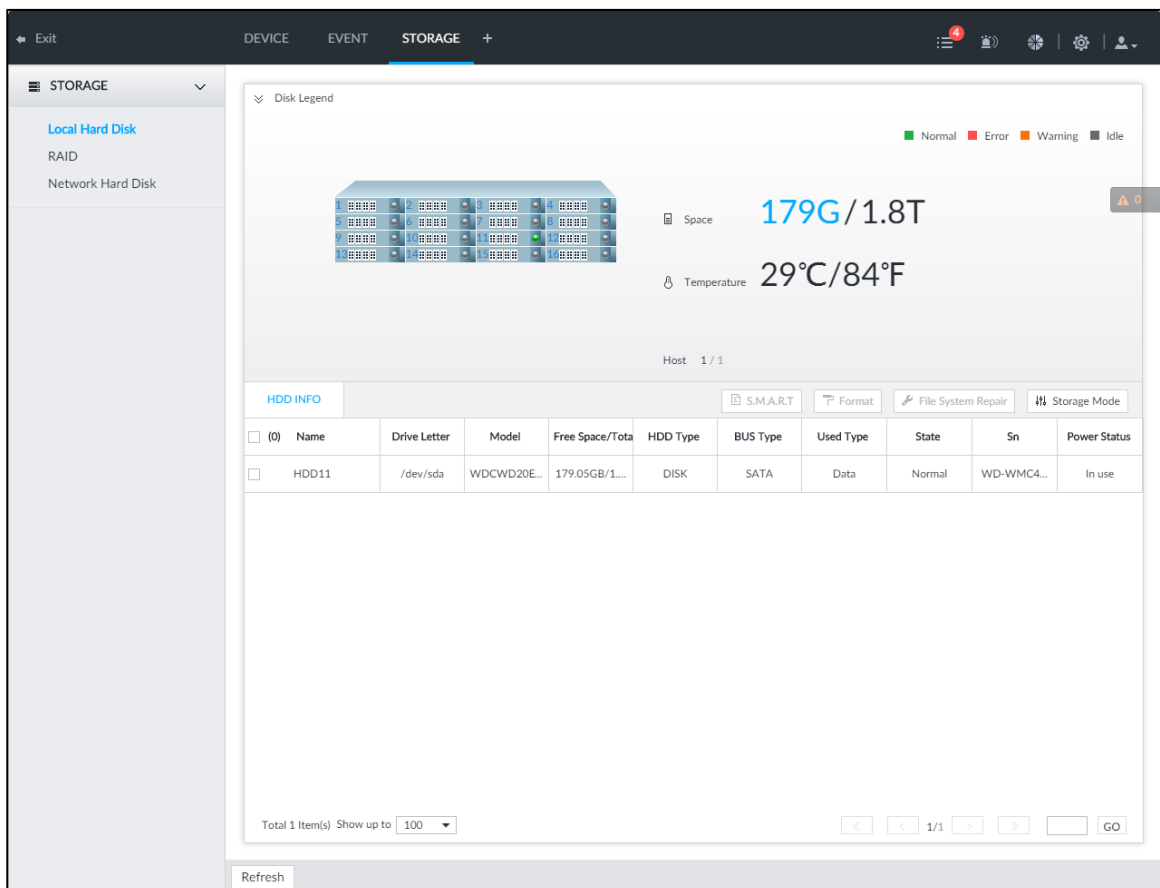
Click  or click  on the configuration interface, select **STORAGE**. The **STORAGE** interface is displayed. See Figure 8-70. Manage storage resources (such as recording file) and space, so you can use and improve utilization ratio of storage space.



The system supports pre-check and routine inspection function, and displays health status on the **STORAGE** interface, so you can obtain real-time status of device and avoid data loss.

- **Pre-check:** During device operation, the system automatically detects disc status in case of change (reboot, insert and pull the disc).
- **Routine inspection:** the system carries out routine inspection of the disc continuously. During device operation, the disc might go wrong due to service life, environment and other factors. Find out any problems during routine inspection.

Figure 8-70 Storage management








The screenshot displays the Storage Management interface. At the top, there are navigation tabs for DEVICE, EVENT, and STORAGE. The STORAGE tab is active. On the left, there is a sidebar with options: Local Hard Disk, RAID, and Network Hard Disk. The main area shows a 'Disk Legend' with a color-coded status bar (Normal, Error, Warning, Idle). Below this, there is a visual representation of a storage array and key metrics: Space usage (179G / 1.8T) and Temperature (29°C / 84°F). A table titled 'HDD INFO' provides details for the installed hard drive.

(0)	Name	Drive Letter	Model	Free Space/Tota	HDD Type	BUS Type	Used Type	State	Sn	Power Status
<input type="checkbox"/>	HDD11	/dev/sda	WDCWD20E...	179.05GB/1...	DISK	SATA	Data	Normal	WD-WMC4...	In use

8.5.1 Local Hard Disk

The local hard disk refers to the HDD installed on the system. On this interface, you can view HDD space (free space/total space), temperature (centigrade/Fahrenheit), HDD information and so on.

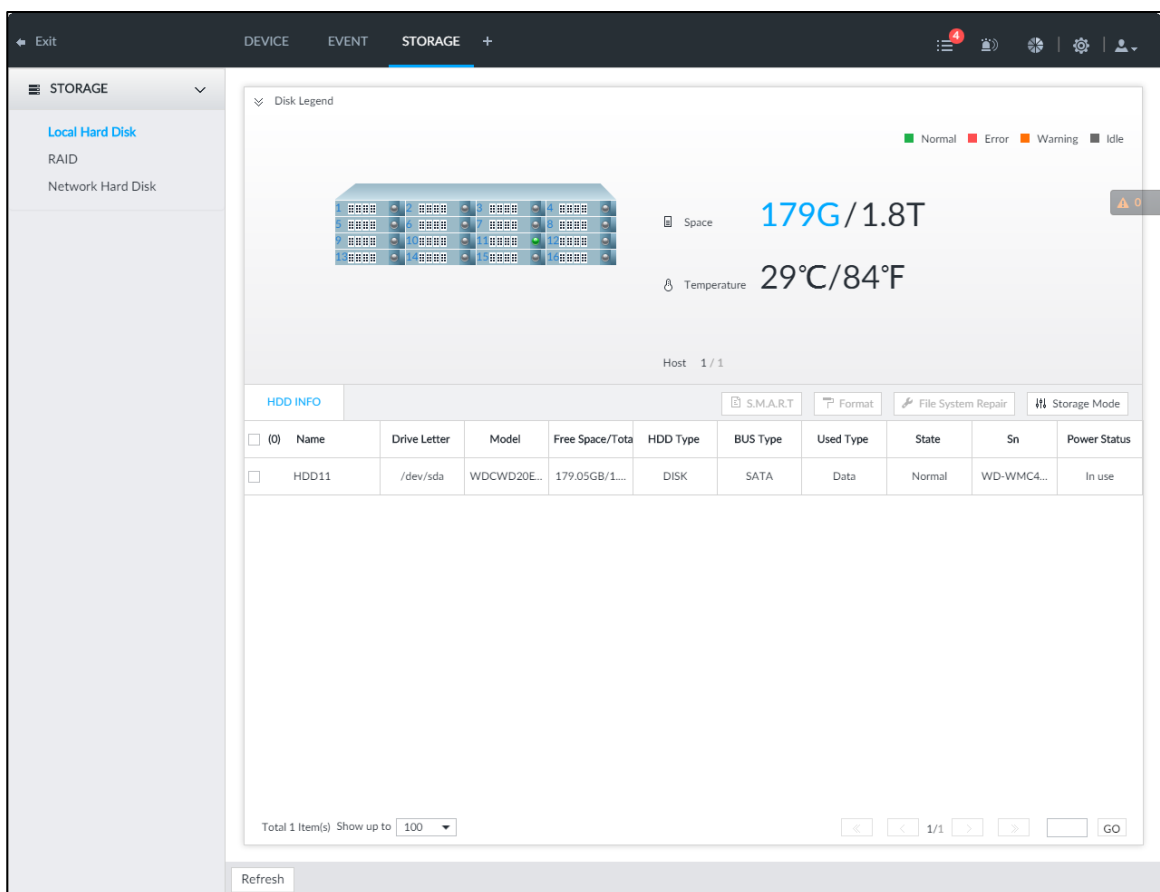
Click , or click  on the configuration interface, and then select **STORAGE > Local Hard Disk**. The **Local Hard Disk** interface is displayed. See Figure 8-71. There is a corresponding icon near the HDD name after you create the RAID and hot spare HDD.

-  : RAID HDD.
-  : Global hot spare HDD.
-  : Invalid HDD of RAID group.



Slight difference might be found on the user interface. The actual interface shall prevail.

Figure 8-71 HDD



The screenshot displays the 'Local Hard Disk' configuration page. At the top, there's a navigation bar with 'Exit', 'DEVICE', 'EVENT', and 'STORAGE +'. The left sidebar shows 'STORAGE' with sub-options: 'Local Hard Disk', 'RAID', and 'Network Hard Disk'. The main content area features a 'Disk Legend' with a color key: Normal (green), Error (red), Warning (orange), and Idle (grey). Below this is a visual representation of a server rack with 12 drives, and a summary of the selected drive: Space 179G/1.8T and Temperature 29°C/84°F. A 'Host 1 / 1' indicator is present. The 'HDD INFO' section includes a table with columns: Name, Drive Letter, Model, Free Space/Tota, HDD Type, BUS Type, Used Type, State, Sn, and Power Status. The table contains one entry for 'HDD11' with drive letter '/dev/sda', model 'WDCWD20E...', and a power status of 'In use'. At the bottom, there's a 'Refresh' button and a pagination control showing 'Total 1 Item(s) Show up to 100'.

(0)	Name	Drive Letter	Model	Free Space/Tota	HDD Type	BUS Type	Used Type	State	Sn	Power Status
<input type="checkbox"/>	HDD11	/dev/sda	WDCWD20E...	179.05GB/1...	DISK	SATA	Data	Normal	WD-WMC4...	In use

8.5.1.1 Viewing S.M.A.R.T

S.M.A.R.T is so called Self-Monitoring Analysis and Reporting Technology. It is a technical standard to check HDD drive status and report potential problems. System monitors the HDD running status and compares with the specified safety value. Once the monitor status is

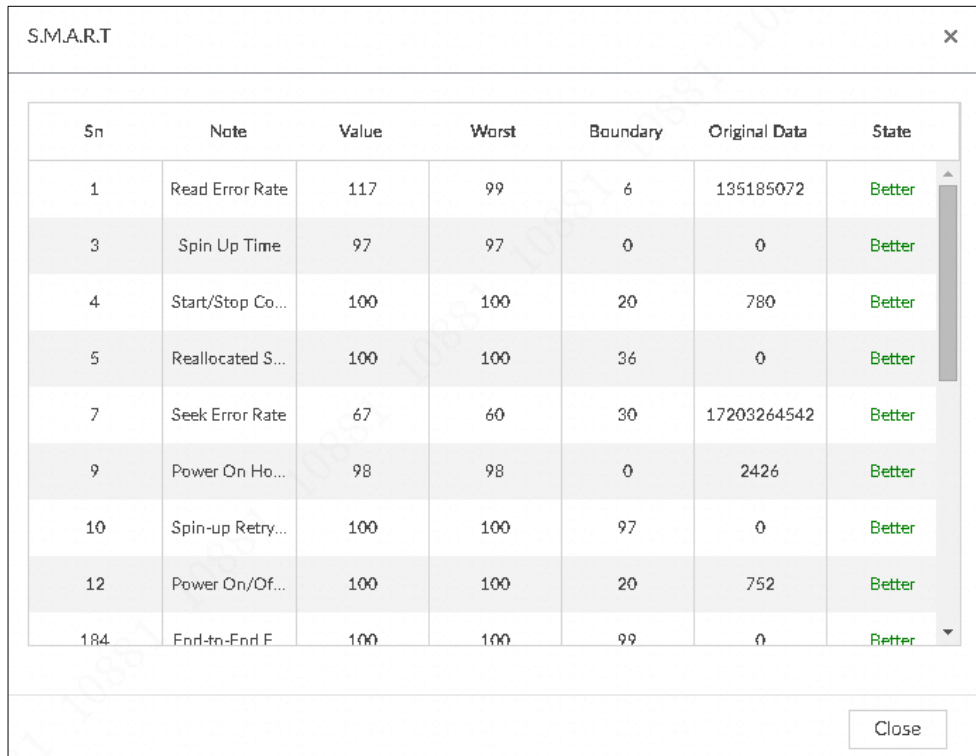
higher than the specified value, system displays alarm information to guarantee HDD data security.



Check one HDD to view S.M.A.R.T information at one time.

On the **Local Hard Disk** interface, select a HDD, and then click **S.M.A.R.T**. The **S.M.A.R.T** interface is displayed. See Figure 8-72. Check whether the HDD status is **OK** or not. If there is any problem, fix it in time.

Figure 8-72 S.M.A.R.T



Sn	Note	Value	Worst	Boundary	Original Data	State
1	Read Error Rate	117	99	6	135185072	Better
3	Spin Up Time	97	97	0	0	Better
4	Start/Stop Co...	100	100	20	780	Better
5	Reallocated S...	100	100	36	0	Better
7	Seek Error Rate	67	60	30	17203264542	Better
9	Power On Ho...	98	98	0	2426	Better
10	Spin-up Retry...	100	100	97	0	Better
12	Power On/Of...	100	100	20	752	Better
184	End-to-End F...	100	100	99	0	Better

8.5.1.2 Format



- Formatting HDD will clear all data on the HDD. Be careful!
- Hot spare HDD cannot be formatted.

Enter the **Local Hard Disk** interface, select one or more HDD(s), and click **Format**. It is to format the selected HDD.



8.5.1.3 File System Repair

Once you cannot mount the HDD or you cannot properly use the HDD, you can try to use the **File System Repair** function to fix the problem.

Enter the **Local Hard Disk** interface, select one or more HDD(s) you cannot mount, and click **File System Repair**, you can repair the selected file system of the corresponding HDD(s). The repaired HDD can work properly or to be mounted.

8.5.1.4 Setting Storage Strategy

Set storage strategy when HDD space is full.

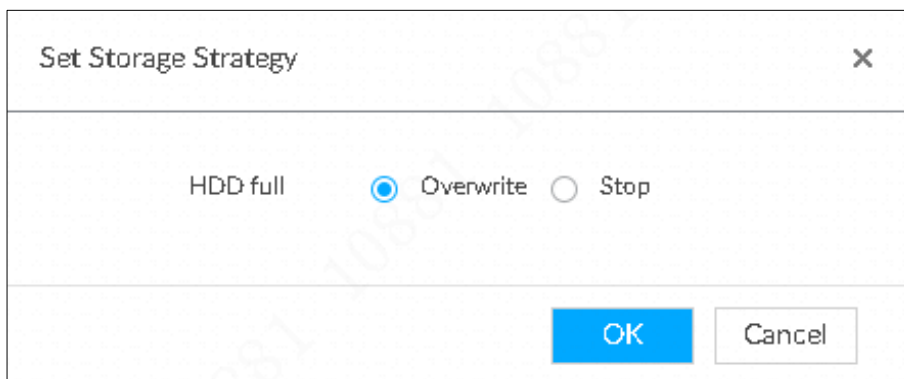
Step 1 Click , or click  on the configuration interface, and then select **STORAGE > Local Hard Disk**.

The **Local Hard Disk** interface is displayed.

Step 2 Click **Storage Strategy**.

The **Set Storage Strategy** interface is displayed. See Figure 8-73.

Figure 8-73 Set storage strategy



Step 3 Set storage strategy.

- **Overwrite:** When HDD free space is less than 150G or 4% of the total space (the larger of the two values prevails), system continues to record and begins overwriting the oldest record file.
- **Stop:** When HDD free space is less than 150G or 4% of the total space (the larger of the two values prevails), system stops recording. Stop recording will trigger an alarm. For details, see "8.4.2.1 Abnormal Event."

Step 4 Click **OK** to save the configuration.

8.5.1.5 Viewing RAID Group



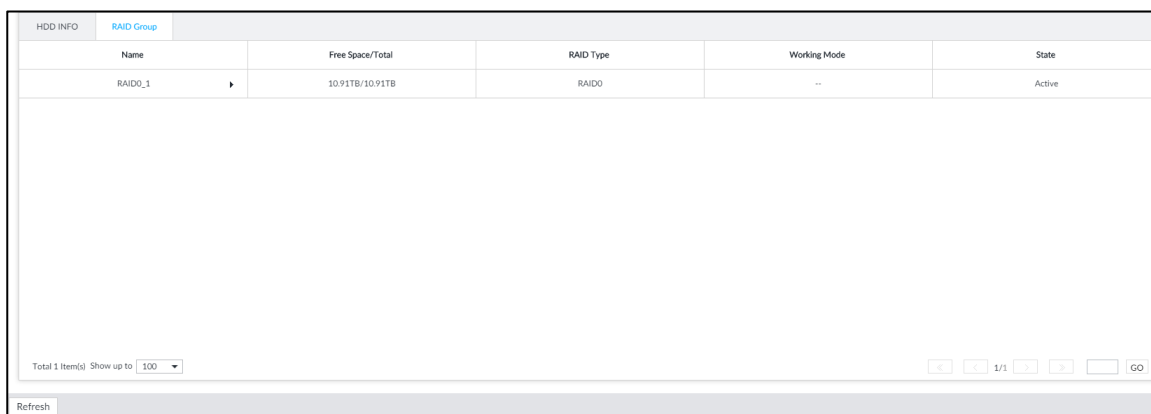


Click , or click  on the configuration interface, and then select **STORAGE > Local Hard Disk > RAID Group**. The **RAID Group** interface is displayed. You can view free space, RAID type, working mode and status of RAID group.

Figure 8-74 RAID group



Name	Free Space/Total	RAID Type	Working Mode	State
RAID0_1	10.91TB/10.91TB	RAID0	--	Active

- Click  next to the RAID name to display the RAID member list, and then you can view RAID member details.
- Point to the **Status** column, and then click  to display the **Details** interface to view RAID group details.

8.5.2 RAID

RAID (Redundant Array of Independent Disks) is a data storage virtualization technology that combines multiple physical HDD components into a single logical unit for the purposes of data redundancy, performance improvement, or both.



- The Device supports RAID 0, RAID 1, RAID5, RAID6, RAID10, RAID 50 and RAID60. See "Appendix 2 RAID" for detailed information.
- You are recommended to use enterprise HDD when you are creating RAID, and use surveillance HDD for single-HDD mode.

8.5.2.1 Creating RAID

RAID has different levels such as RAID5, RAID6 and so on. Different RAID levels have different data protection, data availability and performance levels. Create RAID according to your actual requirements.



Creating RAID operation is going to clear all data on these HDD. Be careful!

Strategy of automatic creation

For automatic creation of RAID, the system adopts different creation strategies according to disc quantity. For details, see Table 8-25.





In the following table, among the numbers in the creation strategy, the number without () represents the disk number of the RAID group. The number with () represents the number of hot spare disks. For example, for 24 HDD, the creation strategy is 7+7+9+(1). It means three RAID5 and one hot spare, and each RAID5 respectively contains 7 disks, 7 disks and 9 disks.

Table 8-25 Shortcut menu to create RAID

HDD No.	Creation Strategy	HDD No.	Creation Strategy
3	Not recommended	14	6+7+(1)
4	Not recommended	15	7+7+(1)
5	5	16	5+5+5+(1)
6	5+(1)	17	5+5+6+(1)
7	6+(1)	18	5+6+6+(1)
8	7+(1)	19	6+6+6+(1)
9	8+(1)	20	6+6+7+(1)
10	9+(1)	21	6+7+7+(1)

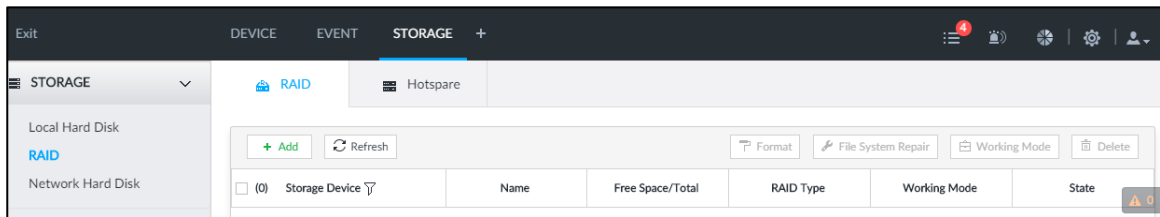
HDD No.	Creation Strategy	HDD No.	Creation Strategy
11	5+5+(1)	22	7+7+7+(1)
12	5+6+(1)	23	7+7+8+(1)
13	6+6+(1)	24	7+7+9+(1)

Create RAID

Step 1 Click , or click  on the configuration interface, and then select **STORAGE > RAID > RAID**.

The **RAID** interface is displayed. See Figure 8-75.

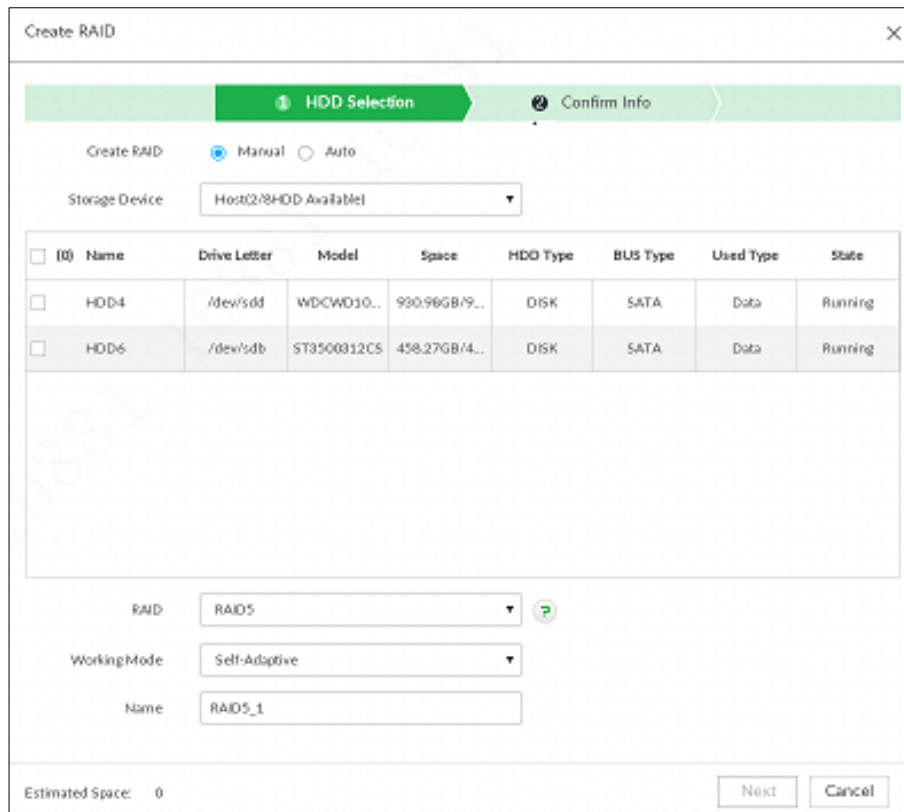
Figure 8-75 RAID (1)



Step 2 Click **Add**.

The **Create RAID** interface is displayed. See Figure 8-76.

Figure 8-76 Create RAID (1)




Step 3 Set RAID parameters.

Select RAID creation type according to actual situation. It includes **Manual RAID** and **Auto RAID**.

- Manual RAID: System creates a specified RAID type according to the selected HDD amount.
 - 1) Select Manual RAID.

- 2) Select HDD you want to use.
- 3) Set parameters. For details, see Table 8-26.

Table 8-26 Manual creation parameters description

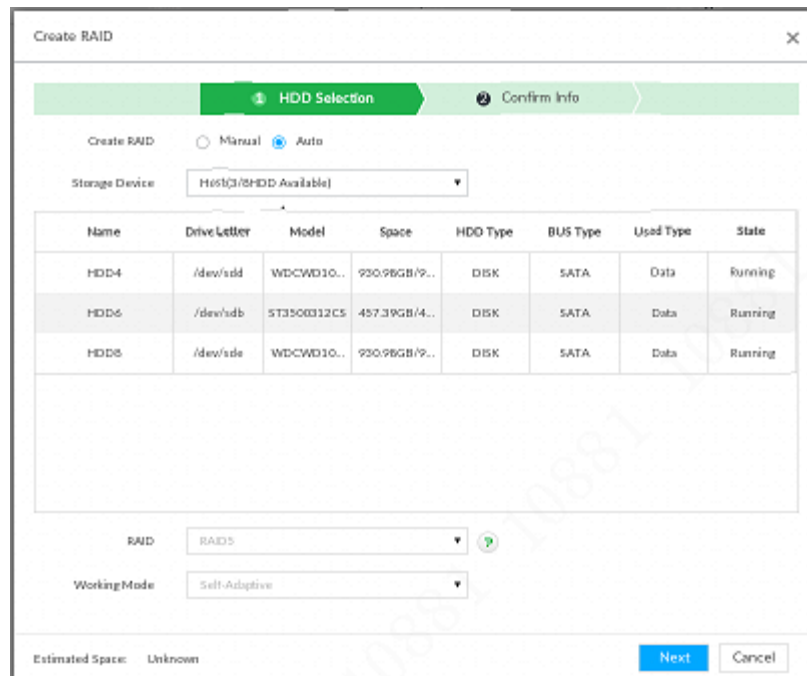
Parameters	Description
Storage Device	It is to select storage device of the HDD and select the HDD you want to add to the RAID.  Different RAID types need different HDD amounts, and the actual situation shall prevail.
RAID	Select a RAID type you want to create.
Working mode	Set RAID resources allocation mode. The default setup is self-adaptive. <ul style="list-style-type: none"> ● Self-adaptive means the system can automatically adjust RAID synchronization speed according to current business load. When there is no external business, the synchronization speed is at high speed. When there is external business, the synchronization speed is at low speed. ● Sync first: Allocate resources to RAID synchronization first. ● Business first: Allocate resources to business first. ● Load-Balance: Allocate resources to business and RAID synchronization equally.
Name	Set RAID name.

- Auto: System creates RAID5 according to the HDD amount.

- 1) Select **Auto**.

The **Auto** interface is displayed. See Figure 8-77.

Figure 8-77 Create RAID (2)



- 2) Set parameters. For details, see Table 8-27.

Table 8-27 Auto parameters description

Parameters	Description
Storage Device	Select storage device of the HDD.

Parameters	Description
Working mode	<p>Set RAID resources allocation mode. The default setup is self-adaptive.</p> <ul style="list-style-type: none"> Self-adaptive means the system can automatically adjust RAID synchronization speed according to current business load. When there is no external business, the synchronization speed is at high speed. When there is external business, the synchronization speed is at low speed. Sync first: Allocate resources to RAID synchronization first. Business first: Allocate resources to business first. Load-Balance: Allocate resources to business and RAID synchronization equally.

Step 4 Click **Next**.

The **Confirm Info** interface is displayed. See Figure 8-78 or Figure 8-79.

Figure 8-78 Confirm info (manual)

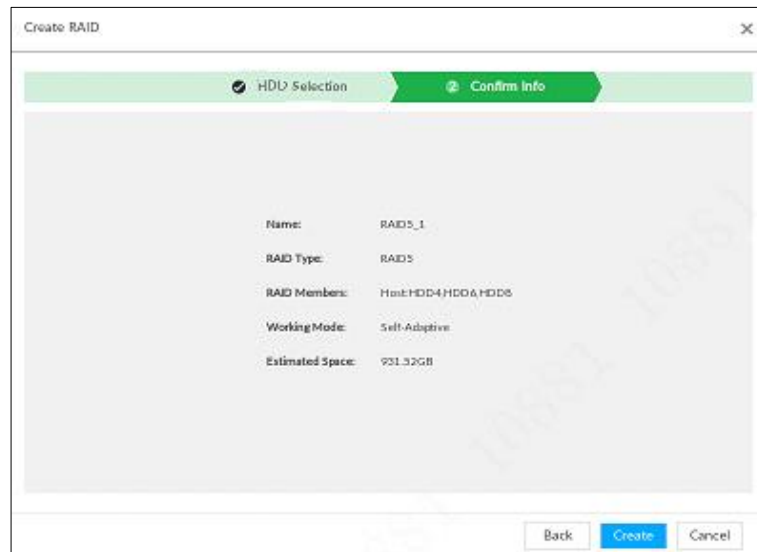
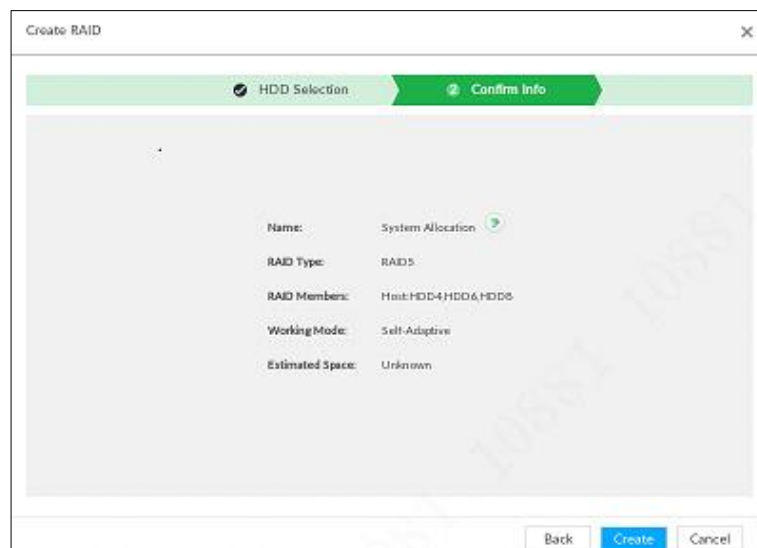


Figure 8-79 Confirm info (Auto)



Step 5 Confirm info.

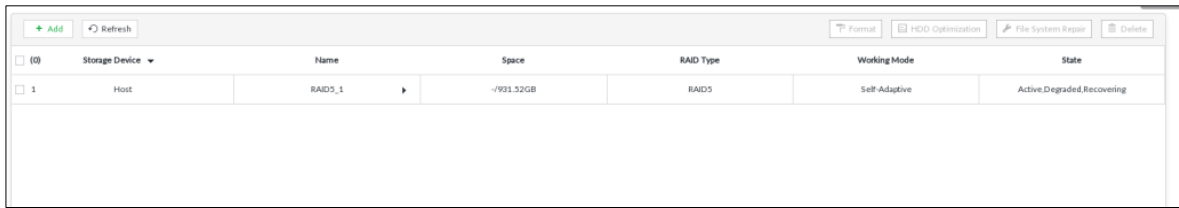


If the entered information is wrong, click **Back** to set RAID parameters again.

Step 6 Click **Create**.

System begins to create RAID. It displays RAID information after creation. See Figure 8-80.

Figure 8-80 RAID (2)



Operation

After creating RAID, view RAID disk status and details, clear up RAID, and repair file system. For details, see Table 8-28.

Table 8-28 RAID operation





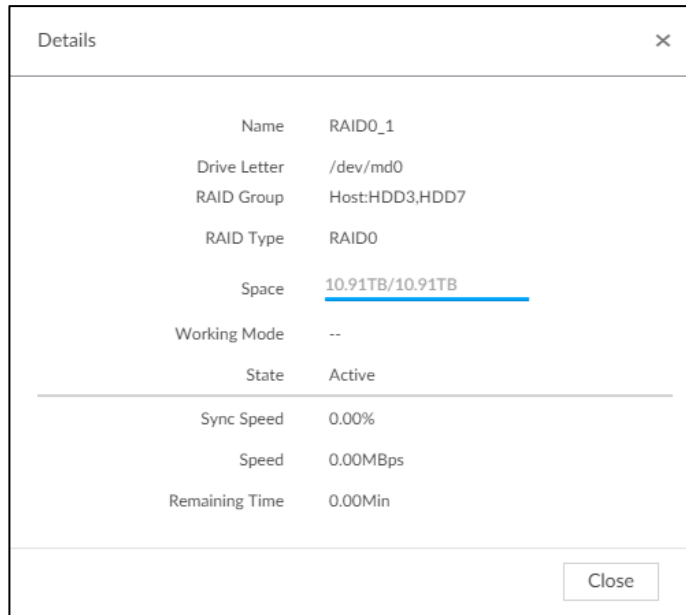


Name	Operation
View RAID HDD status	Click  at the right side of the RAID name to open the RAID HDD list. It is to view RAID HDD space, status and so on.
View RAID details	Click  . It displays detailed information. See Figure 8-81. It is to view RAID detailed information.
File System Repair	Once you cannot mount the RAID or you cannot properly use the RAID, you can try to use repair file system function to fix. Enter RAID interface, select one or more RAID(s) you cannot mount, click File System Repair , you can repair the selected file system of the corresponding RAID(s). The repaired RAID can work properly or to be mounted.
Modify Working Mode	Select one or more RAID(s), and then click Working Mode to modify the working mode.
Format RAID	 Formatting RAID is to clear all data on the RAID and cancel the RAID group. Please be careful. Enter RAID interface, select one and more RAID groups. Click Format to format the selected RAID.
Delete RAID	 Deleting RAID is to clear all data on the RAID and cancel the RAID group. Please be careful. Enter RAID interface, select one and more RAID groups. Click Delete to delete the selected RAID.

Figure 8-81 RAID details



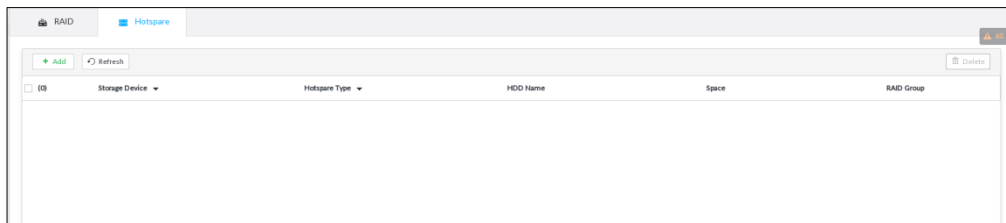
8.5.2.2 Creating Hot Spare HDD

When a HDD of the RAID group is malfunctioning or has a problem, the hot spare HDD can replace the malfunctioning HDD. There is no risk of data loss and it can guarantee storage system reliability.

Step 1 Click , or click  on the configuration interface, and then select **STORAGE > RAID > Hot spare**.

The **Hot spare** interface is displayed. See Figure 8-82.

Figure 8-82 Hot spare (1)



Step 2 Click **Add**.

The **Add** interface is displayed. See Figure 8-83 or Figure 8-84.

Figure 8-83 Global hot spare

The screenshot shows the 'Add Hotspare' dialog box with the 'HDD Selection' step active. The 'Creation Type' is set to 'Global Hotspare'. The 'Storage Device' dropdown shows 'Host3/8HDD Available'. A table lists three available HDDs: HDD4, HDD6, and HDD8. Each row includes a checkbox, name, drive letter, model, space, HDD type, bus type, used type, and state.

<input type="checkbox"/>	(0) Name	Drive Letter	Model	Space	HDD Type	BUS Type	Used Type	State
<input type="checkbox"/>	HDD4	/dev/sdd	WDCWD10...	990.98GB/9...	DISK	SATA	Data	Running
<input type="checkbox"/>	HDD6	/dev/sdb	ST3500312CS	465.51GB/4...	DISK	SATA	Data	Running
<input type="checkbox"/>	HDD8	/dev/sde	WDCWD10...	990.98GB/9...	DISK	SATA	Data	Running

Figure 8-84 Private hot spare

The screenshot shows the 'Add Hotspare' dialog box with the 'HDD Selection' step active. The 'Creation Type' is set to 'Private Hotspare'. An 'Add' dropdown menu is visible. The table below lists the same three HDDs as in Figure 8-83.

<input type="checkbox"/>	(0) Name	Drive Letter	Model	Space	HDD Type	BUS Type	Used Type	State
<input type="checkbox"/>	HDD4	/dev/sdd	WDCWD10...	990.98GB/9...	DISK	SATA	Data	Running
<input type="checkbox"/>	HDD6	/dev/sdb	ST3500312CS	465.51GB/4...	DISK	SATA	Data	Running
<input type="checkbox"/>	HDD8	/dev/sde	WDCWD10...	990.98GB/9...	DISK	SATA	Data	Running

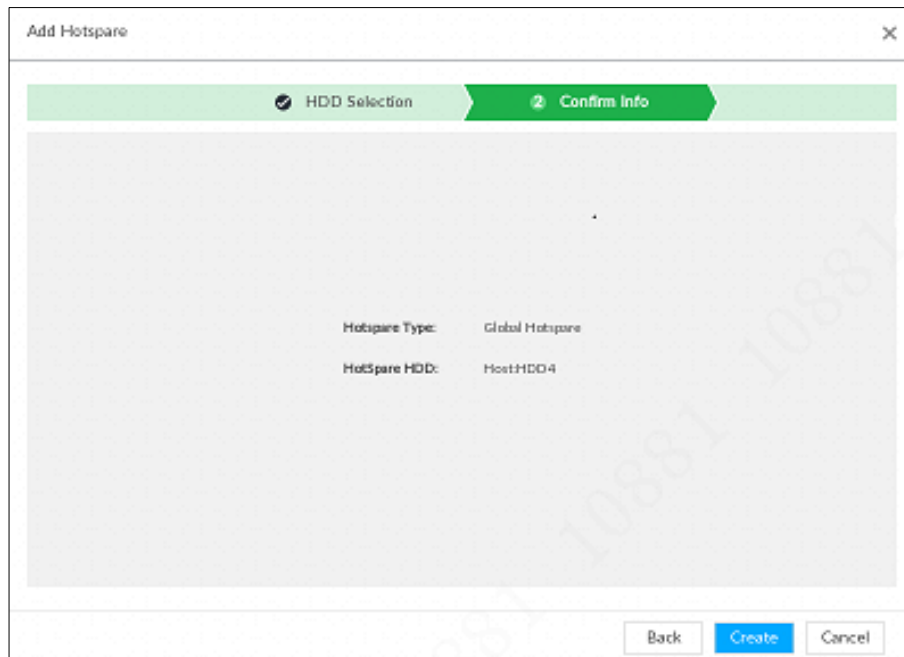
Step 3 Select hot spare creation type.

- Global hot spare: It is to create hot spare for all RAID. It is not a hot spare HDD for a specified RAID group.
- Private hot spare: Select **Private Hot spare** and **Add** it to a RAID group. The private hot spare HDD is for a specified RAID group.

Step 4 Select one or more HDD(s) and then click **Next**.

The **Confirm Info** interface is displayed. See Figure 8-85.

Figure 8-85 Confirm info



Step 5 Confirm info.

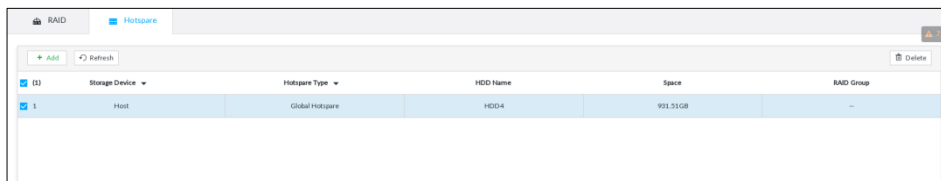


Click **Back** to select hot spare HDD(s) again if you want to change settings.

Step 6 Click **Create** to save settings.

System displays the added hot spare HDD information. See Figure 8-86.

Figure 8-86 Hot spare (2)





Select a hot spare HDD and then click **Delete** to delete hot spare HDD.

8.5.3 Network Hard Disk

Network hard disk is a network-based online storage service that stores device information in the network hard disk through the iSCSI protocol.

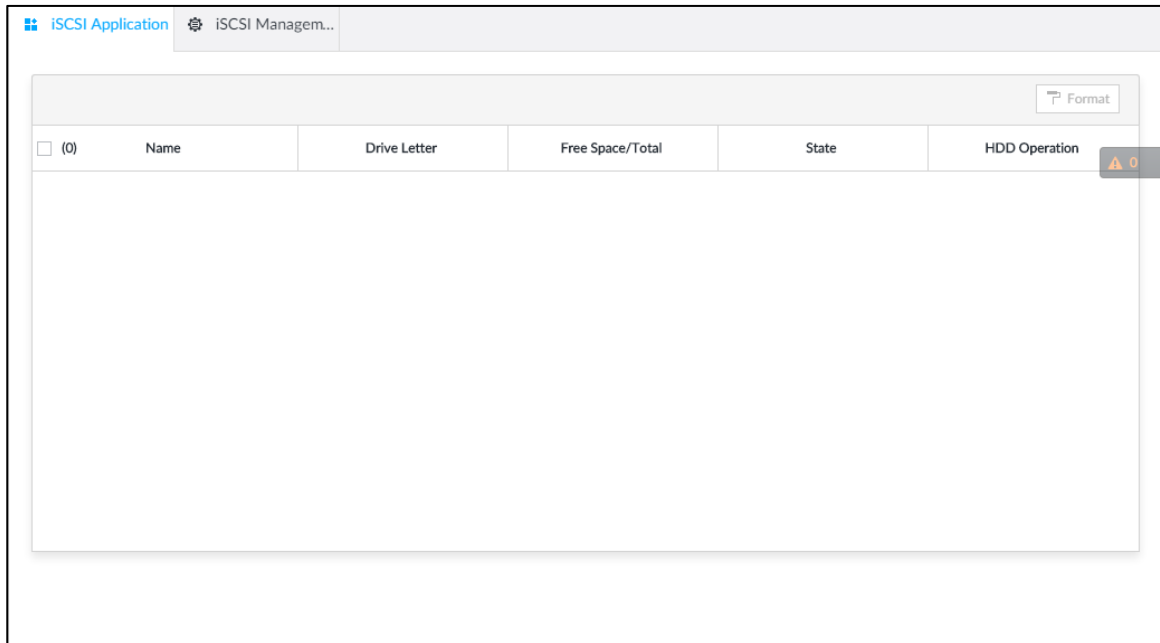
8.5.3.1 iSCSI Application

View network hard disk usage, including remaining capacity, and hard disk status.

Click , or click  on the configuration interface, and then select **STORAGE > Network Hard Disk > iSCSI Application**.

The **iSCSI Application** interface is displayed. See Figure 8-87.

Figure 8-87 iSCSI application





- Select a network hard disk, and then click **Format** to format the disk. Formatting your hard disk will erase all data from your hard disk, so do it carefully.
- Click the **HDD Operation** column, and then you can select an HDD operation permission type.
 - ◇ Read/Write: One can read, edit, add, and delete data of this disk.
 - ◇ Read Only: One can only read data of this disk.

8.5.3.2 iSCSI Management

Set up the network disk through iSCSI and map the network disk to the device so that the device can use the network disk for storage.

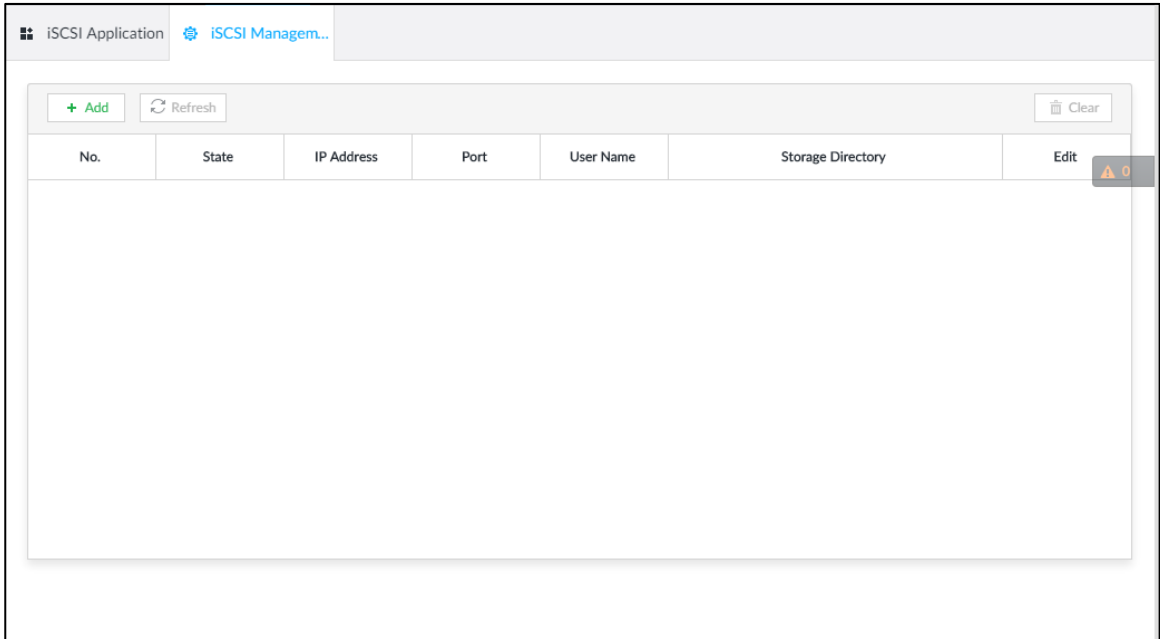


- iSCSI is a networked storage technology that runs SCSI protocols on the IP network.
- The network disk mapped to the device cannot be used to create a RAID.
- Make sure that service has been enabled on the iSCSI server and the server has provided the shared file directory.

Step 1 Click , or click  on the configuration interface, and then select **STORAGE > Network Hard Disk > iSCSI Management**.

The **iSCSI Management** interface is displayed. See Figure 8-88.

Figure 8-88 Network hard disk



Step 2 Click **+**.




The **Add** interface is displayed. See Figure 8-89.

Figure 8-89 Add iSCSI

Step 3 Set parameters. See Table 8-29.

Table 8-29 Network hard disk parameters


Parameters	Description
Server IP	Enter iSCSI server IP address.
Port	Enter iSCSI server port number. It is 3260 by default.

Parameters	Description
Anonymous	<p>If iSCSI server has no permission limitation, you can select anonymous login.</p> <ul style="list-style-type: none">  indicates that anonymous login is enabled and there is no need to set username and password.  indicates that anonymous login is disabled.
Username	If access permission has been limited when creating the shared file directory on the iSCSI server, you need to enter username and password.
Password	
Storage Directory	<p>Click Search Directory to select the storage directory.</p>  <p>The storage directory is generated when the shared file directory is being created on the iSCSI server. Each directory is an iSCSI disk.</p>



Step 4 Click **OK**.

The added network disk is displayed.



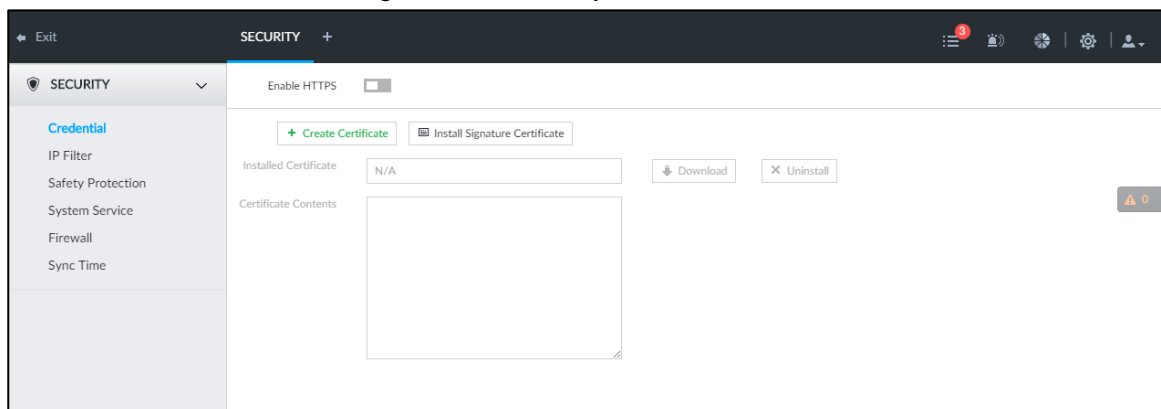
- Click  to delete a disk; click **Refresh** to refresh the disk list.
- On the Disk Group interface, you can configure network disk groups. For details, see "8.10.1.1 Setting Disk Group."

8.6 Security Strategy

Click  or click  on the configuration interface, select **SECURITY**. The **SECURITY** interface is displayed. See Figure 8-90.

Set security strategy to guarantee device network and data safety. It includes HTTPS, set host IP access rights, enable network security protection.

Figure 8-90 Security center



8.6.1 HTTPS

HTTPS can use the reliable and stable technological means to guarantee user information and device security and communication data security. After installing the certificate, you can use the HTTPS on the PC to access the device.



- HTTPS function is for web interface and PCAPP only. The actual interface shall prevail.
- You are recommended to enable HTTPS service. Otherwise, you might risk data leakage.

8.6.1.1 Installing Certificate

There are two ways to install the certificate.



- Manually create a certificate and then install.
- Upload a signature certificate and then install.

8.6.1.1.1 Installing the Created Certificate

Install the created certificate manually. It includes creating the certificate on the device, downloading and installing the certificate on the PC.

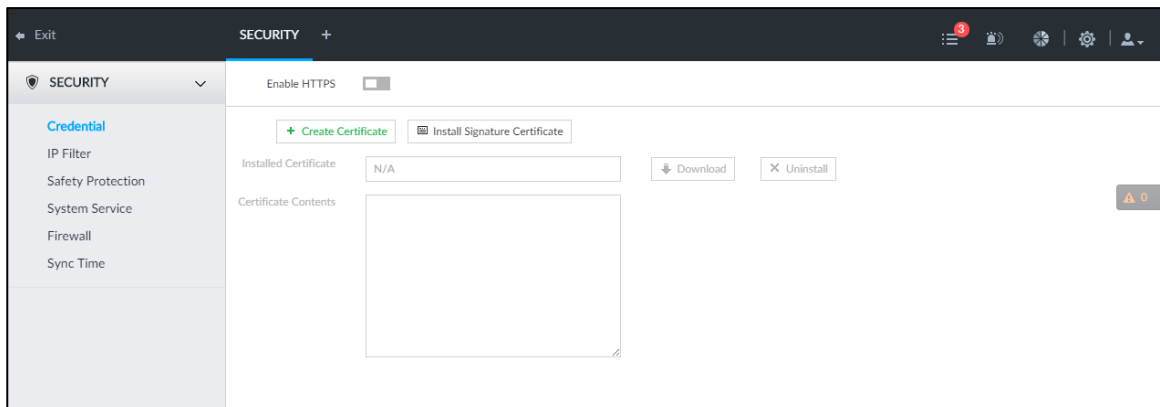


- Create and install root certificate if it is your first time to use HTTPS or you have changed device IP address.
- After creating server certificate and installing root certificate, download and install root certificate on the new PC, or download the certificate and then copy to the new PC.

Step 1 Click , or click  on the configuration interface, and then select **SECURITY > Credential**.

The **Credential** interface is displayed. See Figure 8-91.

Figure 8-91 Credential (1)



Step 2 Create certificate on the device.

- 1) Click **Create certificate**.

The **Create certificate** interface is displayed. See Figure 8-92.

Figure 8-92 Create certificate

Country !

IP/Domain !

Term of Validity days

Province

Position

Organization

Organization Unit

Email

OK Cancel

2) Set country, IP/domain, valid date and so on.



- Country, IP/domain, and valid date are required items. Other items are optional.
- IP/domain shall be the device IP or the domain.

3) Click **OK**.

System begins to install certificate, and then displays certificate information after the installation. See Figure 8-93.

Figure 8-93 Credential (2)

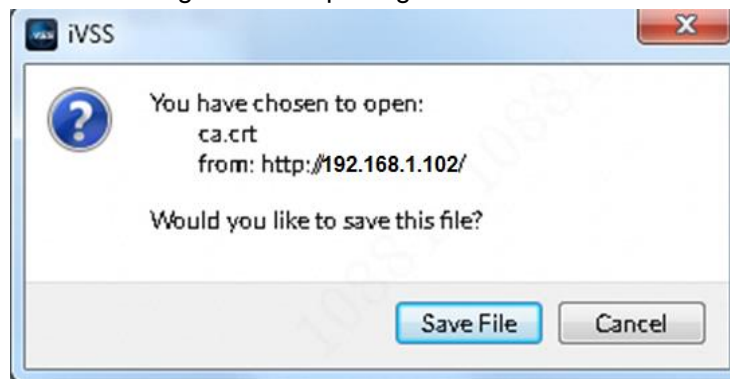


Step 3 Download certificate.

1) Click  .

The **Opening ca.crt** interface is displayed. See Figure 8-94.

Figure 8-94 Opening ca.crt



- 2) Click **Save File** to select file saved path.
- 3) Click **Save**.
System begins downloading certificate file.

Step 4 Install root certificate on the PC.

- 1) Double-click the certificate.
System displays **Open file-security warning** interface.
- 2) Click **Open**.
System displays **Certificate** interface. See Figure 8-95.

Figure 8-95 Certificate



- 3) Click **Install Certificate**.
The **Certificate Import Wizard** interface is displayed. See Figure 8-96.

Figure 8-96 Certificate import wizard



- 4) Follow the prompts to import the certificate.
System goes back to **Certificate** interface.

Step 5 Click **OK** to complete certificate installation.



8.6.1.1.2 Installing Signature Certificate

Upload signature certificate to install.

Preparation

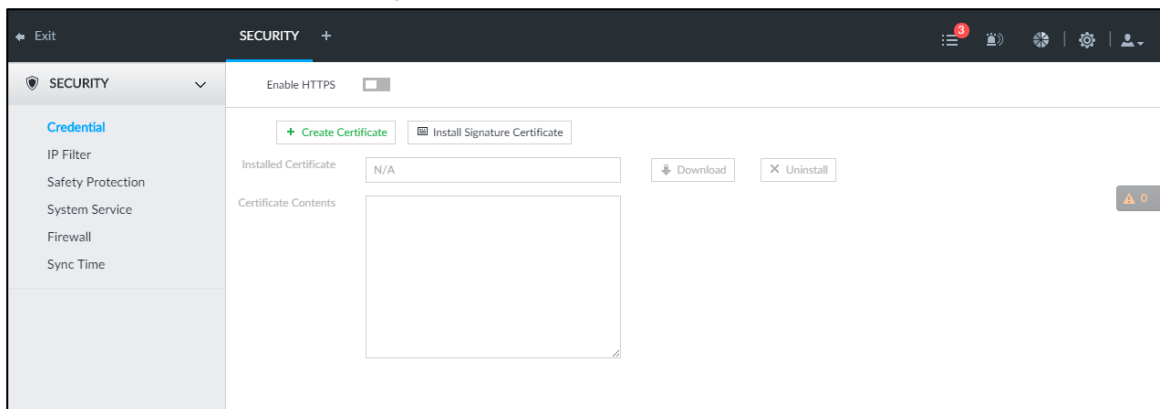
Before installation, make sure that you have obtained safe and valid signature certificate.

Operation Steps

Step 1 Click , or click  on the configuration interface, and then select **SECURITY > Credential**.

The **Credential** interface is displayed. See Figure 8-97.

Figure 8-97 Credential(1)



Step 2 Click **Install Signature Certificate**.

The **Install Signature Certificate** interface is displayed. See Figure 8-98.

Figure 8-98 Install signature certificate



Step 3 Click **Browse** and then select certificate and credential file.

Step 4 Click **Install**.

System begins to install certificate, and then displays certificate information after the installation.



Step 5 Install the root certificate on the PC. See "8.6.1.1 Installing the Created Certificate Step 4" for detailed information.



This root certificate is the one obtained with signed certificate.

8.6.1.2 Enabling HTTPS

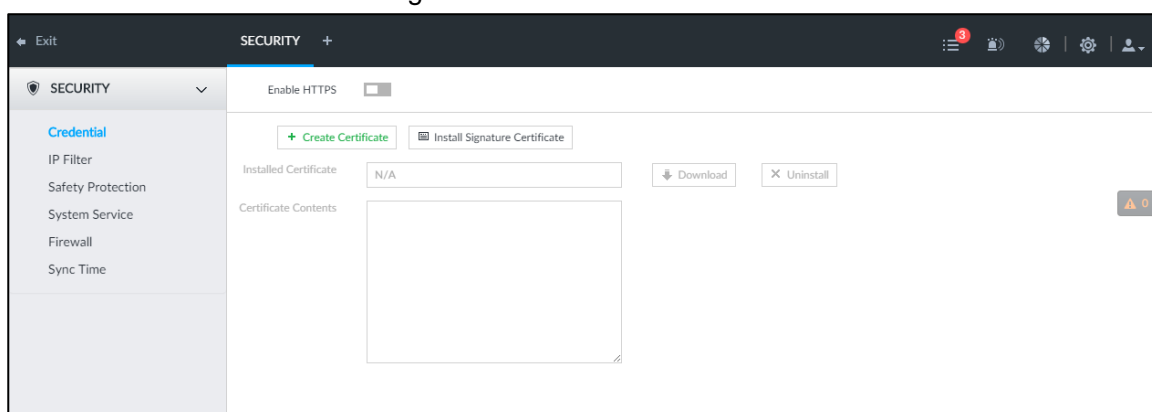
After you install the certificate and enable HTTPS function, you can use the HTTPS on the PC to access the device.

Step 1 Click , or click  on the configuration interface, and then select **SECURITY > Credential**.

The **Credential** interface is displayed.

Step 2 Click  to enable HTTPS function. See Figure 8-99.

Figure 8-99 Credential



Step 3 Click **Save**.

After you successfully save the settings, you can use HTTPS to access the web interface.

Open the browser, enter https://IP address:port in the address bar, and then press Enter, and the login interface is displayed.





- IP address is device IP or the domain name.
- Port refers to device HTTPS port number. If the HTTPS port is the default value 443, just use https://IP address to access.

8.6.1.3 Uninstalling the Certificate

Uninstall the certificate.

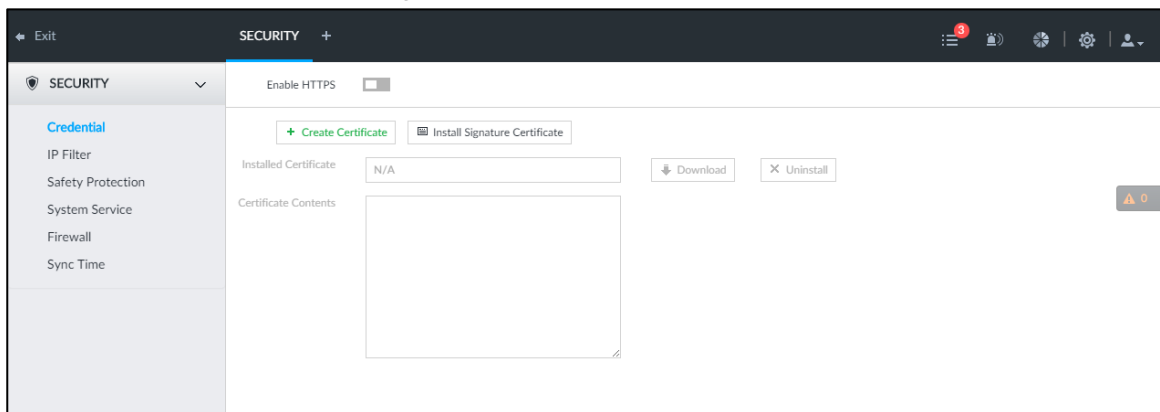


- You cannot use the HTTPS function after you uninstall the certificate.
- The certificate cannot be restored after being uninstalled. Be cautious.

Step 1 Click , or click  on the configuration interface, and then select **SECURITY > Credential**.

The **Credential** interface is displayed. See Figure 8-100.

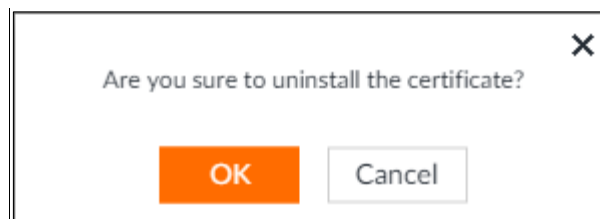
Figure 8-100 Credential



Step 2 Click **Uninstall**.

System pops up a confirmation box. See Figure 8-101.



Figure 8-101 Confirmation



Step 3 Click **OK** to uninstall the certificate.

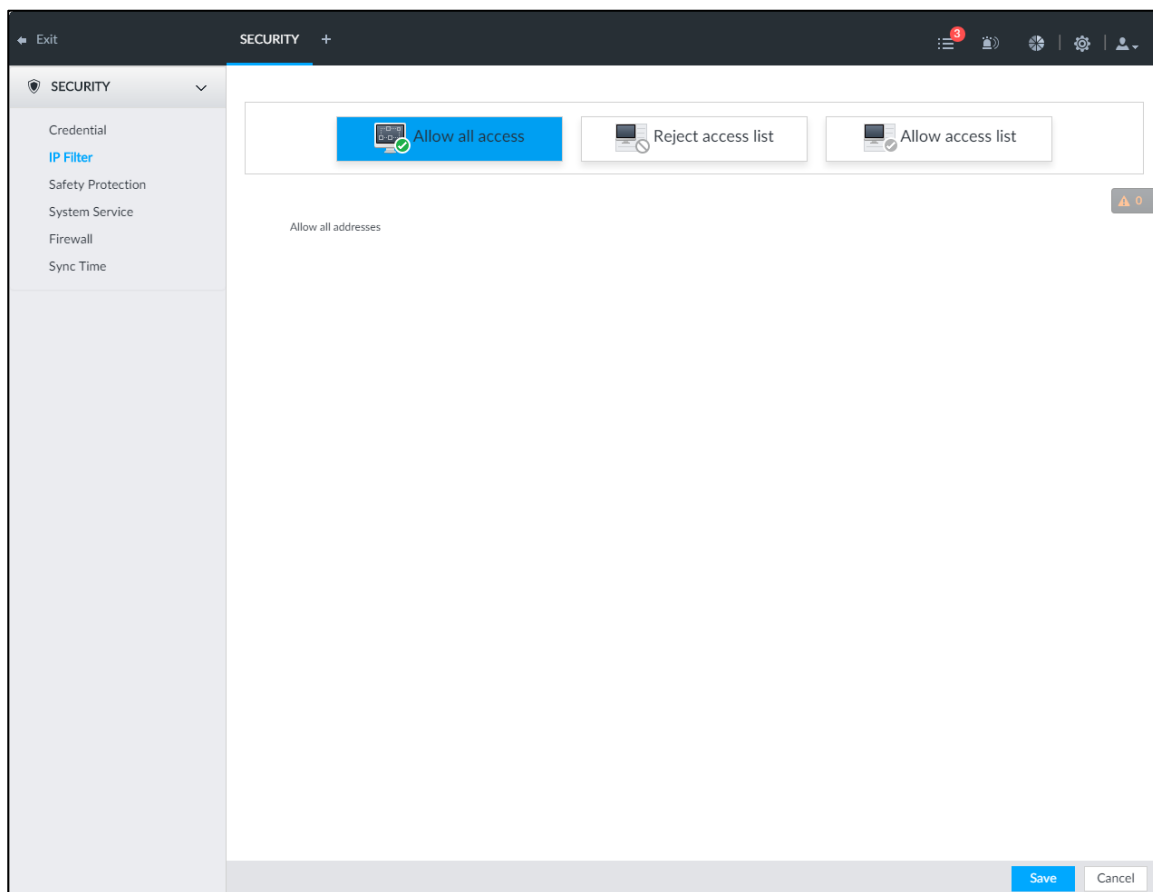
8.6.2 Configuring Access Permission

Set the specified IP addresses to access the device, to enhance device network and data security.

Step 1 Click , or click  on the configuration interface, and then select **SECURITY > IP Filter**.

The **IP Filter** interface is displayed. See Figure 8-102.

Figure 8-102 IP Filter



Step 2 Select IP access rights.

- Allow all access: It is to allow all IP addresses in the same IP segment to access the device.
- Reject access list: It means the IP address in the list cannot access the device.
- Allow access list: It means the IP address in the list can access the device.

Step 3 Add IP host.



The following steps are to set reject access list or allow access list.

1) Click **Add**.

The **Add** interface is displayed. See Figure 8-103.


Figure 8-103 Add

2) Select **Add Type**, and set IP address or MAC address of IP host.

- Single IP: Enter host IP address.

- IP segment: Enter IP segment. It can add multiple IP addresses in current IP segment.
 - MAC: Enter MAC address of IP host.
- 3) Click **OK** to add the IP host.
System displays added IP host list.





- Click **Add** to add more IP hosts.
- Click  to edit the IP host.
- Select an IP host and then click **Delete** to delete.

Step 4 Click **Save**.

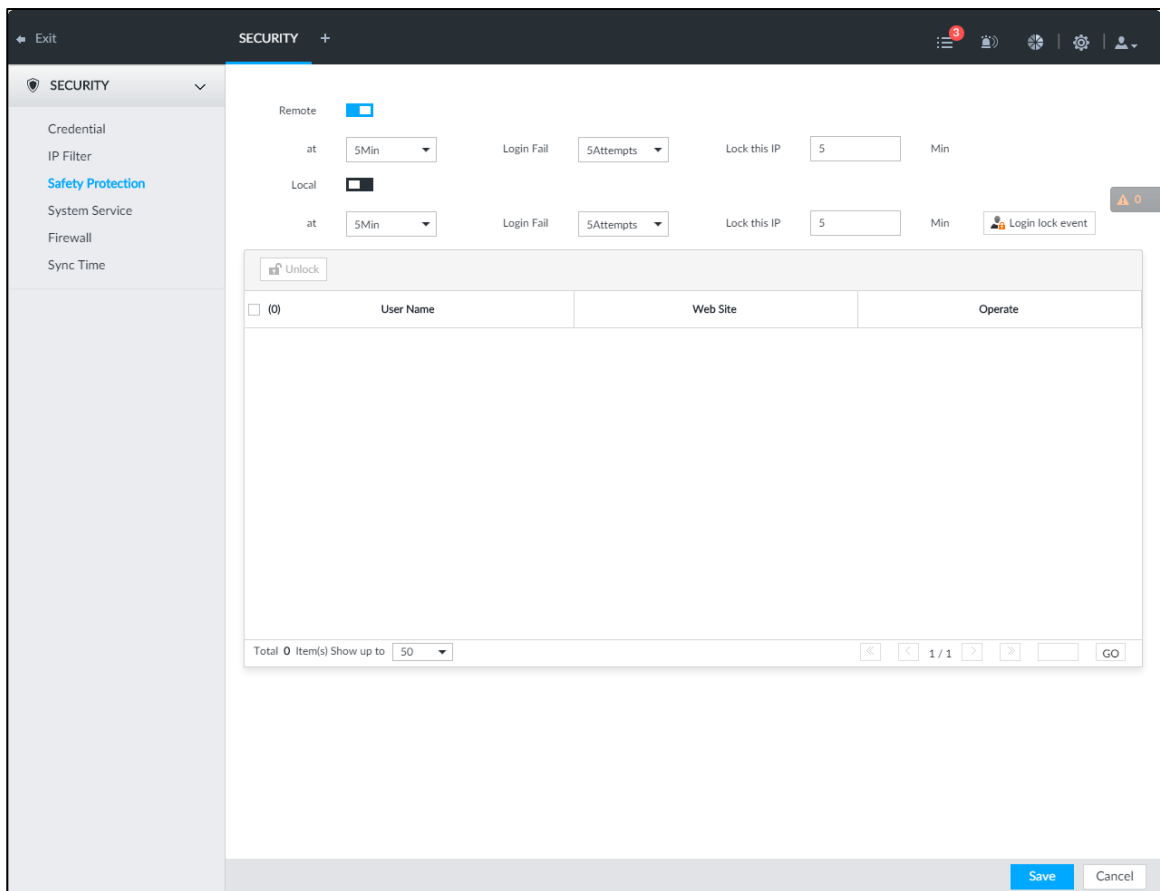
8.6.3 Safety Protection


Set the login password lock strategy once the login password error has exceeded the specified threshold. System can lock current IP host for a period of time.

Step 1 Click , or click  on the configuration interface, and then select **SECURITY > Safety Protection**.

The **Safety Protection** interface is displayed. See Figure 8-104.

Figure 8-104 Safety protection (1)




Step 2 Click  to enable security protection function.

- Remote: When you are using web interface, PCAPP to access the device remotely, once the login password error has exceeded the threshold, system locks the IP host for a period of time.
- Local: When you are accessing local menu of the device, once the login password error has exceeded the threshold, system locks the account for a period of time.

Step 3 Set lock strategy according to the actual situation.



Step 4 Click **Save**.

Once the IP host has been locked, you can view the locked IP host on the list. Select an IP host and then click **Unlock**, or click the  of the corresponding IP host to unlock.

Step 5 (Optional) Click **Login lock event** to go to the **Event** interface where you can select **Abnormal Event > Lock in** to configure a **Lock in** event.

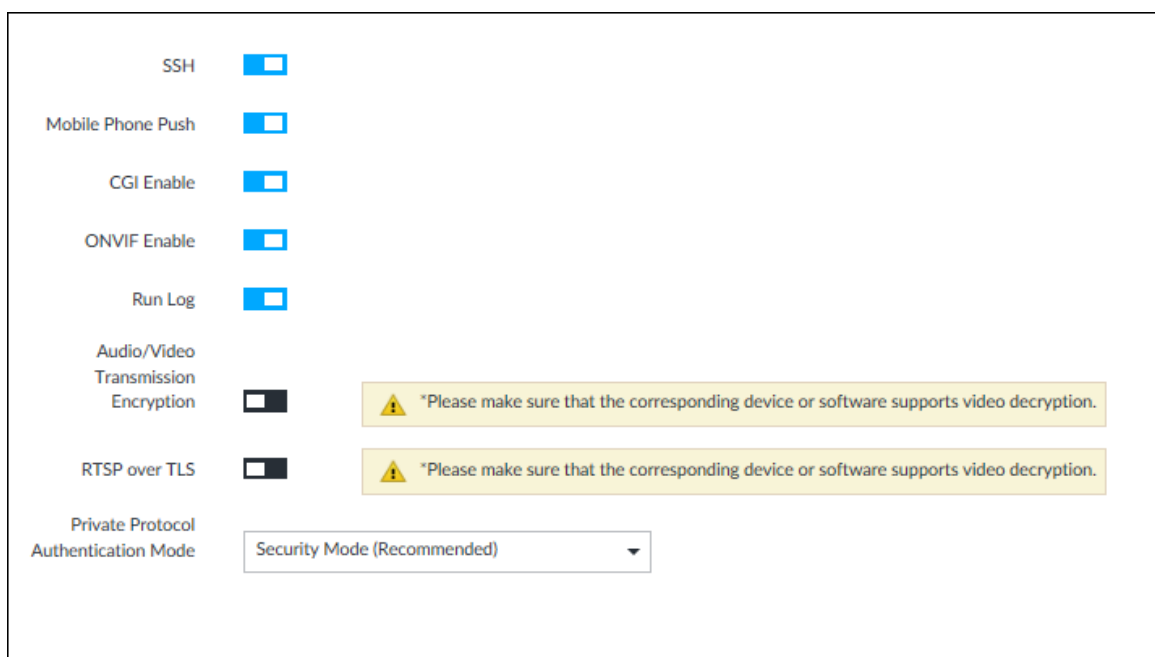
8.6.4 Enabling System Service Manually

Enable system services for third-party access.

Step 1 Click , or click  on the configuration interface, and then select **SECURITY > System Service**.







The **System Service** interface is displayed. See Figure 8-105.

Figure 8-105 System service



Step 2 Enable or disable system service according to your actual situation. See Table 8-30 for detailed information.

Table 8-30 System service



System service	Description
SSH	<p>After enabling this function, you can access IVSS through SSH protocol to carry out system debugging and IP configuration. This function is disabled by default.</p>  <p>You are recommended to disable this function. Otherwise there might be security risks.</p>
Mobile Phone Push	<p>After enabling this function, you can access IVSS with mobile phone client to receive information from IVSS.</p>  <p>You are recommended to disable this function. Otherwise there might be security risks.</p>
CGI Enable	<p>After this function is enabled, third-party platform can connect IVSS through CGI protocol.</p>  <p>You are recommended to disable this function. Otherwise there might be security risks.</p>
ONVIF Enable	<p>After this function is enabled, other devices can connect IVSS through ONVIF protocol.</p>  <p>You are recommended to disable this function. Otherwise there might be security risks.</p>
Run Log	<p>After enabling it, you can view system running logs in Intelligent Diagnosis > Run Log.</p>
Audio/Video Transmission Encryption	<p>When this function is enabled, stream transmission will be encrypted.</p>  <p>You are recommended to enable this function. Otherwise you might risk data leakage.</p>
RTSP over TLS	<p>Enable this function to encrypt stream transmission.</p>  <p>You are recommended to enable this function. Otherwise you might risk data leakage.</p>
Private Protocol Authentication Mode	<p>Select a private protocol authentication mode between security mode and compatible mode. Compatible mode is recommended.</p>

Step 3 Click **Save**.

8.6.5 Configuring Firewall

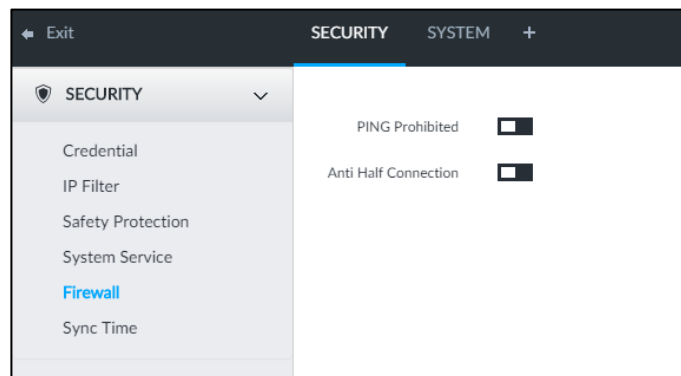
Enhance network and data security by prohibiting Ping and half-connection.

- **PING Prohibited**: When **PING Prohibited** is enabled, the device does not respond to Ping requests.
- **Anti Half Connection**: When **Anti Half Connection** is enabled, and the device can provide service normally under half-connection attack.

Step 1 Click , or click  on the configuration interface, and then select **SECURITY > Firewall**.

The **Firewall** interface is displayed. See Figure 8-106.

Figure 8-106 Firewall





Step 2 Click  to enable PING Prohibited or Anti Hal Connection.

Step 3 Click **Save**.

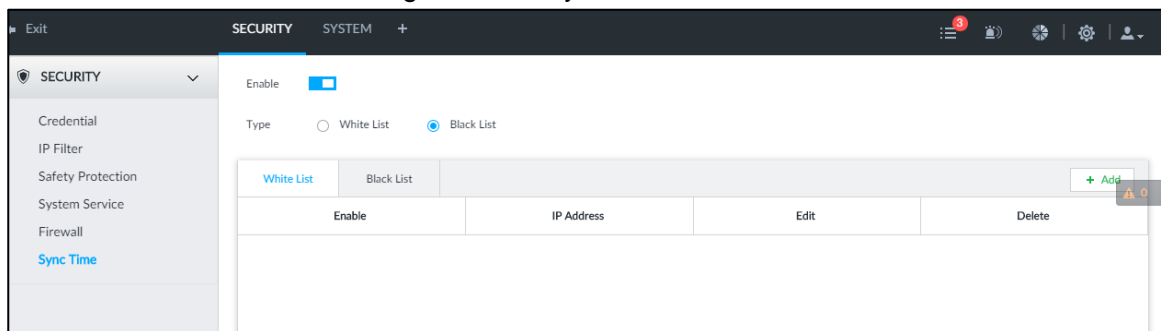
8.6.6 Configuring Time Synchronization Permission


Configure permissions of time synchronization actions from other devices or servers.

Step 1 Click , or click  on the configuration interface, and then select **SECURITY > Synch Time**.

The **Synch Time** interface is displayed. See Figure 8-107.

Figure 8-107 Sync time



Step 2 Click  to enable time synchronization restriction.

Step 3 Select **White List** or **Black List**.

- Hosts in the white list have the permission to synchronize time of the Device.
- Hosts in the white list cannot synchronize time of the Device.

Step 4 On the **White List** interface or the **Black List** interface, add hosts.

- 1) Click **Add**. The following interface is displayed. See Figure 8-108.





Figure 8-108 Add a host

- 2) Select an IP version, and then enter an IP address.
- 3) Click **OK**.

Step 5 Click **Save**.

You can also perform the following functions after configuring the whitelist or blacklist. See Table 8-31.

Table 8-31 Other functions

Function	Description
Edit IP address	Click  to edit IP address.
Delete IP address	Click  to delete a host from the list.
Configure IP address permission	Click the corresponding  of each host, so as to enable the whitelist or balcklist configuration for the host. Click  to disable the whitelist or balcklist configuration for the host.

8.7 Account Management

Device account adopts two-level management mode: user and user group. You can manage their basic information. To conveniently manage the user, we recommend the general user authorities shall be lower than high-level user authorities.



- To ensure device safety, enter correct login password to operate Account interface (for example, add or delete user).
- After a correct login password is entered on Account interface, if you do not close Account interface, you can do other operations directly. If you close the interface and enter it again, you shall enter the correct login password again. The actual interface shall prevail.



8.7.1 User Group

Different users might have different authorities to access the device. You can divide the users to different groups. It is easy for you to maintain and manage the user information.


- System supports maximum 64 user groups. User group name supports maximum 64 characters.
- System has two default user groups (read-only): admin and ONVIF.

- Create new user group under the root.

Adding User Group

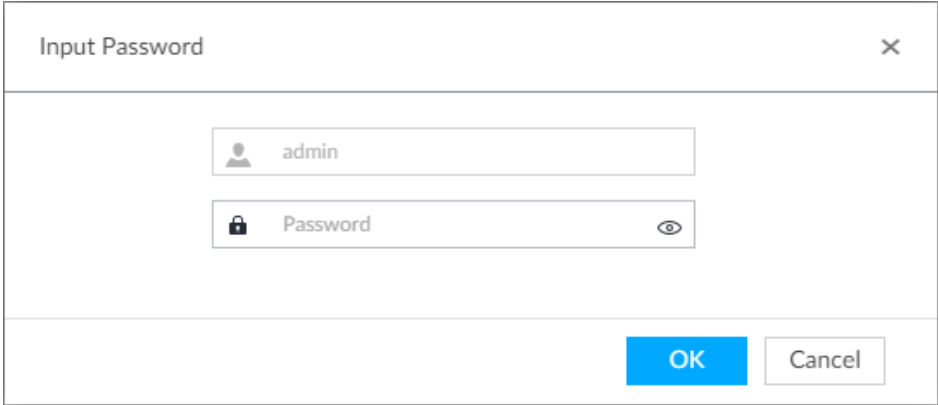
Step 1 Click , or click  on the configuration interface, and then select **ACCOUNT**.

The **Account** interface is displayed.

Step 2 Select the root node in the device tree on the left and then click  at the lower-left corner.

The **Input Password** is displayed. See Figure 8-109.

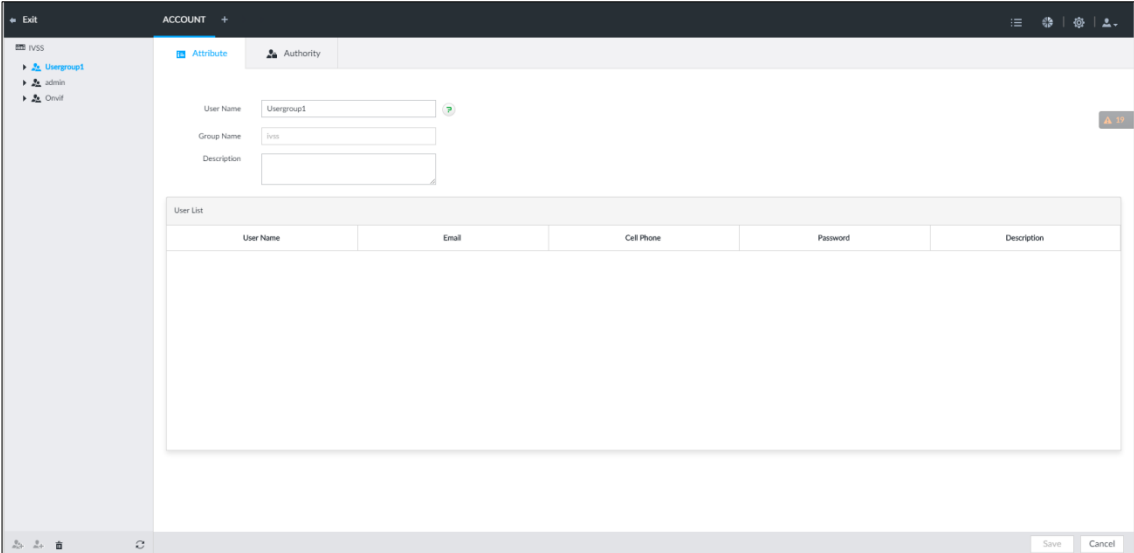
Figure 8-109 Input password



Step 3 Enter current user's login password, and then click **OK**.

System creates one user group and displays **Property** interface. See Figure 8-110.

Figure 8-110 User group property



Step 4 Set parameters. For details, see Table 8-32.

Table 8-32 User group

Parameters	Description
Name	Set user group name. The name ranges from 1 to 64 characters. It can contain English letters, number and special character ("_", "@", ".").

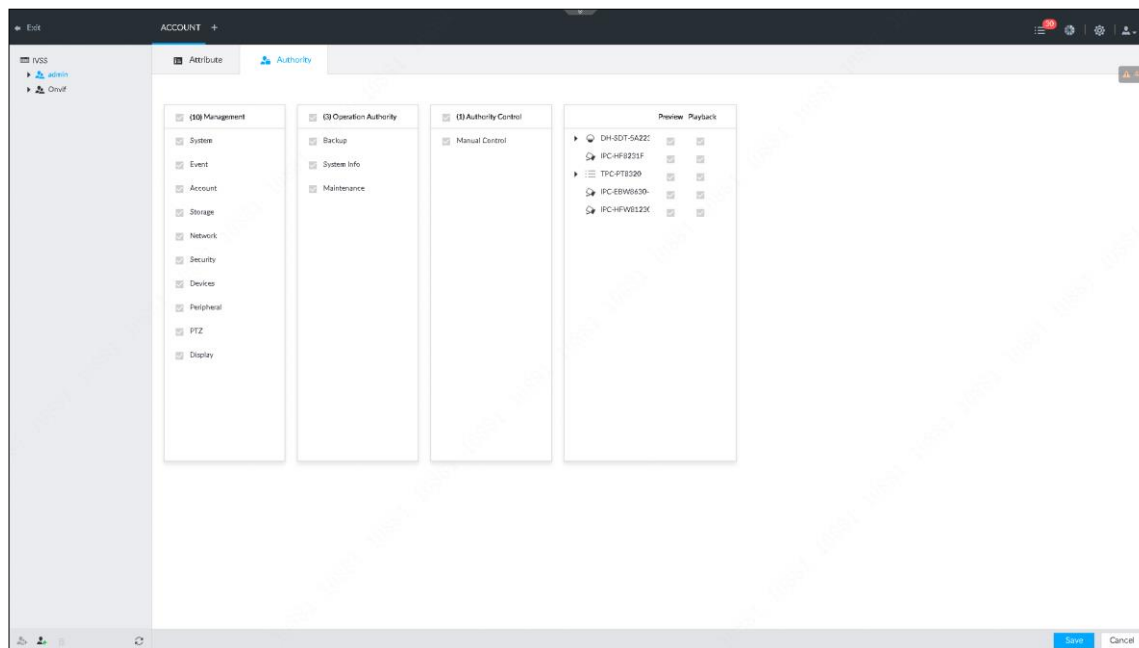
Parameters	Description
Group name	Displays user group organization node. System automatically recognizes the group name.
Description	Enter user group description information.
User list	Displays user information of current group.

Step 5 Select user authority.

- 1) Click **Authority** tab.

The **Authority** interface is displayed. See Figure 8-111.

Figure 8-111 Authority



- 2) Set user group authorities according to actual situation.

- : means it has the corresponding authority.
- Check the box at the top of the authority list (such as (0) Authority Control) to select all authorities of current category.

Step 6 Click **Save**.


Deleting User Group



- Before you delete a user group, delete all users of current group first. User group cannot be restored after being deleted. Be cautious.
- Admin and ONVIF user cannot be deleted.

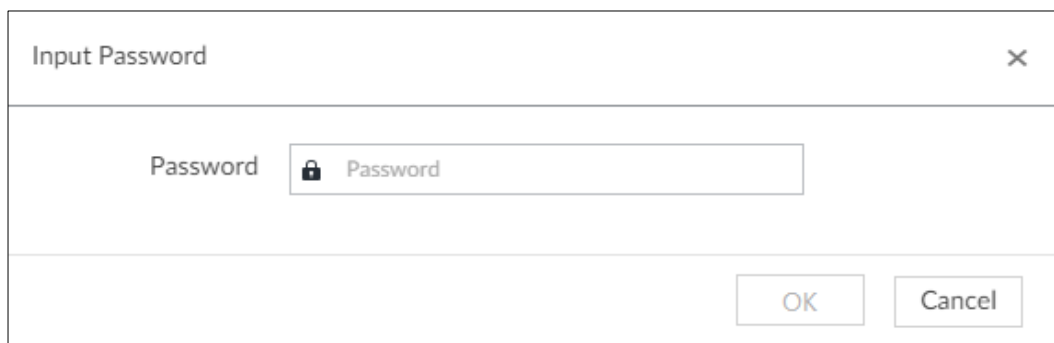
Step 1 Click , or click  on the configuration interface, and then select **ACCOUNT**.

The **Account** interface is displayed.

Step 2 Select user group and click .

The **Input Password** interface is displayed. See Figure 8-112.

Figure 8-112 Input password



Step 3 Enter current user's login password, and then click **OK**.

The following prompt interface is displayed.

Step 4 Click **OK**.

8.7.2 Device User

The device user is to access and manage the device. System default administrator is admin. It is to add a user and then set corresponding authorities, so that the user can access the resources within its own rights range only.




User authorities adopt the user group authorities settings. It is read-only.

Adding a user

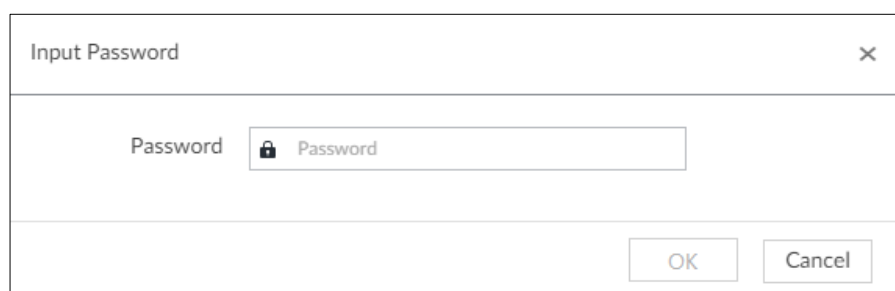
Step 1 Click , or click  on the configuration interface, and then select **ACCOUNT**.

The **Account** interface is displayed.

Step 2 Select admin user group or other newly added user group, and then click  at the lower-left corner.

The **Input Password** is displayed. See Figure 8-113.

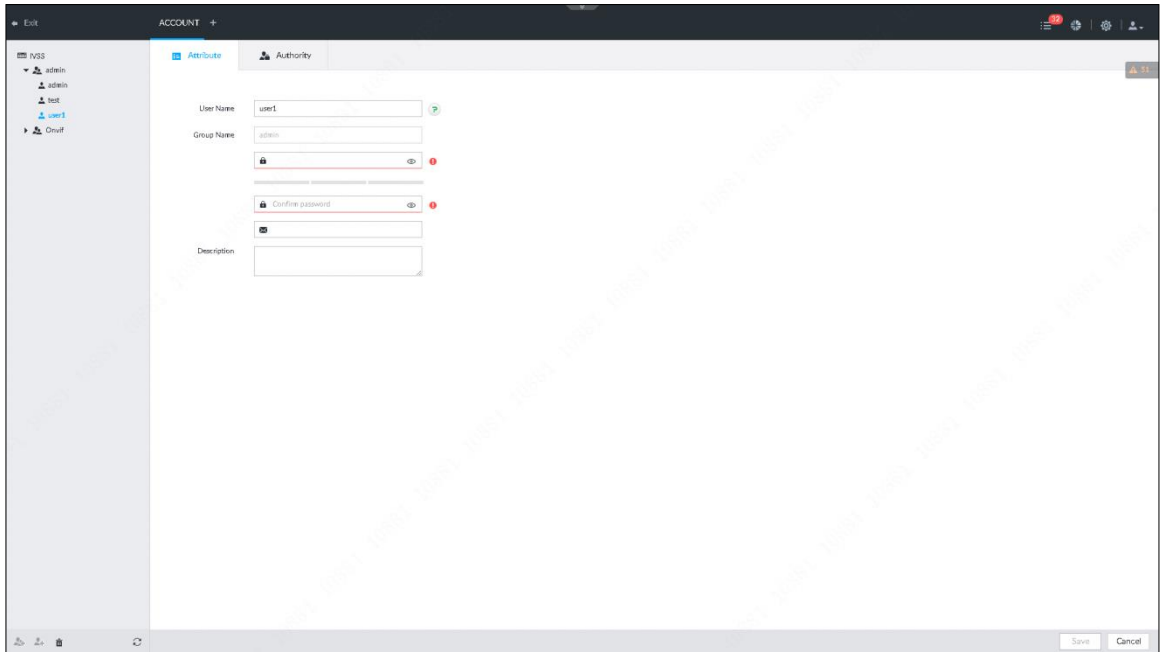
Figure 8-113 Input password



Step 3 Enter current user's login password, and then click **OK**.

The **Property** interface is displayed. See Figure 8-114.

Figure 8-114 Property



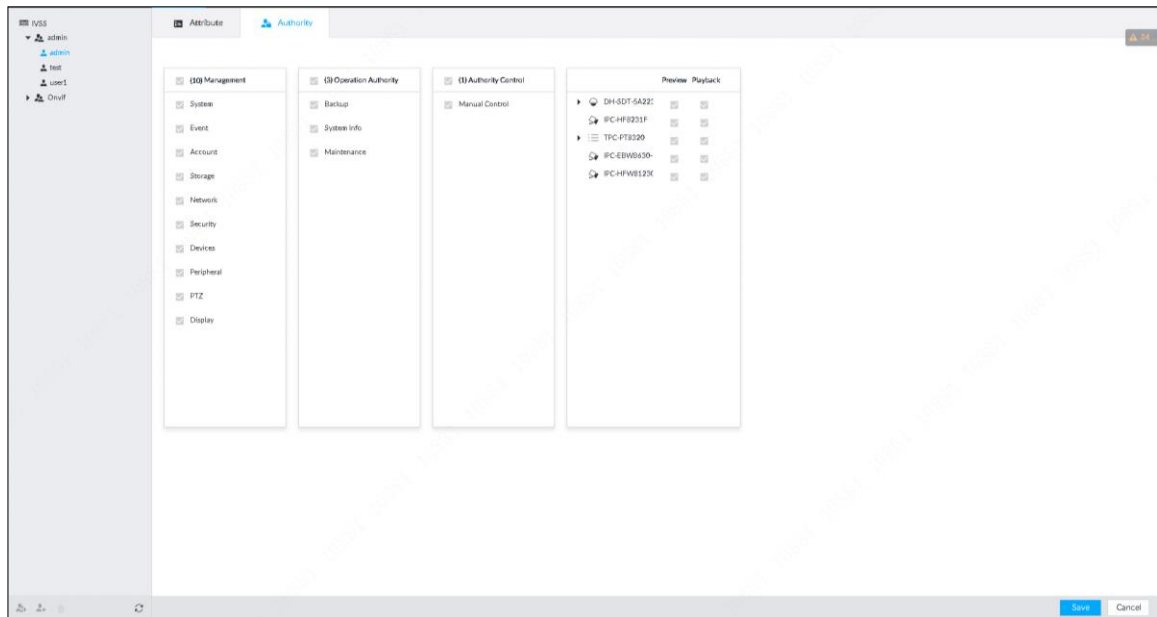
Step 4 Set parameters. For details, see Table 8-33.

Table 8-33 User management

Parameters	Description
Name	Set user name. The name ranges from 1 to 31 characters. It can contain English letters, number and special character ("_", "@", ".").
Group name	Displays user organization node. System automatically identifies it.
Password	In the new password box, enter the new password and enter it again in the Confirm Password box.
Confirm Password	The password ranges from 8 to 32 non-empty characters. It can contain letters, numbers and special characters (excluding ' " ; : & and space) .The password shall contain at least two categories. Usually we recommend the strong password.
Description	Enter user description information.

Step 5 (Optional) Click **Authority** tab to view user authority.

Figure 8-115 Authority



Step 6 Click **Save**.



Operation

After adding a user, you can modify user information or delete the user. For details, see Table 8-34.



The user with account management authority can change its own and other users' information.

Table 8-34 User operation

Name	Operation
Edit user information	Select a user from user list. The Property interface of the user is displayed, and the user's login password and description information can be modified.
Delete User	<p>Select a user from user list, and then click  to delete.</p> <p></p> <ul style="list-style-type: none"> Before deleting an online user, block the user first. For details, see "10.5 Online User." User information cannot be restored after being deleted. Be cautious.

8.7.3 Password Maintenance

Maintain and manage user's login password.

8.7.3.1 Modifying Password

Modify user's login password.

Modifying Password of the Current User


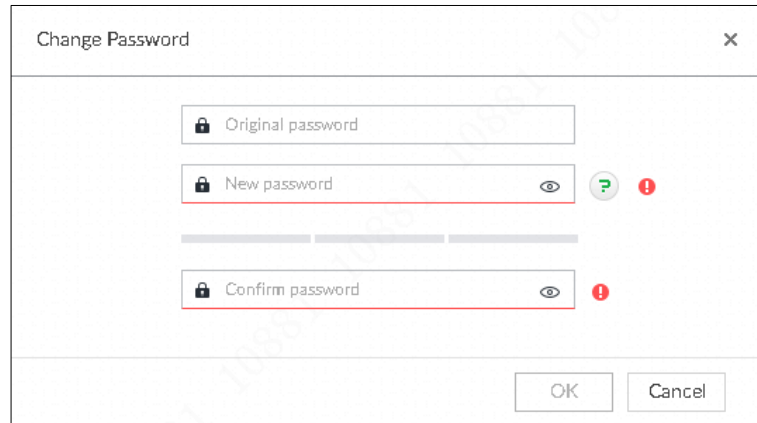
- Step 1** Click  at the top right corner, and then select **Modify Password**.
The **Change Password** interface is displayed. See Figure 8-116.

Figure 8-116 Modify password





The 'Change Password' dialog box contains three password input fields: 'Original password', 'New password', and 'Confirm password'. Each field has a lock icon on the left and an eye icon on the right. The 'New password' and 'Confirm password' fields are highlighted with a red border. To the right of the 'New password' field are three icons: a green question mark, a green checkmark, and a red exclamation mark. To the right of the 'Confirm password' field is a red exclamation mark. At the bottom right of the dialog are 'OK' and 'Cancel' buttons.

- Step 2** Input old password and then enter new password and then confirm.
Step 3 Click **OK**.

Modifying Password of Other User

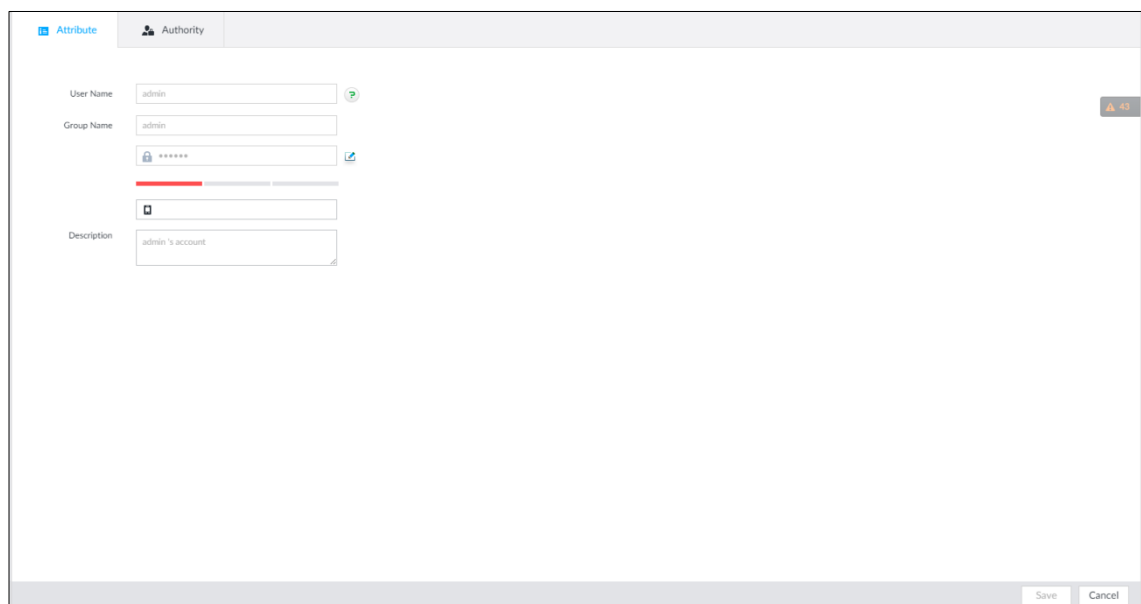


Only **Admin** account supports this function.


- Step 1** Click , or click  on the configuration interface, and then select **ACCOUNT**.
The **Account** interface is displayed.

- Step 2** Select a user.
The **Property** interface is displayed. See Figure 8-117.

Figure 8-117 Property



The 'Property' configuration interface shows fields for 'User Name', 'Group Name', and 'Description'. The 'User Name' field contains 'admin' and has a green question mark icon. The 'Group Name' field contains 'admin'. Below the 'Group Name' field is a password field with a lock icon and a blue key icon. The 'Description' field contains 'admin's account'. At the bottom right are 'Save' and 'Cancel' buttons. A small warning icon is visible in the top right corner of the interface.

- Step 3** Click .

The **Input Password** interface is displayed. See Figure 8-118.

Figure 8-118 Input password

Step 4 Enter current user's login password, and then click **OK**.

The **Change Password** interface is displayed. See Figure 8-119.

Figure 8-119 Modify password

Step 5 In the **New Password** box, enter the new password and enter it again in the **Confirm Password** box.

Step 6 Click **OK**.

8.7.3.2 Resetting Password

You can use email address or answer the security questions to reset password once you forgot it. You can only reset password on the local interface of the Device.



When password resetting function is not enabled, the password cannot be reset if the security questions are not set.

Leaving Email Address and Setting Security Questions


Enable the password reset function, leave an email address and set security questions. You can only use the local interface to set security questions.

Step 1 Click , or click  on the configuration interface, and then select **ACCOUNT**.

The **Account** interface is displayed.

Step 2 Select the root node in the device tree on the left.

The **Password Reset** interface is displayed.

Step 3 Click  to enable the password reset function.

Step 4 Enter an email address for resetting password.

Step 5 Set security questions. Only available on the local interface of the Device.

Step 6 Click **Save**.

Resetting Password on Local Interface

Step 1 Connect a display to the Device, and then go to the **Login** interface of device. See Figure 8-120.

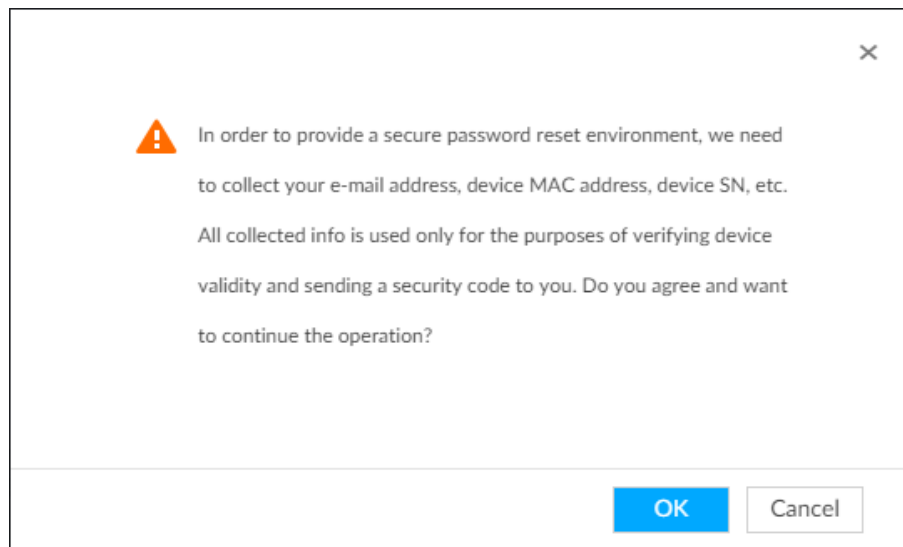
Figure 8-120 Login



Step 2 Click **Forgot Password**.

System pops up a confirmation box. See Figure 8-121.

Figure 8-121 Prompt interface



Step 3 Click **OK**.

- If you have set the email address information, the QR code interface is displayed.

- If you have not set the email address information, the email address interface is displayed. See Figure 8-122. After you set the email address information and click **Next**, the QR code interface is displayed. See Figure 8-123.

Figure 8-122 Enter email address

Reset Password

1 Password Protection 2 Retrieve Password 3 Set New Password

Email (To reset password)

Next Cancel

Figure 8-123 Scan QR code

Reset Password

1 Retrieve Password 2 Set New Password

Retrieve Password

SN *****Q00019

Scan QR Code

Scan the code on your current interface

1. Use specified APP (DMSS) to scan, APP can automatically send out the data to the server
2. Use non-specified APP to scan, please send QR Code to support_rpwd@global.dahuatech.com

Use specified APP to scan, security code will send to 1***@qq.com Email

Input Security Code

Next Cancel

Step 4 Reset the password.

- Use email address
Scan the QR code to obtain the security code according to system prompts. Enter the security code that you received in the security code box. Enter the email address in the email address box.



- ◇ You can get security codes twice by scanning the same QR code. If you need to get the security code once again, refresh the interface.
- ◇ Use the security code to reset the password within 24 hours; otherwise the security code becomes invalid.
- Answer security questions
On the QR code interface, in the **Retrieve Password** drop-down list, select **Security Questions**, and the security questions interface is displayed, see Figure 8-124. In the **Answer** boxes, enter the correct answers.

Figure 8-124 Security questions

Reset Password

1 Retrieve Password 2 Set New Password

Retrieve Password Retrieve Password ▼

Question 1 What is your favorite book during your childhood

* Answer

Question 2 What was the first name of your first boss?

* Answer

Question 3 What is the name of your favorite fruit?

* Answer

Next Cancel



Step 5 Click **Next**.

The new password setting interface is displayed. See Figure 8-125.

Figure 8-125 New password setting

Step 6 Set parameters. For details, see Table 8-35.

Table 8-35 Description of password parameters

Parameters	Description
User	The default user name is admin.
Password	In the New Password box, enter the new password and enter it again in the Confirm Password box.
Confirm Password	The new password can be set from 8 through 32 non-empty characters and contains at least two types from number, letter and special characters (excluding ' " ; : & and space). Enter a strong password according to the password strength indication.
Prompt question	After setting the prompt, when you move the mouse to  on the login interface, the system pops up a prompt to help you remember the password.  The prompt question function is for local login interface only. See the actual interface for detailed information.

Step 7 Click Confirm Modify.

You can log in with the new password.

8.7.4 ONVIF

When the remote device is connecting with the device through ONVIF protocol, use the verified ONVIF account.



- System adopts three ONVIF user groups (admin, user and operator). You cannot add ONVIF user group manually.
- You cannot add user under ONVIF group directly.

Adding ONVIF User

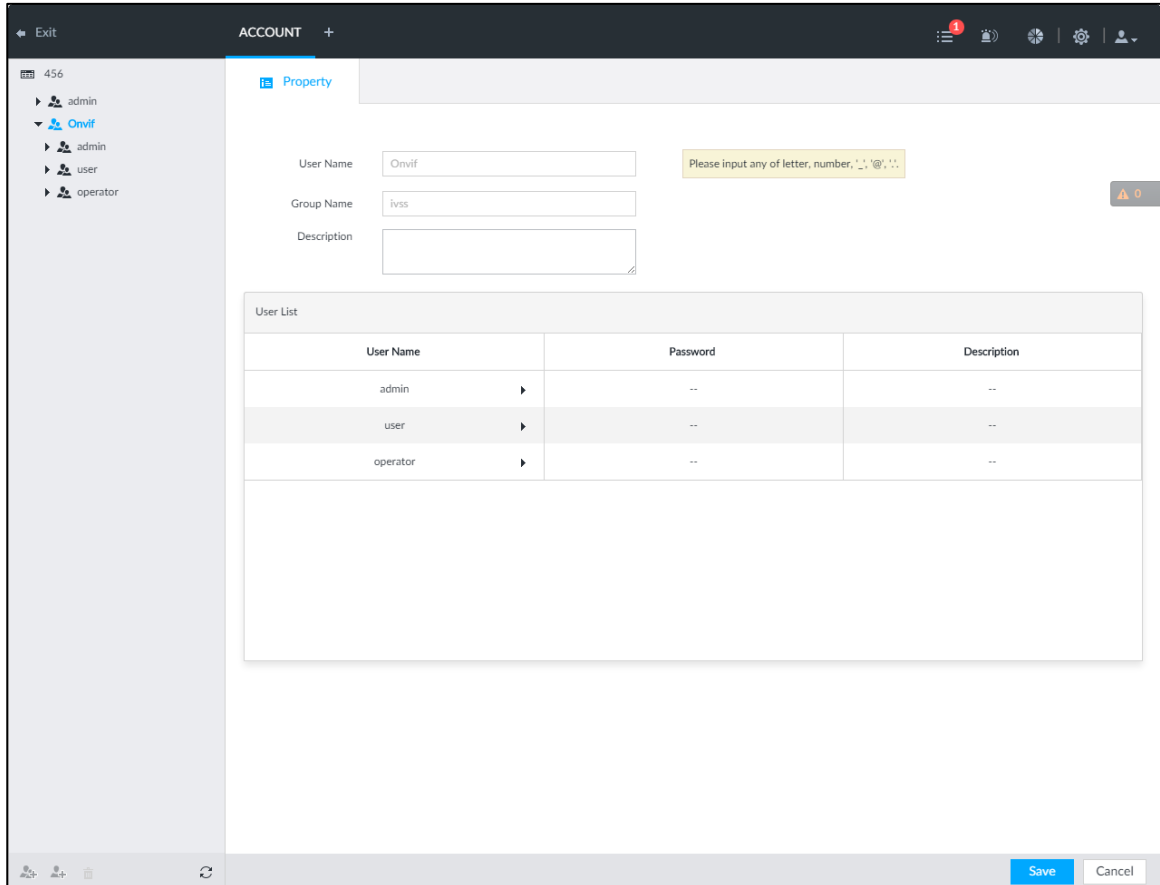
Step 1 Click  or click  on the configuration interface, and then select **ACCOUNT**.

The **Account** interface is displayed.


Step 2 Select user group under ONVIF.

The **Property** interface of ONVIF group is displayed. See Figure 8-126.

Figure 8-126 ONVIF

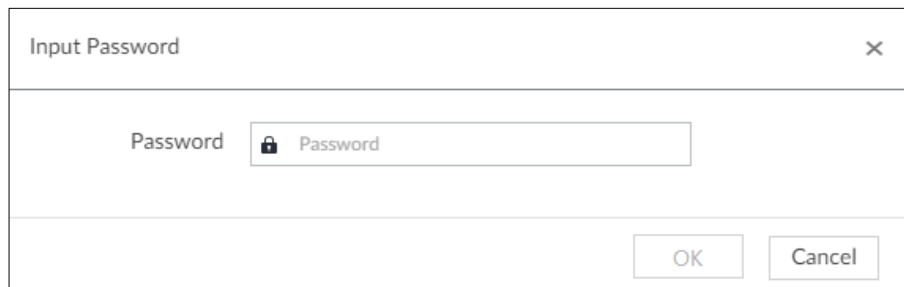


User Name	Password	Description
admin	--	--
user	--	--
operator	--	--

Step 3 Click  at the lower-left corner of the **Property** interface.

The **Input Password** interface is displayed. See Figure 8-127.

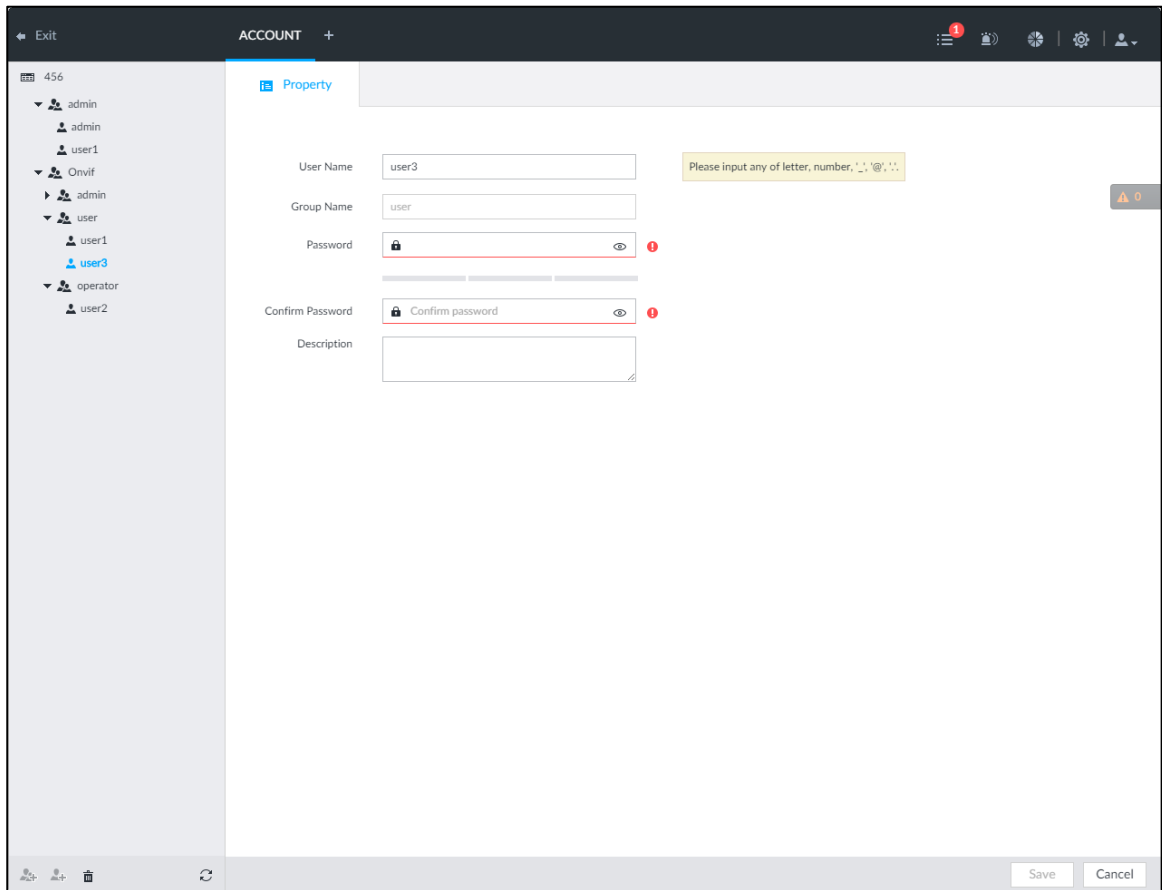
Figure 8-127 Input password



Step 4 Enter the login password of current user, and then click **OK**.

The **Property** interface is displayed. See Figure 8-128.

Figure 8-128 ONVIF property



Step 5 Set parameters. For details, see Table 8-36.

Table 8-36 ONVIF parameters description

Parameters	Description
User Name	Set ONVIF user name. The name ranges from 1 to 31 characters. It can contain English letters, number and special character (_ @ .).
Group name	Displays user organization node. System automatically identifies it.
Password	Set ONVIF user password. The password ranges from 8 to 32 non-empty characters. It can contain letters, numbers and special characters (excluding ' " ; : & and space) .The password shall contain at least two categories. Usually we recommend the strong password.
Confirm Password	
Description	Enter ONVIF user description information.

Step 6 Click **Save**.

Delete ONVIF User



Deleting the admin account is not supported.

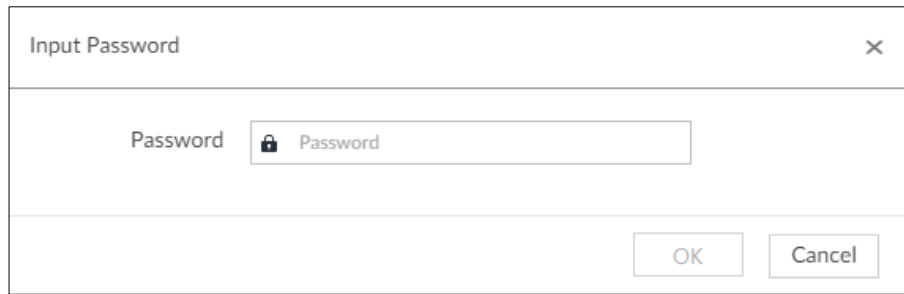
Step 1 Click , or click  on the configuration interface, and then select **ACCOUNT**.

The **Account** interface is displayed.

Step 2 Select an ONVIF user and click .

The **Input Password** interface is displayed. See Figure 8-129.

Figure 8-129 Input password



A dialog box titled "Input Password" with a close button (X) in the top right corner. It contains a label "Password" followed by a text input field with a lock icon and the placeholder text "Password". At the bottom right, there are two buttons: "OK" and "Cancel".

Step 3 Enter current user's login password, and then click **OK**.

The following prompt interface is displayed.

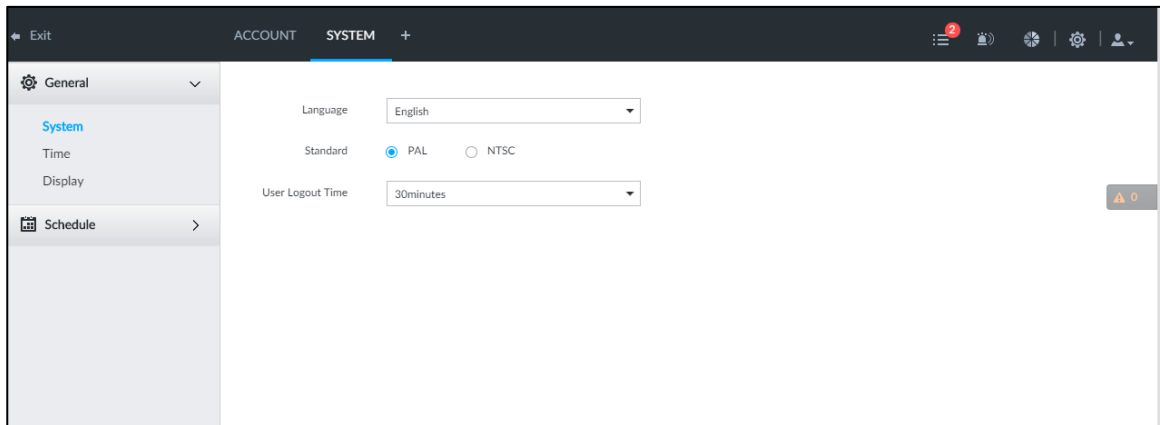
Step 4 Click **OK**.

8.8 System Configuration

Click  or click  on the configuration interface, select **SYSTEM**. The **SYSTEM** interface is displayed. See Figure 8-130.



Set system basic settings, such as general parameters, time, display parameter, schedule, and voice.

Figure 8-130 System management



8.8.1 Setting System Parameters

Set system language, standard, user logout time, virtual keyboard, and mouse moving speed.





Step 1 Click , or click  on the configuration interface, and then select **SYSTEM > General > System**.

The **SYSTEM** interface is displayed. See Figure 8-131.

Figure 8-131 Configuring system settings

Step 2 Set parameters. For details, see Table 8-37.



Table 8-37 System parameters description

Parameters	Description
Language	Set system language.
Standard	<p>Select video standard.</p> <ul style="list-style-type: none"> • PAL is mainly used in China, Hong Kong, Middle East and Europe. • NTSC is mainly used in Japan, United States of America, Canada and Mexico. <p> As a technical standard of processing video and audio signals, PAL and NTSC mainly differ in encoding, decoding mode and field scanning frequency.</p>
User Logout Time	<p>Set auto logout interval once you remains inactive for a specified period or the device exceeds the set value. After auto logout, the user needs to login again to operate.</p> <p>If you select No Logout, system does not automatically log out.</p>
Sync Remote Device	<p>Click  to enable the function. If enabled, the language, standard and time settings configured here will be synchronized to all the connected remote devices.</p>
Virtual Keyboard	<p>Enable virtual keyboard function on the local menu. See "Appendix 1.2 Virtual Keyboard" for detailed information.</p> <p> This function is for local menu only.</p>
Mouse Moving Speed	<p>Set mouse moving speed on the local interface.</p> <p> This function is for local menu only.</p>

Step 3 Click **Save**.

8.8.2 System Time

Set system time, and enable NTP function according to your need. After enabling NTP function, device can automatically synchronize time with the NTP server.



Step 1 Click , or click  on the configuration interface, and then select **SYSTEM > General > Time**.

The **Time** interface is displayed. See Figure 8-132.

Figure 8-132 Time

Step 2 Set parameters. For details, see Table 8-38.

Table 8-38 System parameters description

Parameters	Description
Time	<p>Set system date and time. You can set manually or set device to synchronize time with the NTP server.</p> <ul style="list-style-type: none"> Manual Setting: Select Manual Setting and then set the actual date and time in the following two ways. <ul style="list-style-type: none"> Click , and then set the time and date in the calendar. Click Sync to synchronize device time with your PC.  <ul style="list-style-type: none"> When using IE11, Google Chrome75 or Firefox61 and later versions, on the web interface of the Device, click Sync to synchronize both device time and time zone with the PC. When using earlier versions of browser, on the web interface of the Device, click Sync to synchronize only device time with PC. Sync with the Internet Time Server: Select the check box, enter NTP server IP address or domain, and then set Auto Sync Time Interval.

Parameters	Description
Time and Date Format	Set time and date display format.
Time Zone	Set device time zone.
Auto Time Synchronization	After enabling this function, IVSS detects system time of remote device once in every interval. When time of remote device is inconsistent with IVSS time, IVSS will calibrate the time of remote device automatically.

Step 3 (Optional) Set DST.





DST is a system to stipulate local time, in order to save energy. If the country or region where the device is located follows DST, you can enable DST to ensure that system time is correct.

- 1) Click to enable DST.
- 2) Select DST mode. It includes **Date** and **Week**.
- 3) Set DST start time and end time.

Step 4 Click **Save**.

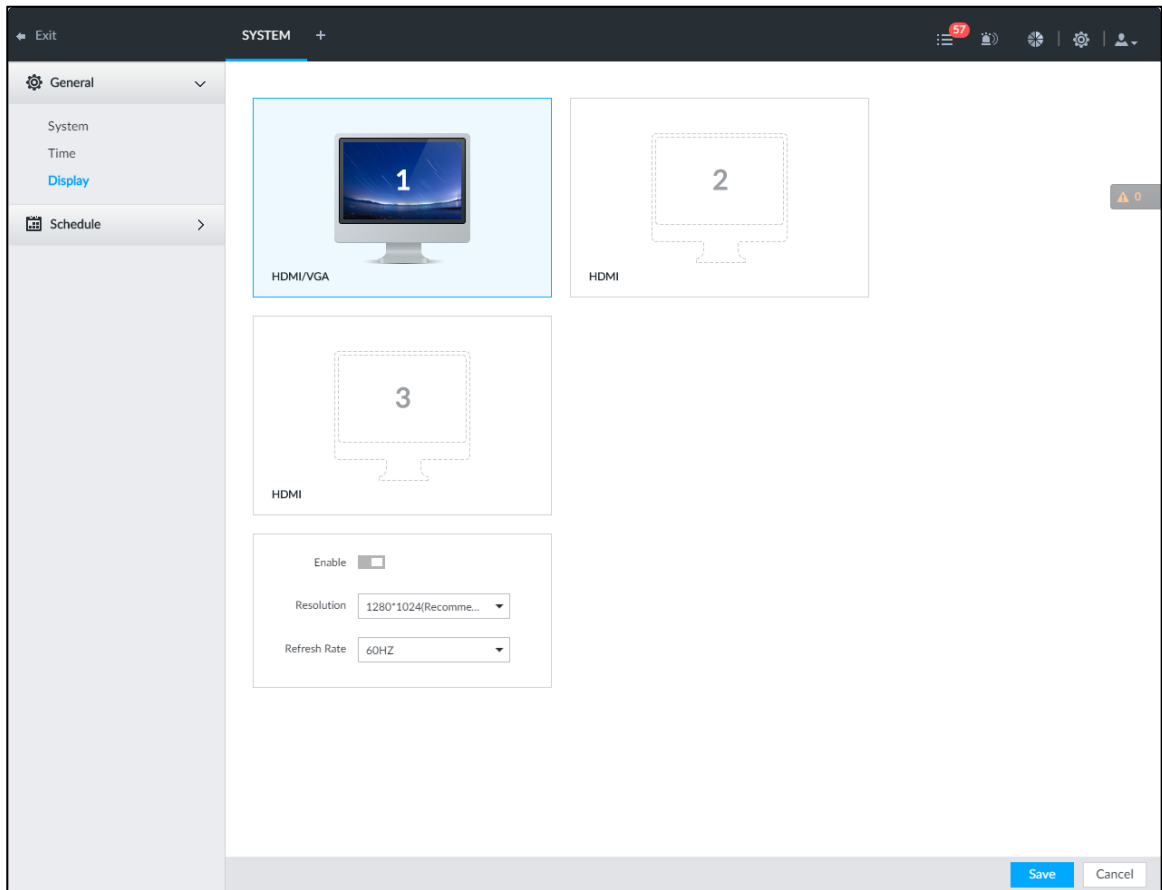
8.8.3 Display

Set connected display resolution and refresh rate.

Step 1 Click , or click  on the configuration interface, and then select **SYSTEM > General > Display**.

The **Display** interface is displayed. See Figure 8-133.

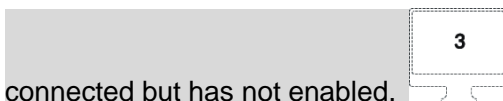
Figure 8-133 Display



- SN 1–3 refers HDMI 1–HDMI 3. Among which, HDMI/VGA is the main display, while the VGA and HDMI 1 outputs the same video.
- VGA and HDMI 1 are outputting the same video source. Three HDMI ports can output different video sources.



- means display is connected and enabled.



connected but has not enabled. means display is disconnected.

Step 2 Select a display.

Step 3 Click to enable the selected display.

Step 4 Set parameters. For details, see Table 8-39.

Table 8-39 Display parameters description

Parameters	Description
Resolution	Set display resolution. Different displays support different resolutions. See your actual interface for detailed information.
Refresh rate	Set refresh rate of the display.



Step 5 Click **Save**.

8.8.4 Schedule

Set schedule. When you are configuring alarm, record arm/disarm period, system can call the schedule directly. System only triggers the corresponding operations during the specified schedule.

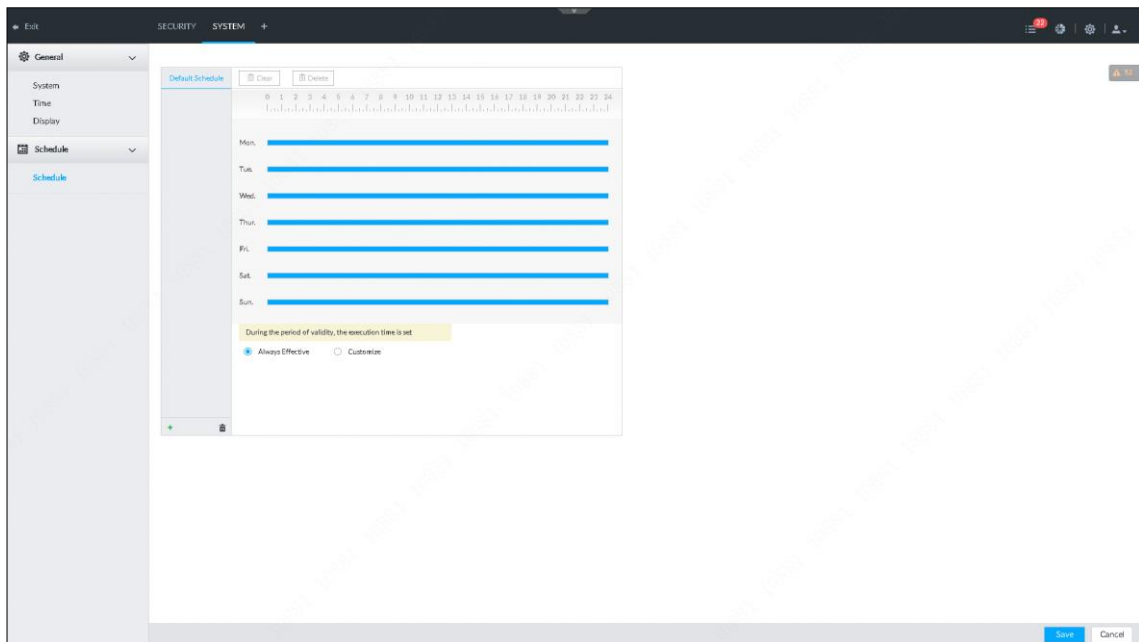


Default schedule has been created by default. Default schedule is **Always Effective**, and cannot be modified or deleted.

Step 1 Click , or click  on the configuration interface, and then select **SYSTEM > Schedule > Schedule**.

The **Schedule** interface is displayed. See Figure 8-134.

Figure 8-134 Schedule



Step 2 Add schedule.

1) Click .

The **Add Schedule** interface is displayed. See Figure 8-135.

Figure 8-135 Adding schedule

- 2) Set schedule name.
- 3) Click **OK** to save the configuration.



Step 3 Set valid time period. It includes **Always Effective** and **Customize**.

Step 4 Set validity period of schedule.




- The step is for customized mode only.
- Each calendar supports maximum 50 validity periods.
- The blue area on the time bar means the validity period.

On the time bar, you can:

- Click the blue area, and  is displayed. Drag  to adjust the start time and end time of validity period.
- Press the any blank space on the time bar, and drag to the right to add a validity period.
- Click **Clear** to clear all validity periods of current schedule.
- Select a validity period, and then click **Delete** to delete the period.

Step 5 Click **Save**.



Select an added schedule, and then click  to delete.

8.9 Cluster Service

The cluster function, also known as cluster redundancy, is a kind of deployment method that can improve the reliability of device. In the cluster system, there is a number of master devices and another number of slave devices (the N+M mode), and they have a virtual IP address (the cluster IP) for unified login and management. Under normal circumstances, the master devices are in the working state. When the master device fails, the corresponding slave device will take over the job automatically. When the master device recovers, the slave device will transmit the configuration data, cluster IP address and videos recorded during the failure to the master device which then takes over the job again.

In the N+M cluster system, there is a management server, the DCS (Dispatching Console) server, which is responsible for timely and correct scheduling management of the main and slave devices.

When you create a cluster, the current IVSS is used as the first slave device and the DCS server by default.

8.9.1 Configuring Cluster

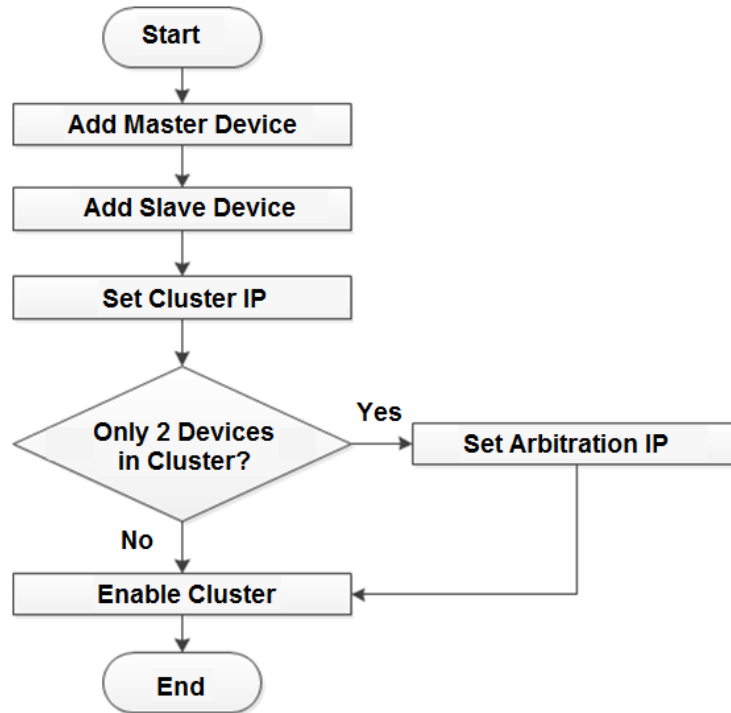
Create cluster, view cluster details, recover master devices and configure the arbitration IP address.



8.9.1.1 Creating a Cluster

Creating a cluster is to add multiple devices into a cluster that requires the addition of master and slave devices and the configuration of cluster IP. For the procedure, see Figure 8-136.

When you create a cluster, the current Device is taken as the first slave device and the DCS server by default, and the priority of the other slave devices is determined by the order in which they are added, with the first slave device being the highest priority.

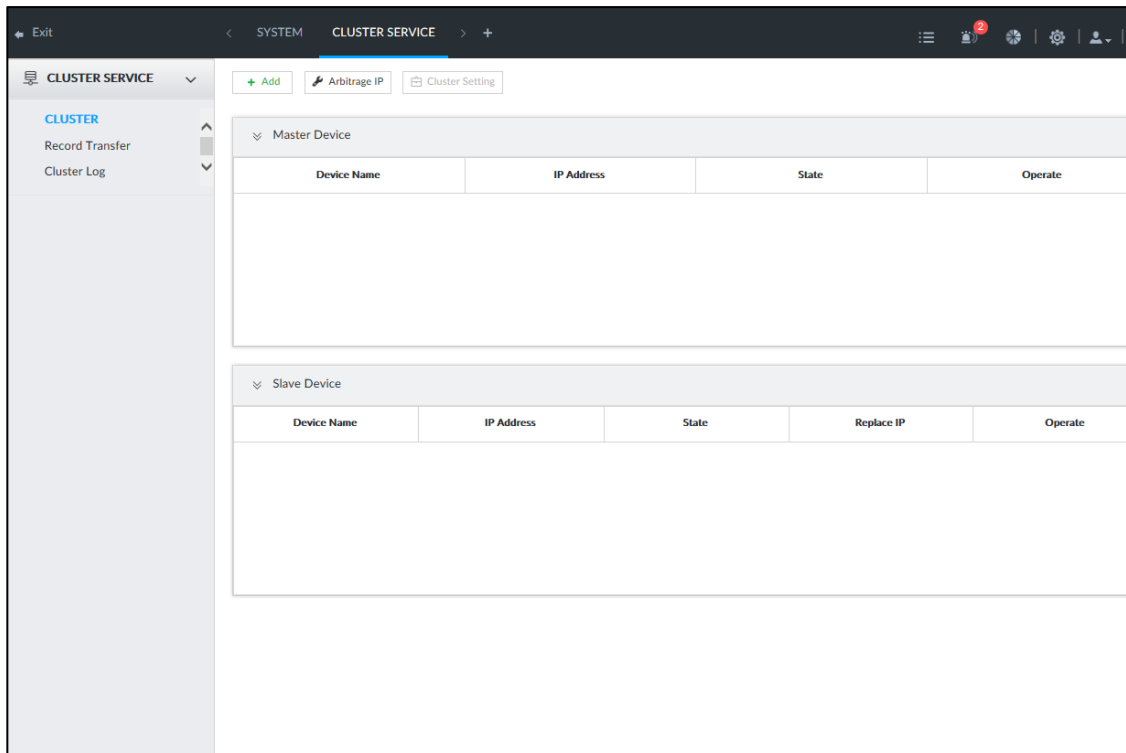
Figure 8-136 Procedure of creating a cluster



Step 1 Click , or click  on the configuration interface, and then select **CLUSTER SERVICE > CLUSTER**.

The **CLUSTER** interface is displayed. See Figure 8-137.

Figure 8-137 Configure cluster



Step 2 Add a master device or slave device.


1) Click **Add**.

The **Add** interface is displayed. See Figure 8-138.

Figure 8-138 Add cluster

2) Set parameters. See Table 8-40.

Table 8-40 Parameters description

Parameters	Description
Device Type	Select master device, or slave device as needed.
Device Name	Name the device.
IP Address	Enter the IP address of the master device or slave device.  When adding the first slave device, you need not enter the IP address, because the first slave device is the current device by default.
Port	37777 by default.
User Name	Username and password of the device, which are also used to log in to the web interface or PCAPP.
Password	

3) Click **OK**.

Step 3 Click **Start Cluster**.



For a cluster of only 2 devices, you must set the arbitration IP address. For details. See "8.9.1.3 Configuring Arbitration IP."

Step 4 Set cluster IP address.

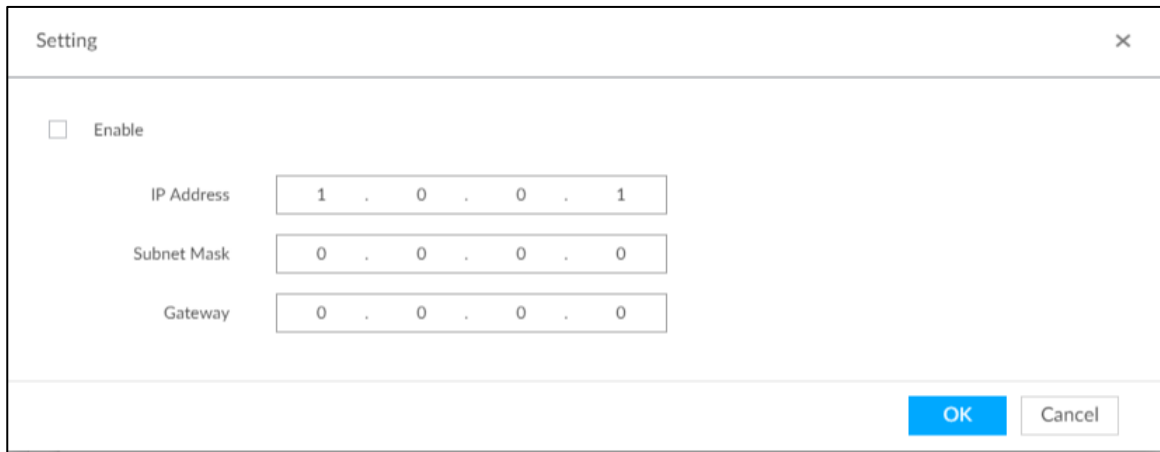


Cluster IP is a virtual IP that is used to access and manage the main devices and slave devices in the cluster. After logging in with the virtual IP, when the main device fails and the system is switched to the slave device, you can still view live video.

1) Click **Cluster Setting**.

The **Setting** interface is displayed. See Figure 8-139.

Figure 8-139 Set cluster IP



The image shows a 'Setting' dialog box with a close button (X) in the top right corner. It contains an 'Enable' checkbox which is currently unchecked. Below it are three input fields for IP configuration: 'IP Address' with the value '1 . 0 . 0 . 1', 'Subnet Mask' with the value '0 . 0 . 0 . 0', and 'Gateway' with the value '0 . 0 . 0 . 0'. At the bottom right, there are two buttons: 'OK' (highlighted in blue) and 'Cancel'.

- 2) Select the **Enable** check box, and then set the other parameters as required.
- 3) Click **OK**.

8.9.1.2 Viewing Details


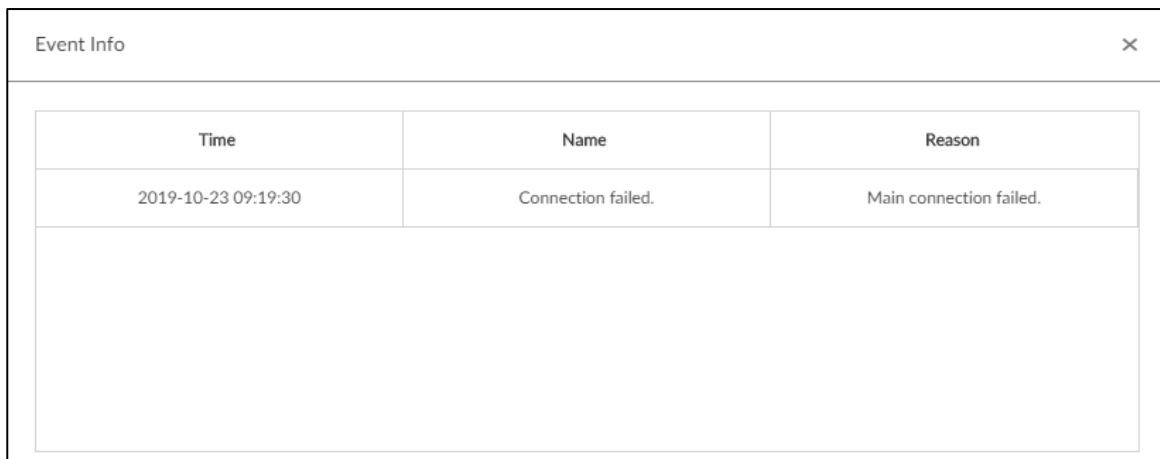
Click  that corresponds to a master or slave device to view device event logs including event time, name and details.

Figure 8-140 Event log





The image shows an 'Event Info' dialog box with a close button (X) in the top right corner. It contains a table with three columns: 'Time', 'Name', and 'Reason'. The table has one row of data.

Time	Name	Reason
2019-10-23 09:19:30	Connection failed.	Main connection failed.

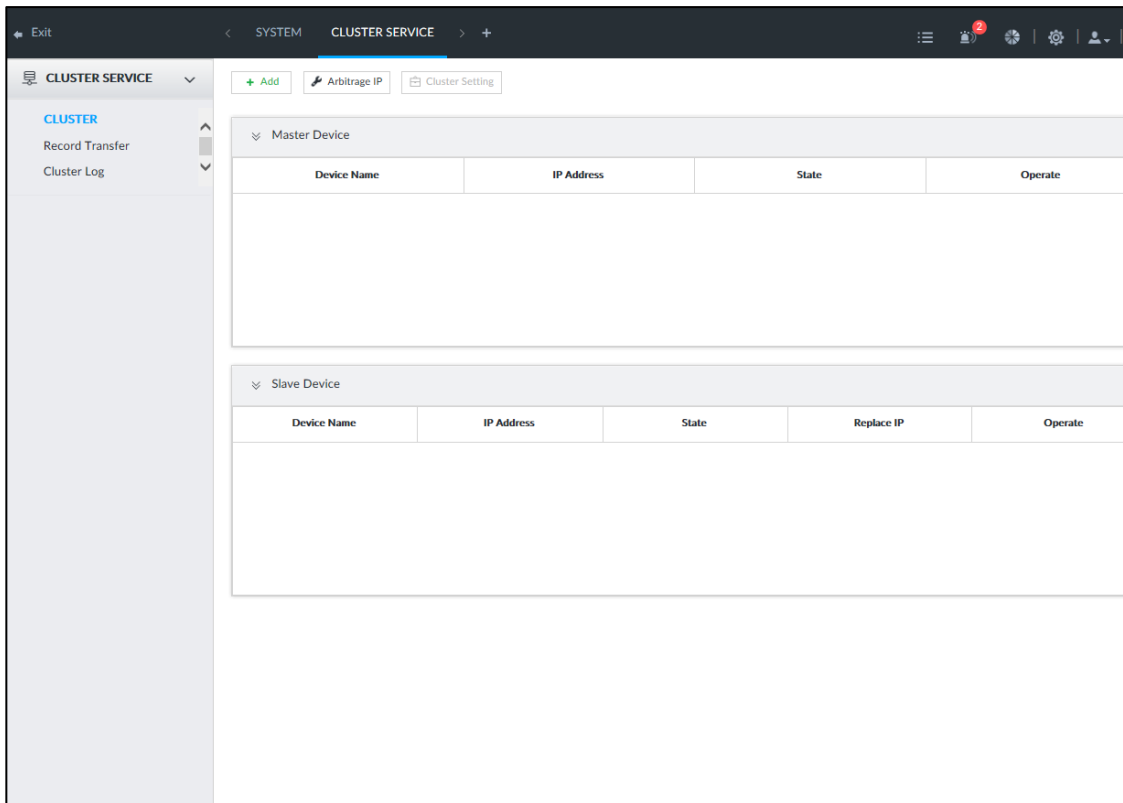
8.9.1.3 Configuring Arbitration IP

When there are only 2 devices in the cluster, a third-party device is required to determine whether the master device is faulty, so arbitration IP must be set for the cluster to perform a normal replacement operation. The arbitration IP can be the IP address of another device, PC or gateway that is connected to the device.

Step 1 Click , or click  on the configuration interface, and then select **CLUSTER SERVICE > CLUSTER**.

The **CLUSTER** interface is displayed. See Figure 8-141.

Figure 8-141 Configure cluster



Step 2 Click **Arbitrage IP**.

The **Arbitrage IP** interface is displayed. See Figure 8-142.

Figure 8-142 Set arbitration IP





Step 3 Set the preferred IP and alternate IP.

Step 4 Click **OK**.

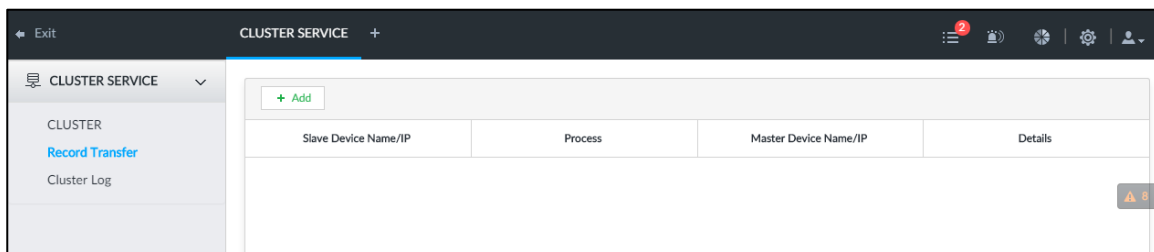
8.9.2 Record Synchronization

After the master device has recovered, the recordings on the slave device during the failure period need to be transmitted back to the master device.

Step 1 Click , or click  on the configuration interface, and then select **CLUSTER SERVICE > Record Transfer**.

The **Record Transfer** interface is displayed. See Figure 8-143

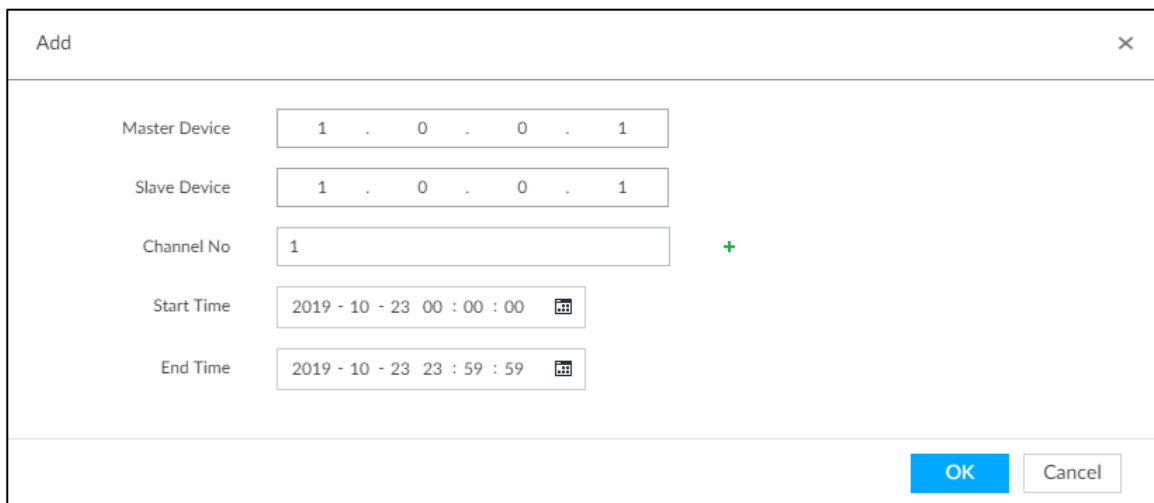
Figure 8-143 Video transfer



Step 2 Click **Add**.

The **Add** interface is displayed. See Figure 8-144.

Figure 8-144 Add



Step 3 Set parameters. See Table 8-41.

Table 8-41 Parameters

Parameters	Description
Master IP	Master device IP.
Slave IP	Slave device IP.
Channel No.	Select the channel of which the video is to be transferred. Click + to set the channel range.
Start Time	The start and end time of the video.
End Time	

Step 4 Click **OK**.

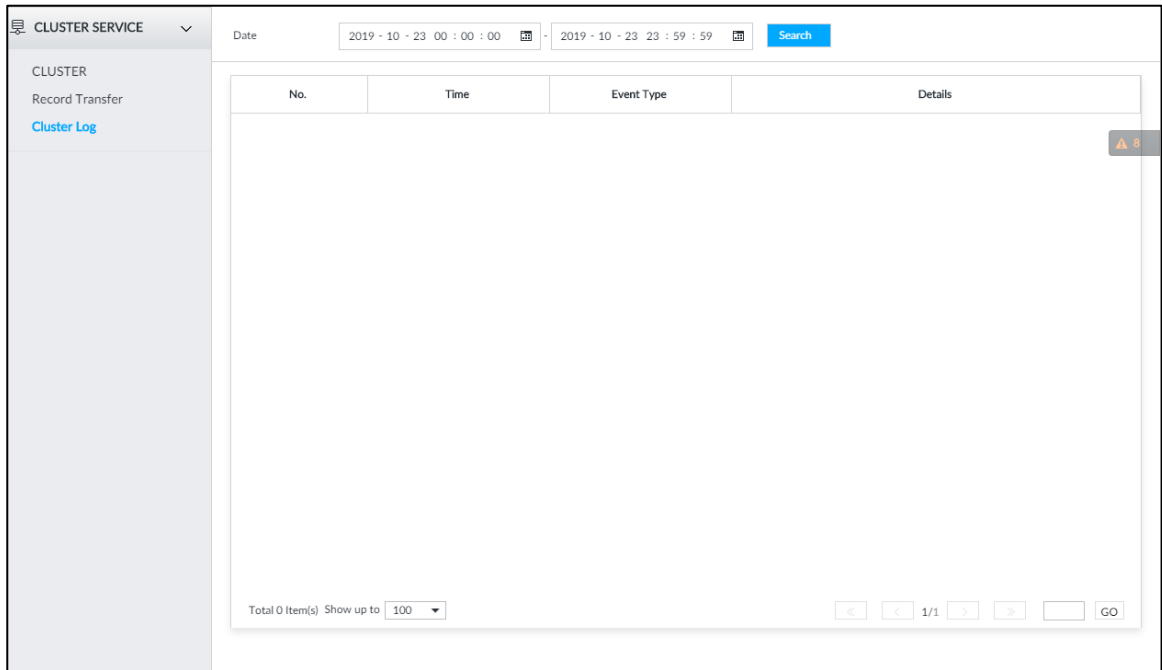
8.9.3 Viewing Cluster Log

Step 1 Click , or click  on the configuration interface, and then select **CLUSTER**

SERVICE > Cluster Log.

The **Cluster Log** interface is displayed. See Figure 8-145.

Figure 8-145 Cluster log



Step 2 Set search time, and then click **Search**.
The logs during the set time period are displayed.

8.10 Storage Management


8.10.1 Storage Mode

Allocate disks or RAID groups to different disk groups, and store video and image to specified disk group.

8.10.1.1 Setting Disk Group



Disk and created RAID group are allocated to group 1 by default. You can allocate disk and RAID group to other groups according to your actual needs.

The default number of disk group is the same as the maximum number of HDD that IVSS supports. For example, the Device supports a maximum number of 16 HDDs, and then the default number of disk group is 16.

Step 1 Click , or click  on the configuration interface, and then select **VIDEO RECORDING > Storage Mode > Disk Group**.

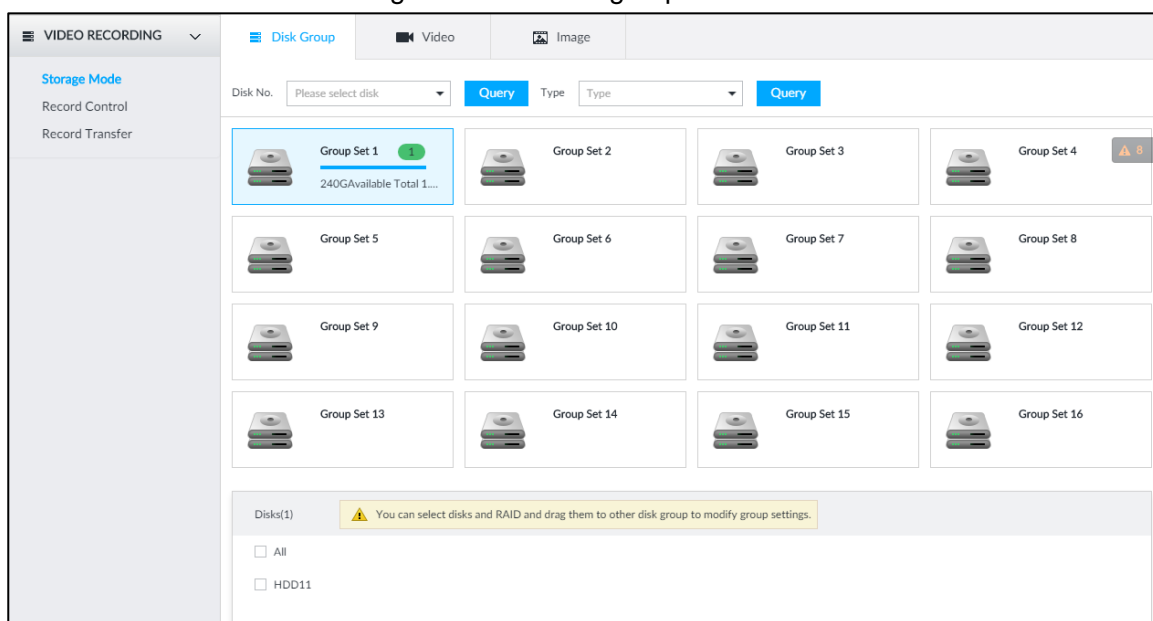
The **Disk Group** interface is displayed. See Figure 8-146.



- Select HDD or RAID group from , and then click **Query** to search the disk group of HDD or RAID group.
- The value (such as ) next to the group name refers to the number of HDD and RAID group in the disk group. If instead,  is displayed, it means no

available HDD or RAID group in the disk group, but there is video or image stored in the disk group.

Figure 8-146 Disk group



Step 2 Click a disk group.

The disk information of the group is displayed.

Step 3 Select HDD or RAID group from **Disks**, and then drag the HDD or the RAID group to another disk group.



Disk grouping takes effect immediately.



Select **All** to select all the HDDs and RAID groups of the disk group.

After configuring disk groups, you can also view which disk group the selected disk, video or picture belongs to. For details, see Table 8-42.

Table 8-42 Disk group functions

Function	Description
View the disk group of a disk, video or picture	Click  , select a disk or RAID group, and then click Query to search for the disk group that the selected disk or RAID group belongs to.
View disk groups of video or image	Select Video or Image from  , and then click Query to search for disk groups of the selected type.



8.10.1.2 Setting Video/Image Storage

Videos/images of all channels are stored in disk group 1 by default. You can store the videos/images in different disk groups according to actual needs. Two methods are available to set video/image storage.



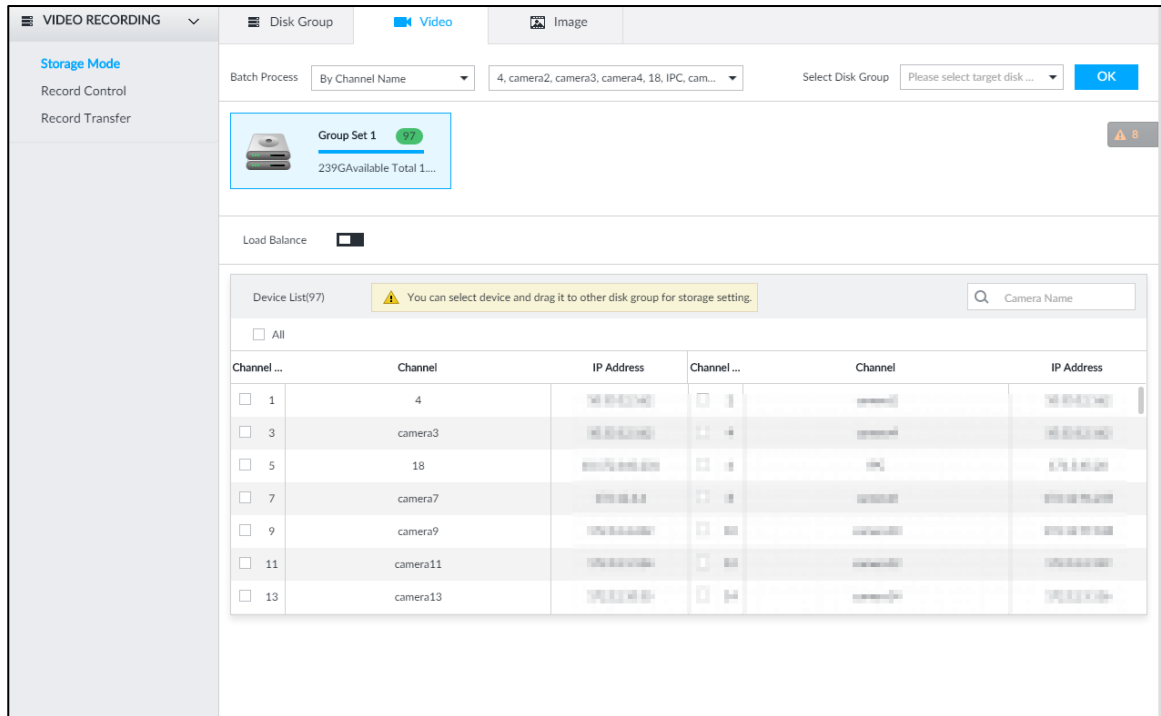
This section takes storing video for example. To store images, the procedure is similar.

Method 1

Step 1 Click , or click  on the configuration interface, and then select **VIDEO RECORDING > Storage Mode >Video**.

The **Video** interface is displayed. See Figure 8-147.

Figure 8-147 Video



Step 2 Select filtering way from the **Batch Process** drop-down list.

- **By Channel Name:** Select channel according to the channel name.
- **By Logical Channel No.:** Select channel that is connected to IVSS. In this case, **Start Channel No.** and **End Channel No.** need to be configured.

Step 3 In the **Select Disk Group** drop-down list, select target disk group.





In the drop-down list, only disk group with available HDD or RAID group is displayed.

Step 4 Click **OK**.

Disk grouping takes effect immediately.

Method 2

Step 1 Click , or click  on the configuration interface, and then select **VIDEO RECORDING > Storage Mode >Video**.

The **Video** interface is displayed. See Figure 8-147.

Step 2 Click a disk group.

The linked channels of the disk group are displayed in **Device List**. See Figure 8-148.

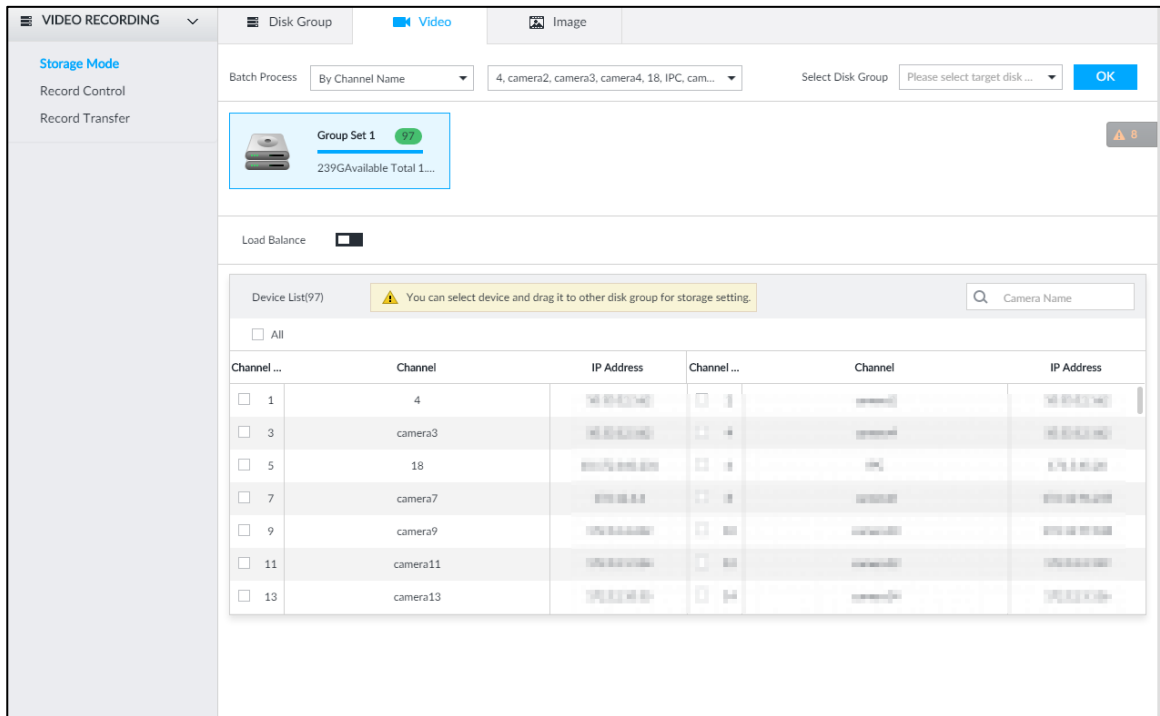


- Only disk group with available HDD or RAID group or linked channel is

displayed.

- The value (such as **1**) next to the group name refers to the number of HDD and RAID group in the disk group. If instead, **!** is displayed, it means no available HDD or RAID group in the disk group, but there is video or image stored in the disk group.

Figure 8-148 Device list





Step 3 (Optional) Click to enable load balance, and then the icon turns into blue. To disable it, click it again, and then the icon turns into gray.

- After load balance is enabled, if one disk group has no usable disk, the video of all channels that belong to this disk group will be stored into all the usable disk groups.
- When load balance is not enabled, if one disk group has no usable disk, the video of all channels that belong to this disk group will be stored in another usable disk group.

Step 4 Select a channel from the device list, and drag the channel to the target disk group. Disk grouping takes effect immediately.

8.10.2 Record Control

Configure recording schedules for channels.

Step 1 Click , or click  on the configuration interface, and then select **VIDEO RECORDING > Record Control**.

The **Record Control** interface is displayed. See Figure 8-149.

Figure 8-149 Record control

VIDEO RECORDING									
Storage Mode									
Record Control									
Record Transfer									
Channel No	Channel	<input checked="" type="checkbox"/> sto.MainStream	<input type="checkbox"/> Substream1	<input type="checkbox"/> Substream2	<input checked="" type="radio"/> Continuous	<input type="radio"/> Event	<input type="radio"/> Scheduled	<input type="radio"/> Schedule d&Event	<input type="checkbox"/> OFF
1	4	<input checked="" type="checkbox"/>	<input type="checkbox"/>	<input type="checkbox"/>	<input checked="" type="radio"/>	<input type="radio"/>	<input type="radio"/>	<input type="radio"/>	<input type="checkbox"/>
2	camera2	<input checked="" type="checkbox"/>	<input type="checkbox"/>	<input type="checkbox"/>	<input checked="" type="radio"/>	<input type="radio"/>	<input type="radio"/>	<input type="radio"/>	<input type="checkbox"/>
3	camera3	<input checked="" type="checkbox"/>	<input type="checkbox"/>	<input type="checkbox"/>	<input checked="" type="radio"/>	<input type="radio"/>	<input type="radio"/>	<input type="radio"/>	<input type="checkbox"/>
4	camera4	<input checked="" type="checkbox"/>	<input type="checkbox"/>	<input type="checkbox"/>	<input checked="" type="radio"/>	<input type="radio"/>	<input type="radio"/>	<input type="radio"/>	<input type="checkbox"/>
5	18	<input checked="" type="checkbox"/>	<input type="checkbox"/>	<input type="checkbox"/>	<input checked="" type="radio"/>	<input type="radio"/>	<input type="radio"/>	<input type="radio"/>	<input type="checkbox"/>
6	IPC	<input checked="" type="checkbox"/>	<input type="checkbox"/>	<input type="checkbox"/>	<input checked="" type="radio"/>	<input type="radio"/>	<input type="radio"/>	<input type="radio"/>	<input type="checkbox"/>
7	camera7	<input checked="" type="checkbox"/>	<input type="checkbox"/>	<input type="checkbox"/>	<input checked="" type="radio"/>	<input type="radio"/>	<input type="radio"/>	<input type="radio"/>	<input type="checkbox"/>
8	camera8	<input checked="" type="checkbox"/>	<input type="checkbox"/>	<input type="checkbox"/>	<input checked="" type="radio"/>	<input type="radio"/>	<input type="radio"/>	<input type="radio"/>	<input type="checkbox"/>
9	camera9	<input checked="" type="checkbox"/>	<input type="checkbox"/>	<input type="checkbox"/>	<input checked="" type="radio"/>	<input type="radio"/>	<input type="radio"/>	<input type="radio"/>	<input type="checkbox"/>
10	camera10	<input checked="" type="checkbox"/>	<input type="checkbox"/>	<input type="checkbox"/>	<input checked="" type="radio"/>	<input type="radio"/>	<input type="radio"/>	<input type="radio"/>	<input type="checkbox"/>
11	camera11	<input checked="" type="checkbox"/>	<input type="checkbox"/>	<input type="checkbox"/>	<input checked="" type="radio"/>	<input type="radio"/>	<input type="radio"/>	<input type="radio"/>	<input type="checkbox"/>
12	camera12	<input checked="" type="checkbox"/>	<input type="checkbox"/>	<input type="checkbox"/>	<input checked="" type="radio"/>	<input type="radio"/>	<input type="radio"/>	<input type="radio"/>	<input type="checkbox"/>
13	camera13	<input checked="" type="checkbox"/>	<input type="checkbox"/>	<input type="checkbox"/>	<input checked="" type="radio"/>	<input type="radio"/>	<input type="radio"/>	<input type="radio"/>	<input type="checkbox"/>
14	camera14	<input checked="" type="checkbox"/>	<input type="checkbox"/>	<input type="checkbox"/>	<input checked="" type="radio"/>	<input type="radio"/>	<input type="radio"/>	<input type="radio"/>	<input type="checkbox"/>
15	camera15	<input checked="" type="checkbox"/>	<input type="checkbox"/>	<input type="checkbox"/>	<input checked="" type="radio"/>	<input type="radio"/>	<input type="radio"/>	<input type="radio"/>	<input type="checkbox"/>

Step 2 Select one stream type.

- means that the type is selected.
- means that the type is not selected.

Step 3 Select a recording method.

Step 4 (Optional) click to disabled the recording schedule configuration of the selected channel



Step 5 Click **Save**.

8.10.3 Record Transfer

When the device and an IPC are disconnected, the IPC continues to record and stores the recording in the SD card. After the network is recovered, the device will download the recording during the disconnection from the IPC.

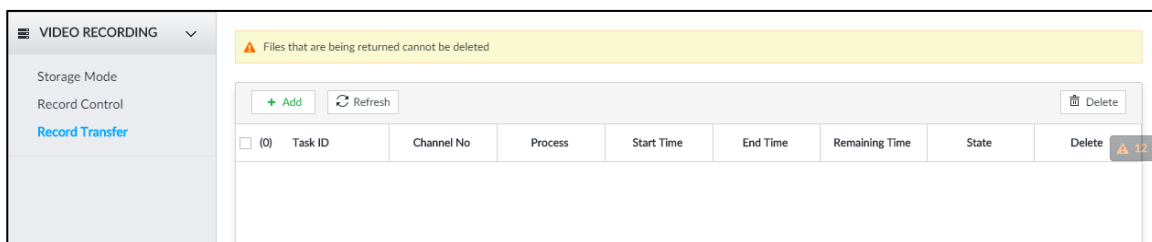
Two ways for record transfer after the network recovers.

- Automatic download: After the network recovers, the device automatically downloads the recording in the set time period, see "8.2.1.2 Configuring Storage Plans."
- Manual download: If ANR is not enabled when you set the storage plan, after the network recovers, the device can not automatically download the recording during the disconnection, the user can manually create the download task.

Step 1 Click , or click  on the configuration interface, and then select **VIDEO RECORDING > Record Transfer**.

The **Record Transfer** interface is displayed. See Figure 8-150.

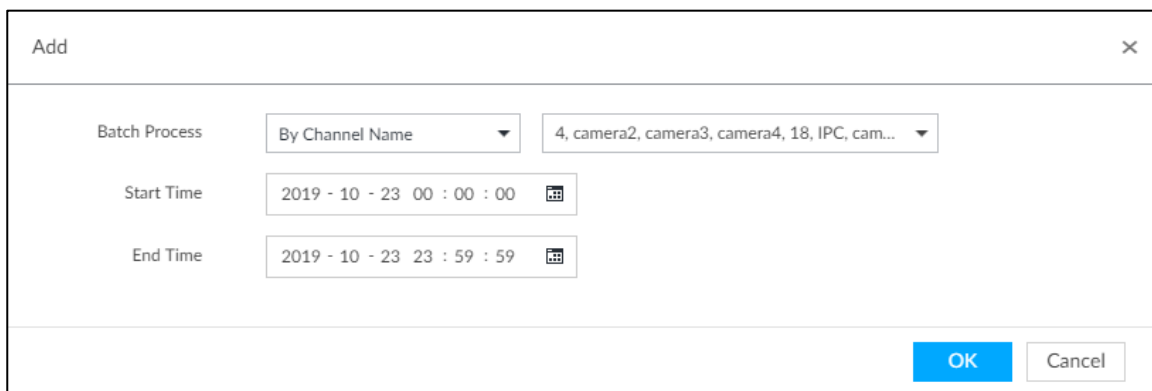
Figure 8-150 Record transfer



Step 2 Click **Add**.

The **Add** interface is displayed. See Figure 8-151.

Figure 8-151 Add



Step 3 Select **By Channel Name** or **By Channel No.** in the **Batch Process** drop-down list.

Step 4 Set time period of the video to be searched.

Step 5 Click **OK**.

The transfer progress is displayed.




Select a transfer task, click Delete to delete it. A task in progress cannot be deleted.

9 System Management

This chapter introduces system management operations including file management, maintenance, and task management.

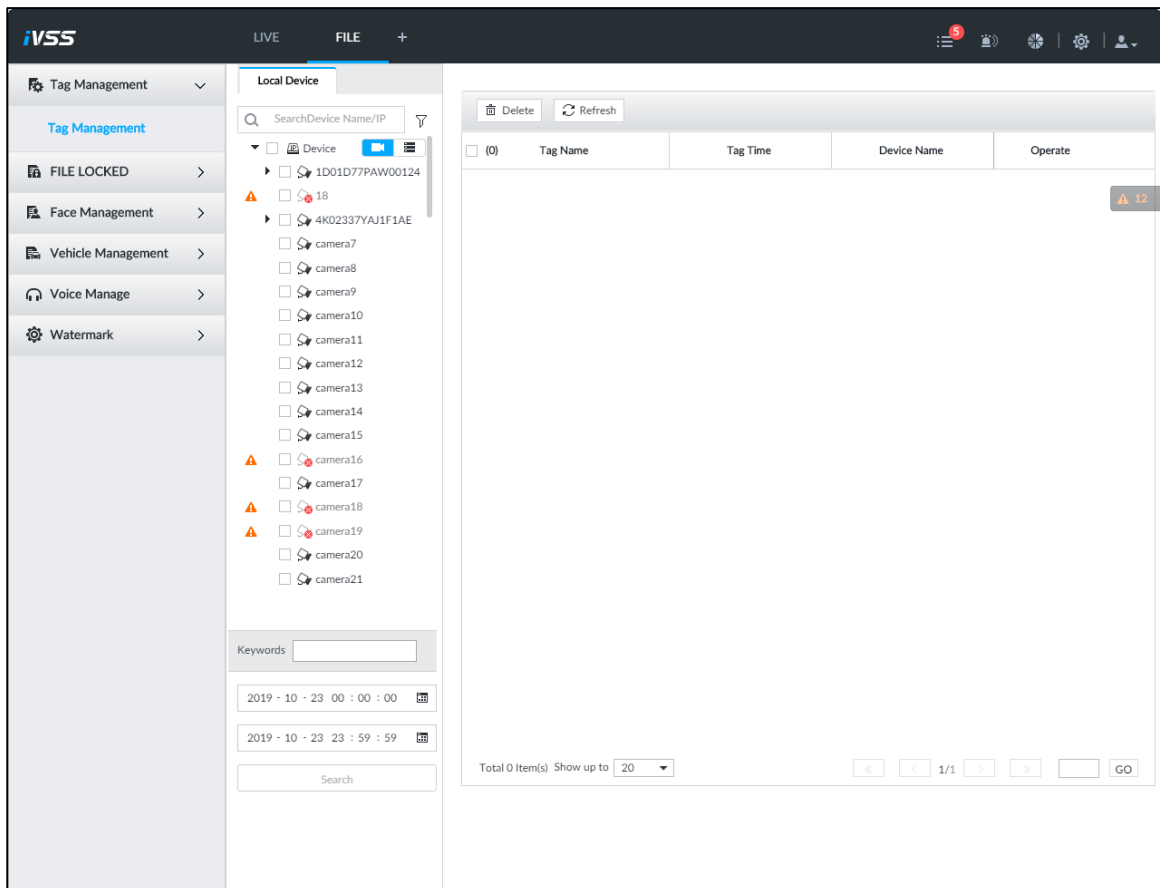
9.1 File Management

9.1.1 Video Tag Management

Step 1 On the **LIVE** interface, click , and then select **FILE > Tag Management > Tag Management**.




The **Tag Management** interface is displayed. See Figure 9-1.

Figure 9-1 Tag management




Step 2 Select a channel, set start time and end time, and then click **Search**.

The tags during the set time period are displayed.

- Click  to view the corresponding video.
- Click  to edit the tag.
- Click  to delete the tag.
- Select multiple tags and click **Delete** to delete the tags in batches.
- Click **Refresh** to video the latest tags.

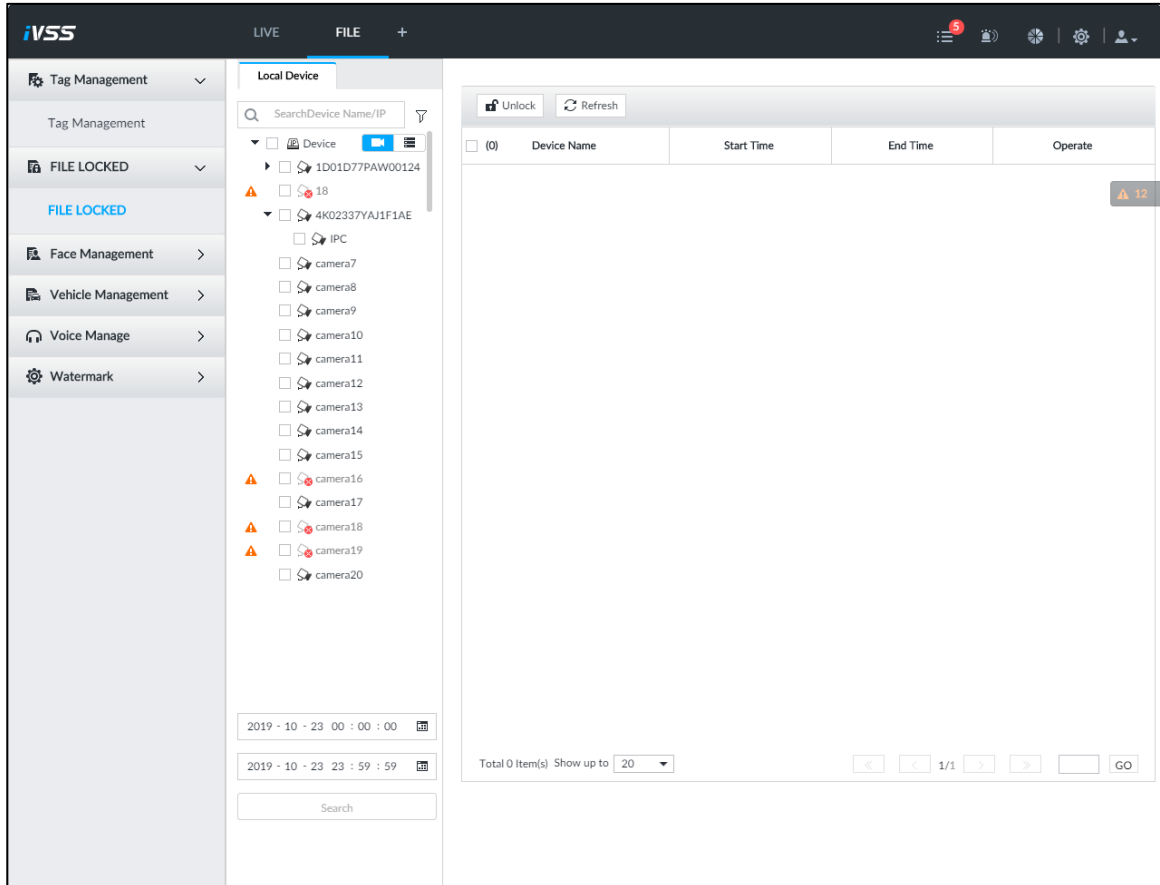
9.1.2 FILE LOCKED

View the locked video files, and you can unlock them.



Step 1 On the **LIVE** interface, click , and then select **FILE > FILE LOCKED > FILE LOCKED**.

The **FILE LOCKED** interface is displayed. See Figure 9-2.

Figure 9-2 FILE LOCKED interface



Step 2 Select a channel, set start time and end time, and then click **Search**.
The locked files are displayed.

- Click  to view the video of the locked file.
- Click **Refresh** to view the latest locked files.
- Click  to unlock a file.
- Select multiple files and click **Unlock** to unlock the files in batches.

9.1.3 Face Management

See "6.3.3 Configuring Face Database."

9.1.4 Vehicle Management

See "6.8.3 Configuring Vehicle Database."

9.1.5 Voice Management

Upload and manage audio files, so the device plays audios in case of events.

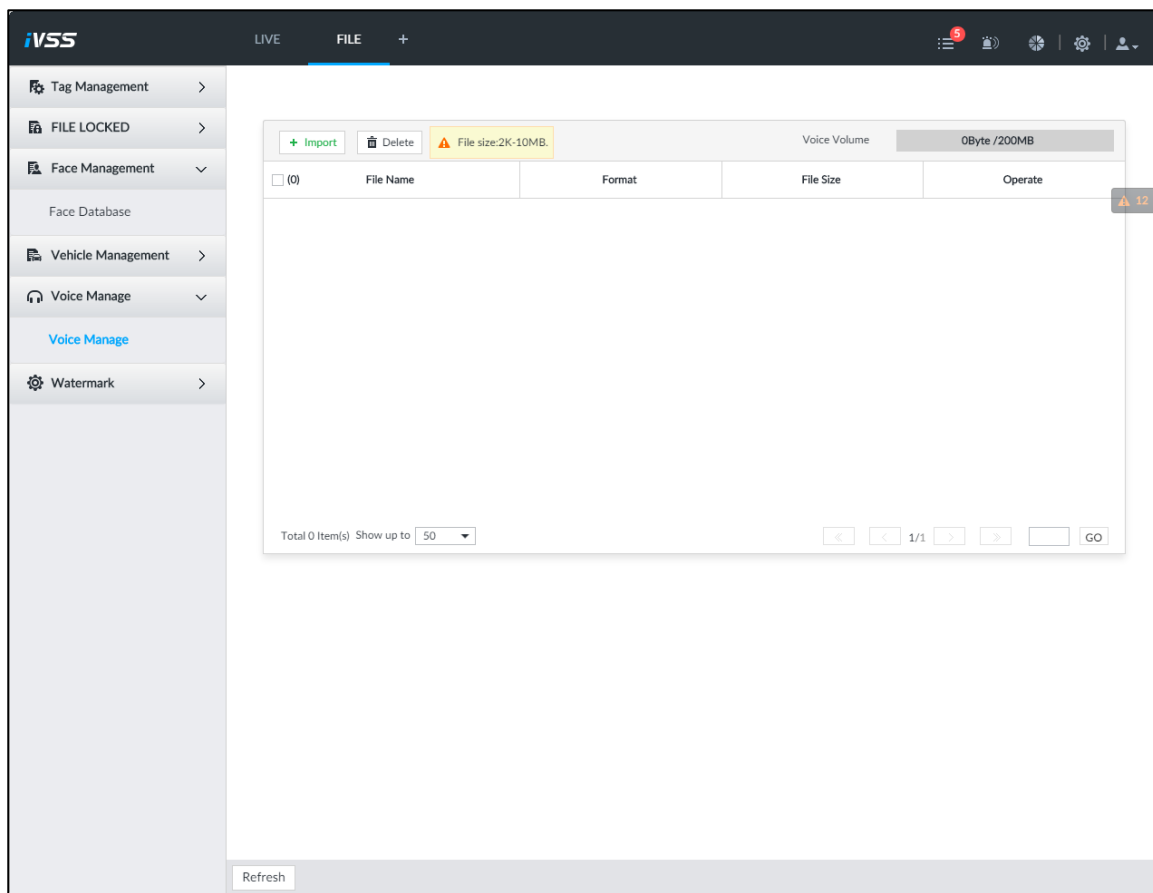


- You can upload .pcm, .mp3, .wav.,and .aac files.
- A single audio file shall not be less than 2KB and shall not exceed 10MB.
- Total size of imported audio files shall not exceed 200MB.

Step 1 On the **LIVE** interface, click **+**, and then select **FILE > Voice Manage > Voice Manage**.

The **Voice Manage** interface is displayed. See Figure 9-3.

Figure 9-3 Audio management

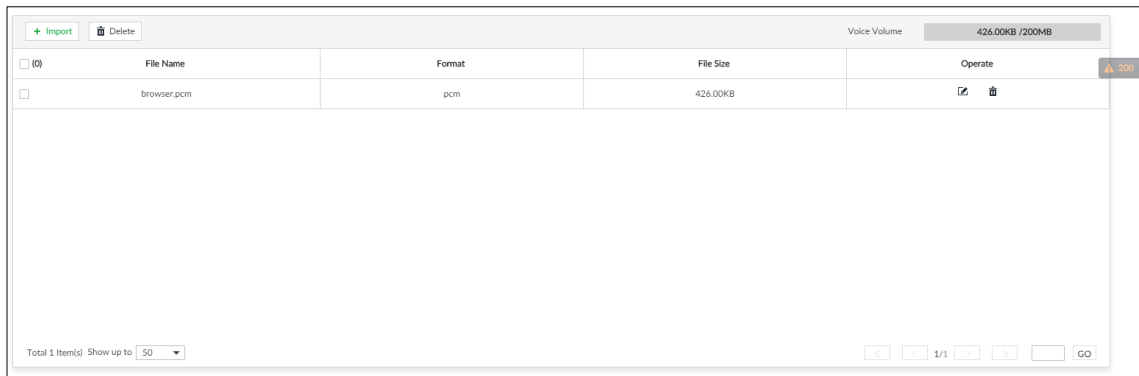


Step 2 Click **Import** to select the audio files that you want to import.

Step 3 Click **OK**.

The uploaded audio file is displayed. See Figure 9-4.

Figure 9-4 Audio file



After the audio file is uploaded, it can be renamed or deleted. For details, see Table 9-1.

Table 9-1 Audio file operation



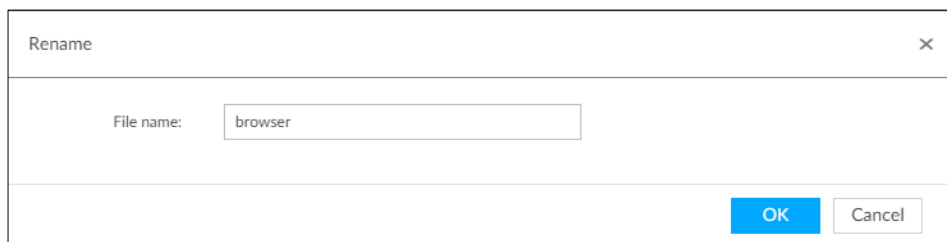

Name	Operation
Rename audio file	Click  beside the audio file. The Rename interface is displayed. See Figure 9-5. You can rename the audio file.
Delete audio file	<ul style="list-style-type: none"> • Delete: Click  beside the audio file. • Batch delete: Select multiple audio files, and click Delete.

Figure 9-5 Rename



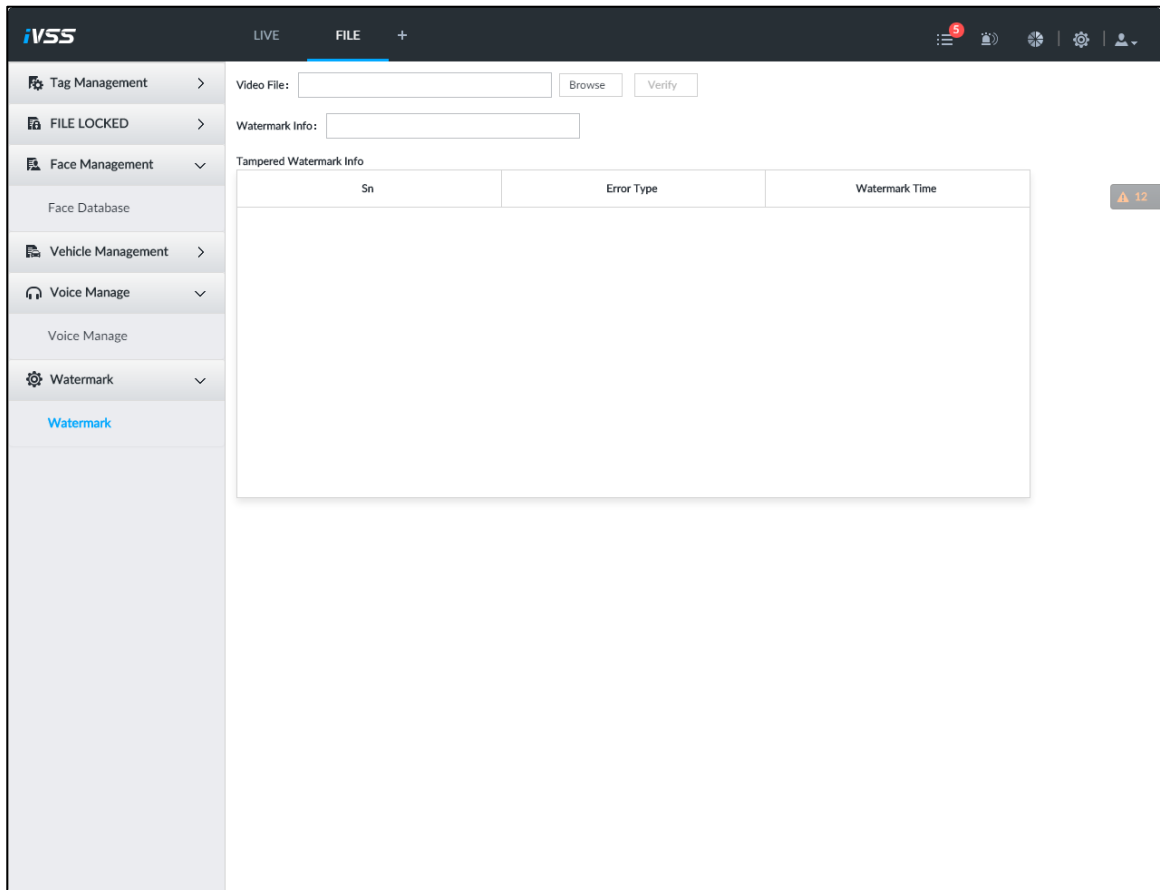
9.1.6 Watermark Verification

Verify whether a video file is tempered.

Step 1 On the **LIVE** interface, click , and then select **FILE > Watermark > Watermark**.

The **Watermark** interface is displayed. See Figure 9-6.

Figure 9-6 Watermark



Step 2 Click **Browse** to select a video file.

Step 3 Click **Verify**.

- Normal

If the verification result is normal, the correct watermark is displayed.

- Exception

If the verification result is abnormal, the abnormal watermark and its type are displayed.

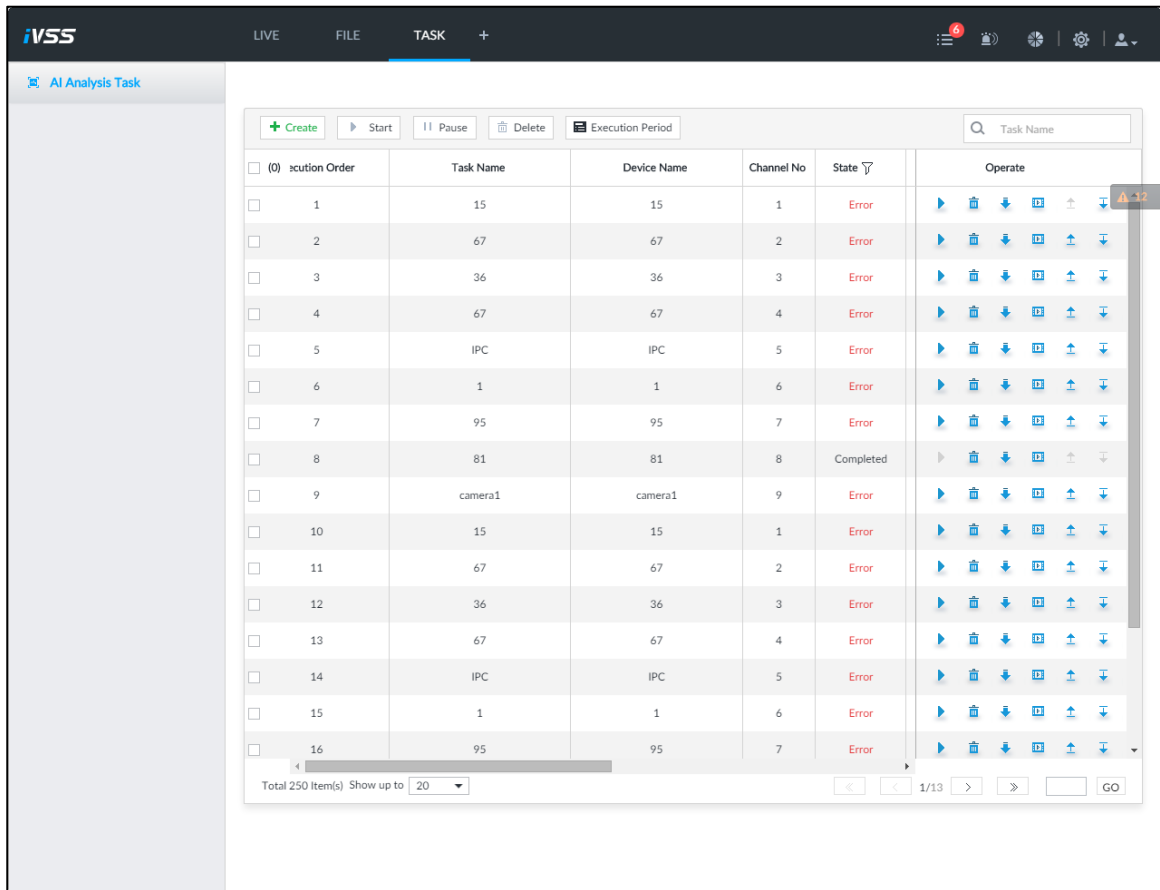
9.2 Task Management

Configure intelligent analysis tasks for metadata of recorded videos. After the intelligent analysis task is completed, you can view the metadata video on the playback interface. For details, see "6.2.4.2.3 Searching Task Lists."

Step 1 On the **LIVE** interface, click **+**, and then select **TASK**.

The **TASK** interface is displayed. See Figure 9-7.

Figure 9-7 Task management



Step 2 Click **Create**.

The **Create** interface is displayed. See Figure 9-8.




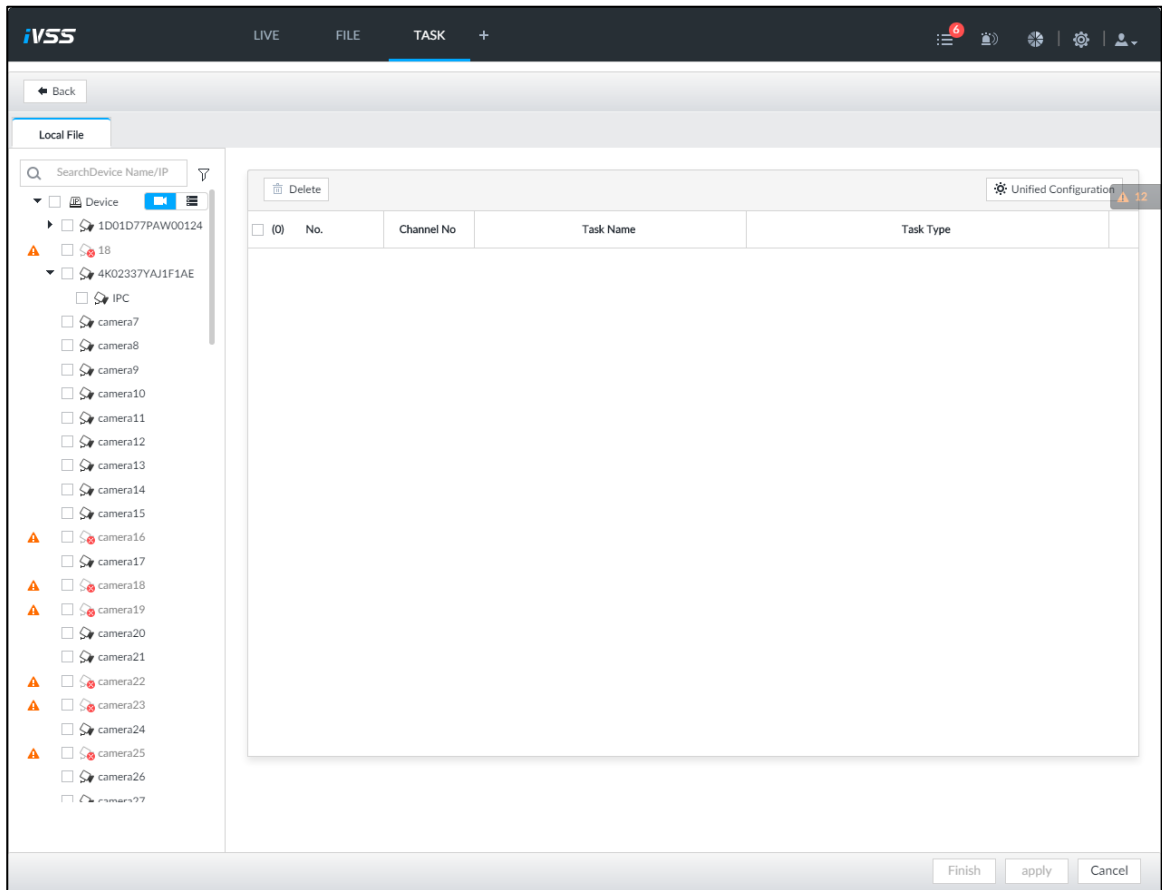
In the device tree,  indicates that the camera has been configured with intelligent analysis task.

Figure 9-8 Create a task

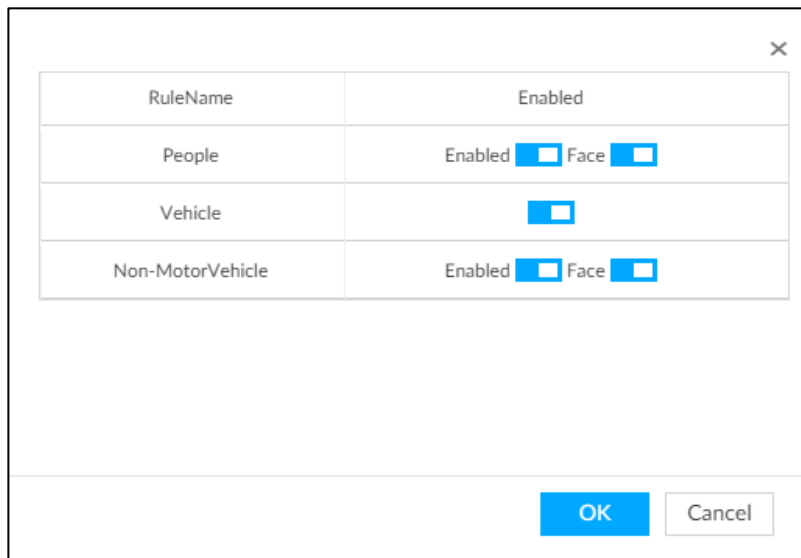


Step 3 Select a channel from the resource tree.

Step 4 Select a task type in the **Task Type** drop-down list.








- 1) Click the task type cell. The following dialogue box is displayed. See Figure 9-9.

Figure 9-9 Task type



- 2) Select a task type. For details, see Table 9-2.

Table 9-2 Task type description

Rule Name	Operations
People	<ul style="list-style-type: none"> Click  next to Enabled to enable human detection as well as face detection. Click  next to Face to disable face detection.  <p>You can only enable face detection after human detection has been enabled.</p>
Vehicle	Click  to enable vehicle detection.
Non-Motor Vehicle	<ul style="list-style-type: none"> Click  next to Enabled to enable non-motor vehicle detection as well as face detection. Click  next to Face to disable face detection.  <p>You can only enable face detection after non-motor vehicle detection has been enabled.</p>

3) Click **OK**.















Select multiple channels, click **Unified Configuration**, and then you can configure tasks in batches.

Step 5 Select start time and end time.

Step 6 Click **Apply**.

After creating the tasks, you can perform the following operations. See Table 9-3.

Table 9-3 Task operations

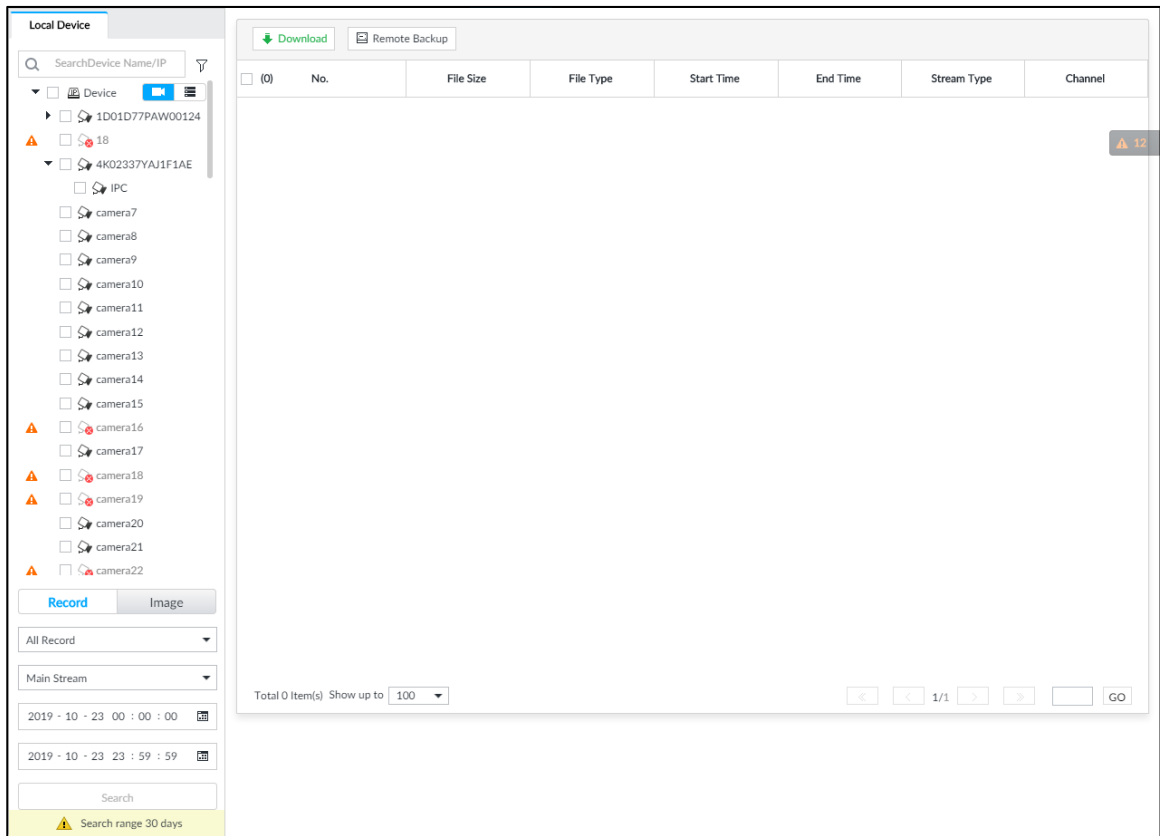
Function	Operation
	Click  to start a task.
	Click  to delete a task.
	Click  to download the task video.
	Click  to play back video of the task.
	Click  to increase the priority of the task.
	Click  to lower the priority of the task.
Start	Select tasks, and then click Start to start the tasks in batches.
Pause	Select tasks, and then click Pause to pause the tasks in batches.
Delete	Select tasks, and then click Delete to delete the tasks in batches.
Execution Period	Select one or more tasks, click Execution Period , and then select a time period. Tasks automatically run during this time period.

9.3 Backup

Step 1 On the **LIVE** interface, click , and then select **BACKUP**.

The **BACKUP** interface is displayed. See Figure 9-10.

Figure 9-10 Backup



Step 2 Select a channel from the resource tree on the left.

Step 3 Select a file type.

- Record
 - ◇ You can select record types including **All**, **Manual Record**, **Video Detect**, and **IO Alarm**.
 - ◇ You can select a stream type including **Main Stream** and **Sub Stream**.
 - ◇ Set the time period.
- Image
 - Select a snapshot type from **Manual Snap** and **Video Detect**.

Step 4 Click **Search**.

Step 5 Select a searched file, and then click **Remote Backup**.

The **Remote Backup** interface is displayed. See Figure 9-11.

Figure 9-11 Remote backup

Name	BUS Type	Free Space/Total	RemoteDirectory	Process
------	----------	------------------	-----------------	---------

Step 6 Click **Query** to search for connected third-party storage devices.

Step 7 Select a storage device, and then in the **Type** box, select a target format for the file.

Step 8 (Optional) Click **Format** to format the selected storage device. The formatting operation will clear all data of the storage device. Be cautious.

Step 9 Click **Start** to start backing up the file.

Step 10 (Optional) You can select a searched file, and then click **Download** to download it.


9.4 AI Report

On the **LIVE** interface, click , select **AI REPORT** and then you can view in-area people counting report and queue people counting report.



When viewing the report of a camera, make sure that people counting rules have been configured on it. For details, see "6.4 People Counting."

9.4.1 In-area People Counting Report

Step 1 On the **LIVE** interface, click , select **AI REPORT > AI REPORT > In Area People Counting Report**.

The **In Area People Counting Report** interface is displayed. See Figure 9-12.

Figure 9-12 In-area people counting report

Choose Device: 4(1D01D77PAW00124)

Statistics Type: People Counting

Strand Time: 5s 30s 60s

Time Period: Date: 2019 - 10 - 23

Step 2 Select a device to be searched. You can only select AI fisheye camera.

Step 3 Select a statistics type.

- People counting: Select **People Counting**, and then select the strand time (5 s, 30 s, 60 s).
- Average strand Time: The report shows the average strand time during different time periods.

Step 4 Select a time period type from **Daily**, **Monthly**, and **Yearly**, and then set the corresponding date, month or year.

Step 5 Click **OK**.

The report is displayed. See Figure 9-13 and Figure 9-14.

Figure 9-13 People counting report

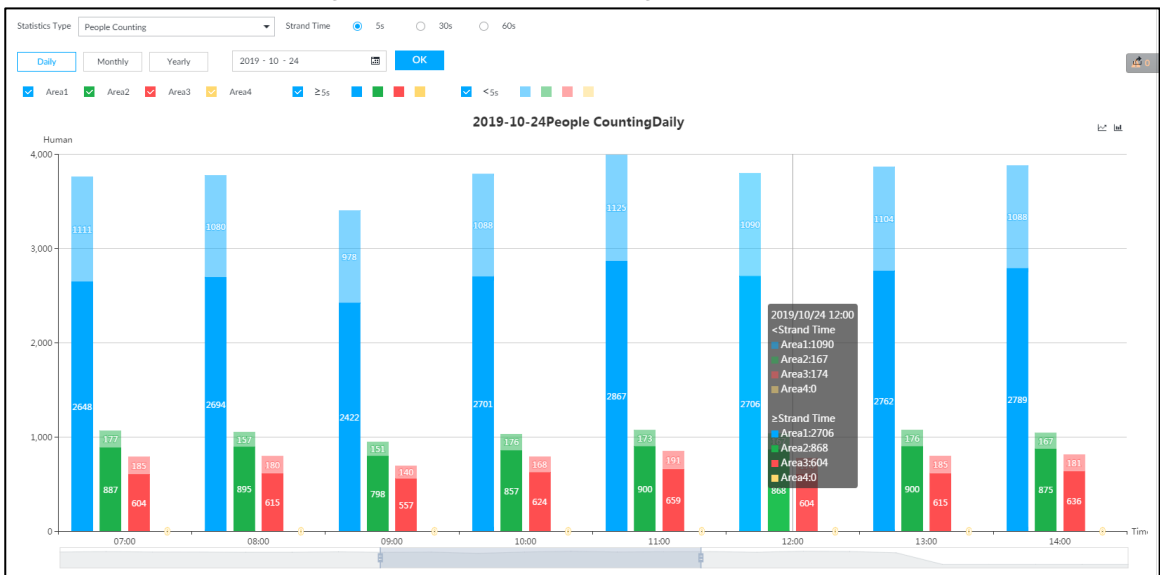
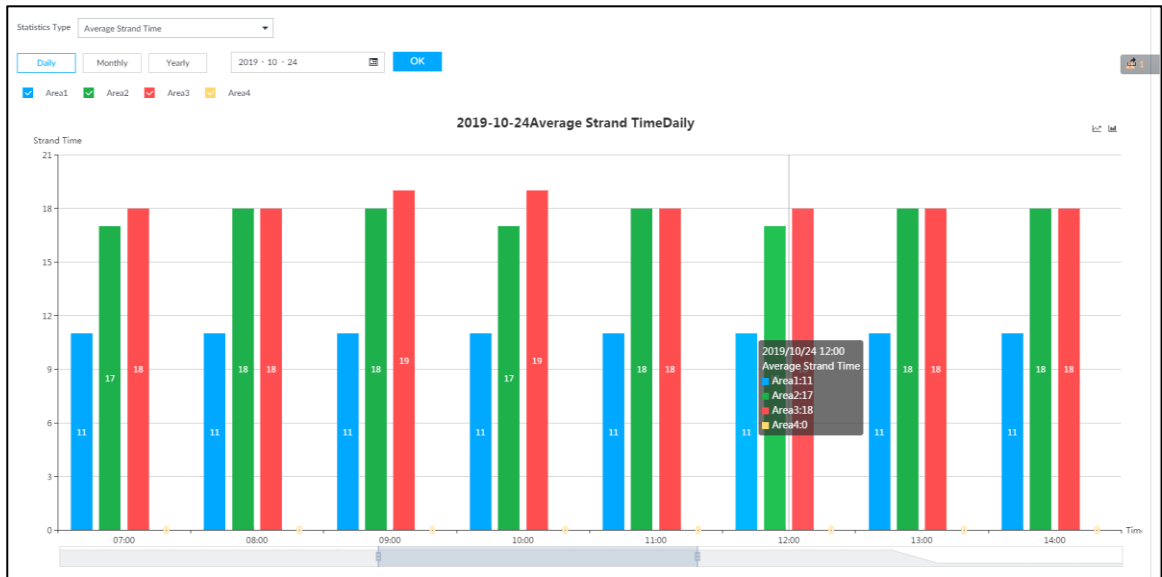


Figure 9-14 Average strand time report



- Click Area1 Area2 Area3 Area4 to select the areas of which you need to view the reports. The ordinate of the report displays different areas in different colors, showing the number of people in different areas or the average strand time.
- For people counting report, click Strand Time 5s 30s 60s to select a strand time. The report shows the people numbers of which the strand time is greater or less than the selected strand time.
- Point to the report, and then the report shows the details at that time point.
- Drag the gray scroll bar under the ordinate to view the statistics for different time periods.
- Click to view the line chart.
- Click to view the bar chart.
- Click to export the report.

9.4.2 Queue People Counting Report

Step 1 On the **LIVE** interface, click , and then select AI REPORT > AI REPORT> Queue People Counting.

The **Queue People Counting** interface is displayed. See Figure 9-15.

Figure 9-15 Queue people counting

Step 2 Select a device to be searched. You can only select AI fisheye camera.



Step 3 Select a queue time.

Step 4 Select a time period type from **Daily**, **Monthly**, and **Yearly**, and then set the corresponding date, month or year.

Step 5 Click **OK**. The report is displayed. See Figure 9-16.

Figure 9-16 Queuing people counting report



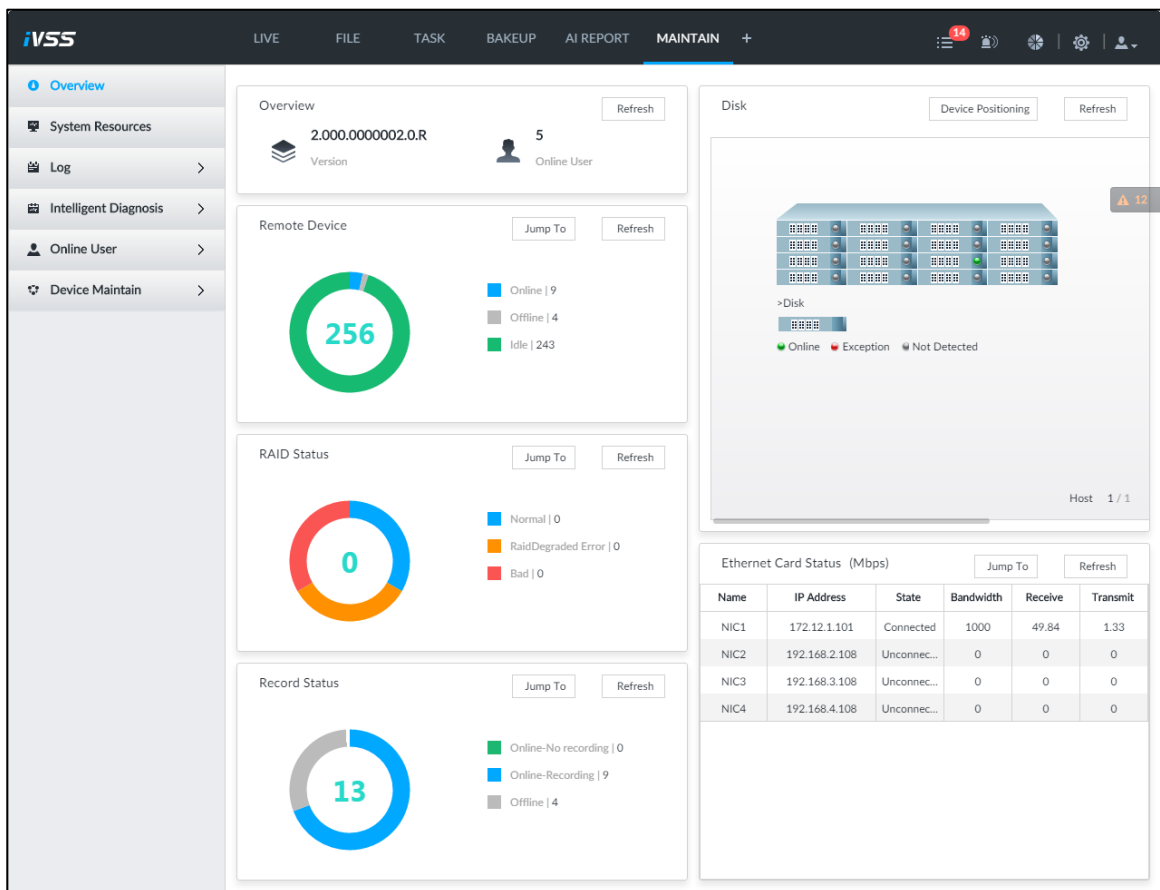
- The ordinate of the report displays different areas in different colors, showing the number of people in different areas or the average dwell time.
- Point to the report, and then the report shows the details at that time point.
- Drag the gray scroll bar under the ordinate to view the statistics for different time periods.
- Click  to view the line chart.
- Click  to view the bar chart.

10 System Maintenance

Click **+** on the **LIVE** interface, and select **MAINTAIN**. The **MAINTAIN** interface is displayed. See Figure 10-1.

You can operate and maintain the device working environment to guarantee proper operation.

Figure 10-1 Maintain



10.1 Overview

Click **+** on the **LIVE** interface, and select **MAINTAIN > Overview**.

The **Overview** interface is displayed. See Figure 10-2. For details, see Table 10-2.

Figure 10-2 Overview

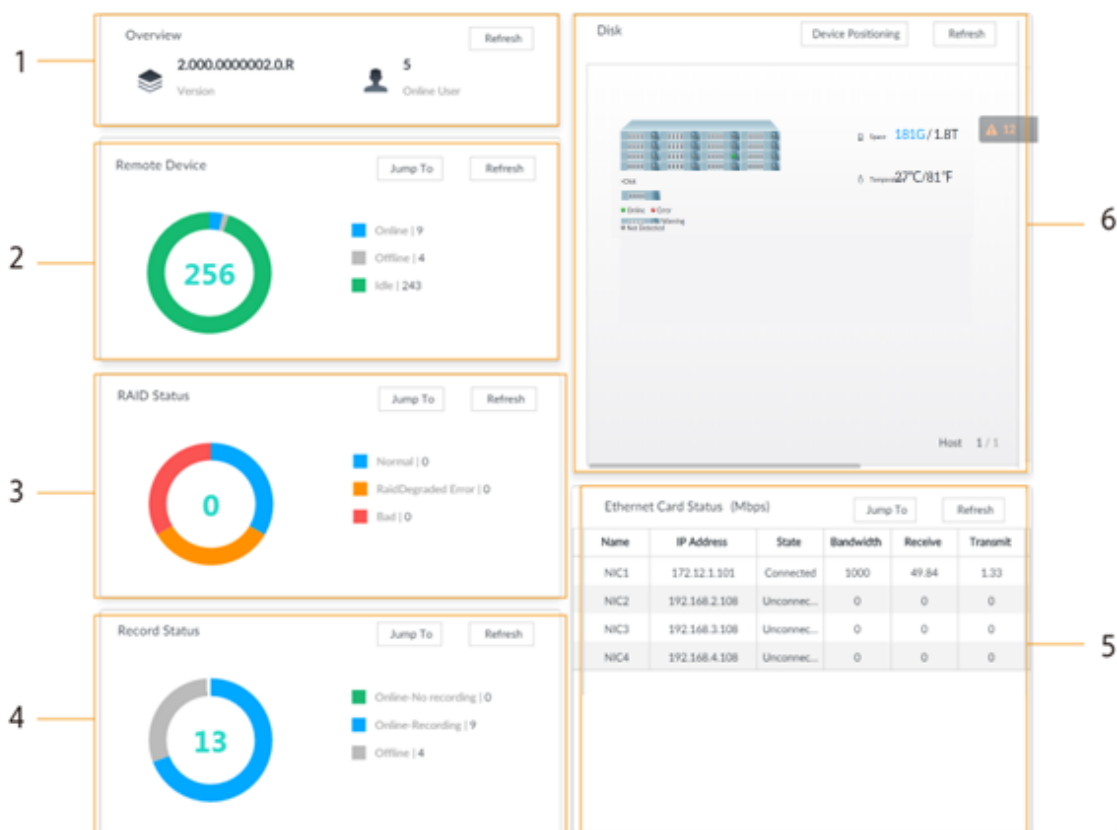





Table 10-1 Overview

No.	Function	Description
1	Overview	View device version details and online users. Click Refresh to refresh the data.
2	Remote Device	View the connection and idle status of remote devices <ul style="list-style-type: none"> Click Jump To to go to the DEVICE interface for detailed information. Click Refresh to refresh the data.
3	RAID Status	View RAID status. <ul style="list-style-type: none"> Click Jump To to go to the STORAGE interface for detailed information. Click Refresh to refresh the data.
4	Record Status	View recording status of remote devices. <ul style="list-style-type: none"> Click Jump To to go to the VIDEO RECORDING interface for detailed information. Click Refresh to refresh the data.
5	Ethernet Card Status (Mbps)	View NIC status. <ul style="list-style-type: none"> Click Jump To to go to the TCP/IP interface for detailed information. Click Refresh to refresh the data.
6	Disk	View disk status, device temperature and storage usage. <ul style="list-style-type: none"> ◇ ● indicates that the disk is online.



No.	Function	Description
		<ul style="list-style-type: none"> ◇  indicates that the disk is exception. ◇  indicates that the slot has no disk. ● Click Device Positioning, and then the device positioning indicator flashes. In this way, you can quickly find the device. ● Click Refresh to refresh the data.

10.2 System Resources


Click  on the **LIVE** interface, and select **MAINTAIN > System Resources**.

The **System Resources** interface is displayed. See Figure 10-3. You can view resource status including CPU and memory usage, panel temperature and fan speed.

Figure 10-3 System resources

Message Type: DEVICE INFO			
Detection Item	Type	Value	
Memory	Used Space/Total Space	12.02GB/15.51GB	 0
CPU	CPU Usage	4%	
CabinetFan1	Fan Speed	3540r/min	
CabinetFan2	Fan Speed	3540r/min	
Rear Panel1	Temperature	31°C	
Rear Panel2	Temperature	29°C	
Rear Panel3	Temperature	31°C	
Rear Panel4	Temperature	28°C	
CPU	Temperature	42°C	

Refresh

- Click  to filter the search conditions.
- Click **Refresh** to refresh the data.

10.3 Logs

The logs record all kinds of system running information. Check the log periodically and fix the problems in time to guarantee system proper operation.

Log Classification

Search system log, user log, event log, and link log. For details, see Table 10-2.

Table 10-2 Log description

Log	Type
System log	Search system log. It includes logs of system running status, file management, hot spare, hardware detect and scheduled task.
User operation log	Search user operation log. It includes user operation and user configuration log.
Event log	Search alarm event log. It includes logs of cross line detection, storage error, storage full, lock in, power fault, video motion, fan speed alarm, face detection, face recognition, human detect, device offline, tampering, no HDD, IPC offline, AI module offline, AI module temp, IO alarm, IP conflict, MAC conflict, and cross region detection.
Link log	Search device link log. You can search or export link log including user login/logout, session hijack, session blast and remote device.

Log Search

The following steps are to search system log. See the actual interface for detailed information.

Step 1 On the **LIVE** interface, click , and select **MAINTAIN > Log > System**.

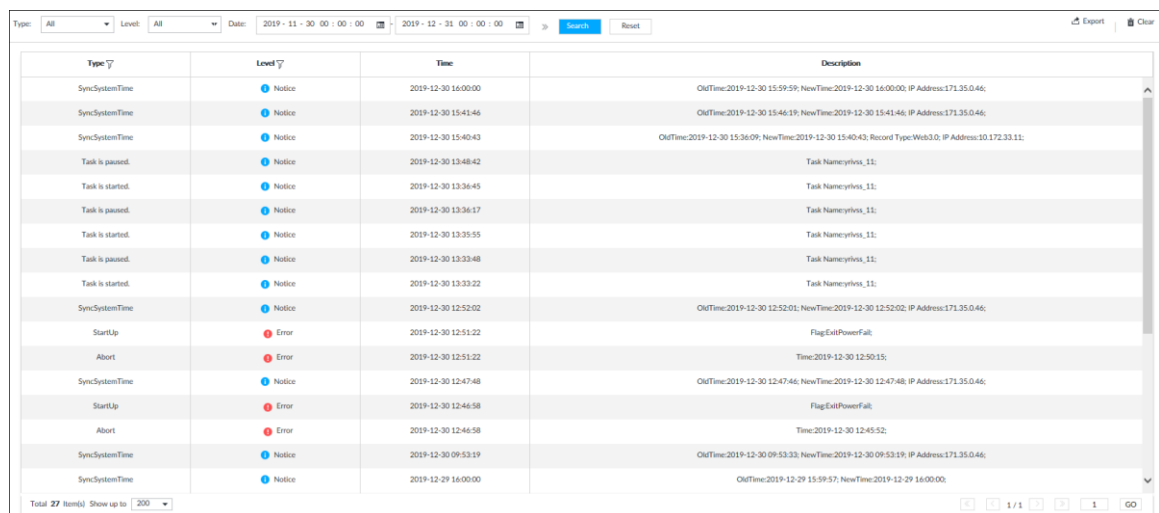
The **system** interface is displayed.

Step 2 Set search criteria such as system log level, type and date.

Step 3 Click **Search**.

The search results are displayed. See Figure 10-4.

Figure 10-4 System log





Type	Level	Time	Description
SyncSystemTime	Notice	2019-12-30 16:00:00	OldTime:2019-12-30 15:59:59; NewTime:2019-12-30 16:00:00; IP Address:171.35.0.46;
SyncSystemTime	Notice	2019-12-30 15:41:46	OldTime:2019-12-30 15:46:19; NewTime:2019-12-30 15:41:46; IP Address:171.35.0.46;
SyncSystemTime	Notice	2019-12-30 15:40:43	OldTime:2019-12-30 15:36:09; NewTime:2019-12-30 15:40:43; Record Type:Web3.0; IP Address:10.172.33.11;
Task is paused.	Notice	2019-12-30 13:48:42	Task Name:cylwst_11;
Task is started.	Notice	2019-12-30 13:36:45	Task Name:cylwst_11;
Task is paused.	Notice	2019-12-30 13:36:17	Task Name:cylwst_11;
Task is started.	Notice	2019-12-30 13:35:55	Task Name:cylwst_11;
Task is paused.	Notice	2019-12-30 13:33:48	Task Name:cylwst_11;
Task is started.	Notice	2019-12-30 13:33:22	Task Name:cylwst_11;
SyncSystemTime	Notice	2019-12-30 12:52:02	OldTime:2019-12-30 12:52:01; NewTime:2019-12-30 12:52:02; IP Address:171.35.0.46;
StartUp	Error	2019-12-30 12:51:22	FlagExitPowerFail;
Abort	Error	2019-12-30 12:51:22	Time:2019-12-30 12:50:15;
SyncSystemTime	Notice	2019-12-30 12:47:48	OldTime:2019-12-30 12:47:46; NewTime:2019-12-30 12:47:48; IP Address:171.35.0.46;
StartUp	Error	2019-12-30 12:46:58	FlagExitPowerFail;
Abort	Error	2019-12-30 12:46:58	Time:2019-12-30 12:45:52;
SyncSystemTime	Notice	2019-12-30 09:53:19	OldTime:2019-12-30 09:53:33; NewTime:2019-12-30 09:53:19; IP Address:171.35.0.46;
SyncSystemTime	Notice	2019-12-29 16:00:00	OldTime:2019-12-29 15:59:57; NewTime:2019-12-29 16:00:00;

Operation

Search, export and clear log. For details, see Table 10-3.

Table 10-3 Log operation

Name	Operation
Export log	Click  to export log information to local PC or USB storage device.
Clear log	 You will be unable to track the system error reason if you clear log. Click Clear all to clear all system logs.

10.4 Intelligent Diagnosis

10.4.1 Run Log

View system running logs for troubleshooting.



Make sure that you have enabled **Run Log** in **SECURITY > System Service**. Otherwise there is no log data.






On the **LIVE** interface, click , and select **MAINTAIN > Intelligent Diagnosis > Run Log**. The **SYSTEM** interface is displayed. See Figure 10-5.


Figure 10-5 Logs

<input type="checkbox"/> (0)	No.	Type	File Name	Operate
<input type="checkbox"/>	1	core	coredump/core-20191021142751@_JVSS2.000.0000002.0.R_172.12.1.101_123456789012345.gz	
<input type="checkbox"/>	2	core	coredump/core-20191021001805@_JVSS2.000.0000002.0.R_172.12.1.101_123456789012345.gz	
<input type="checkbox"/>	3	core	coredump/core-20191019220041@_JVSS2.000.0000002.0.R_172.12.1.101_123456789012345.gz	

- Click  to export a log.
- After selecting multiple logs, click **Export** to export them in batches.

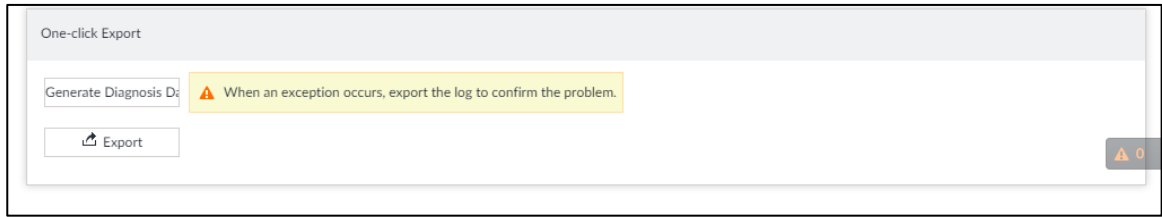
10.4.2 One-click Export

Export the diagnosis data for troubleshooting when the device is exception.

Step 1 On the **LIVE** interface, click , and select **MAINTAIN > Intelligent Diagnosis > One-click Export**.

The **One-click Export** interface is displayed. See Figure 10-6.

Figure 10-6 One-click export



Step 2 Click **Generate Diagnosis Data** to generate diagnosis data.


Step 3 Click **Export** to export the diagnosis result.

10.5 Online User

Search remote access network user information or you can block a user from access for a period of time. During the block period, the selected user cannot access the Device.



Cannot block yourself or block admin.


Step 1 On the **LIVE** interface, click , and select **MAINTAIN > Online User > Online User**.

The **Online User** interface is displayed. See Figure 10-7.



The list displays the connected user information.

Figure 10-7 Online user

<input type="checkbox"/>	User Name	Type	Login Time	IP	MAC	Link Type	Duration	Operate
<input type="checkbox"/>	admin	SDK	2018-11-20 17:00:29			TCP	79min	

Step 2 Block user.


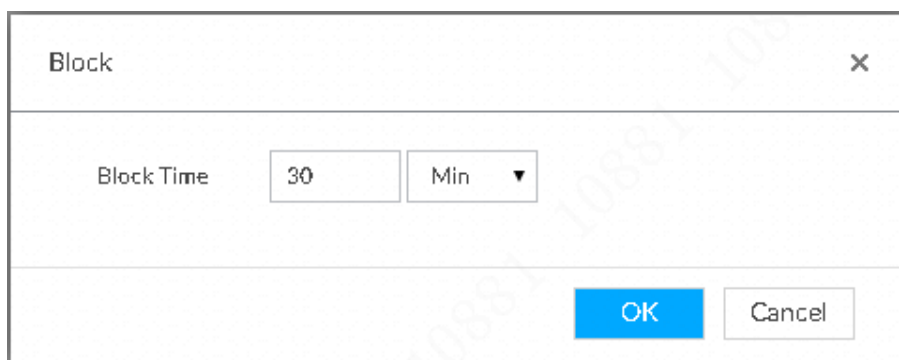
- Block: Click  corresponding to the user.
- Batch block: Select multiple users you want to block and then click **Block**. The **Block** interface is displayed. See Figure 10-8.

Figure 10-8 Block



The screenshot shows a dialog box titled "Block". Inside the dialog, there is a label "Block Time" followed by a text input field containing the number "30" and a dropdown menu with "Min" selected. At the bottom right of the dialog, there are two buttons: "OK" (highlighted in blue) and "Cancel".

Step 3 Set block period. The default period is 30 minutes.

Step 4 Click **OK** to save the configuration.

10.6 Device Maintenance

Device maintenance is to reboot device, restore factory default setup, or upgrade system and so on. Clear the malfunction or error during the system operation and enhance device running performance.

10.6.1 Upgrading Device

Upgrade device or the AI module version.

10.6.1.1 Upgrading the Device

You can import the upgrade file to upgrade device version. The upgrade file extension name shall be .bin.




- During upgrading, do not disconnect from power and network, and reboot or shut down the Device.
- Make sure that the upgrade file is correct. Improper upgrade file might result in device error!

Preparation

You need to obtain the correct upgrade file and save it in the corresponding path.

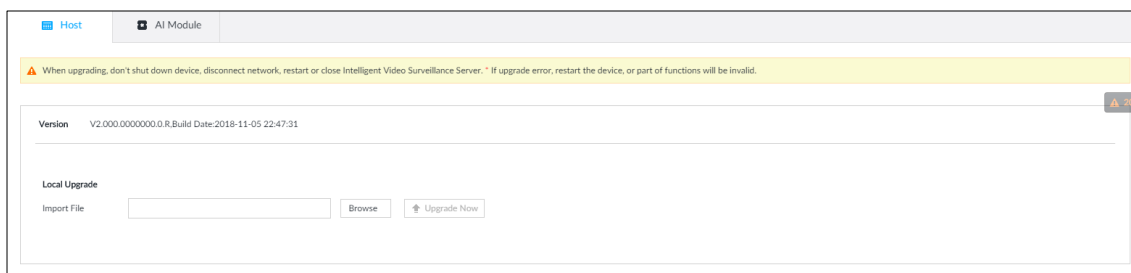
- When operating on the local interface, save the upgrade file in the USB storage device and then connect the USB storage device to the IVSS.
- When operating on the web or IVSS interface, save the upgrade file on the PC in which the Web or PCAPP is located.

Procedure

Step 1 On the **LIVE** interface, click , and select **MAINTAIN > Device Maintain > Upgrade > Host**.

The **Host** interface is displayed. See Figure 10-9.

Figure 10-9 Upgrade host

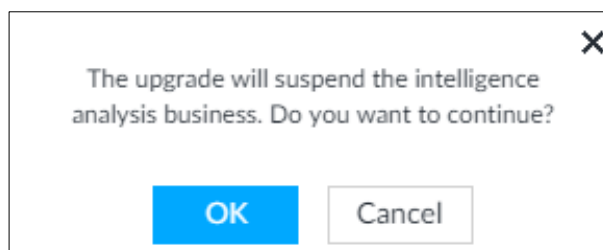


Step 2 Click **Browse** to select an upgrade file.

Step 3 Click **Upgrade Now**.

System pops up a confirmation box. See Figure 10-10.

Figure 10-10 Note



Step 4 Click **OK**.

The system starts upgrading. Device automatically reboots after successfully upgraded.


10.6.1.2 Upgrading Cameras

Import the upgrade file to upgrade a camera.



Make sure that you have got the upgrade file and placed it in the correct directory.

- During local operation, place the upgrade file in a USB storage device, and then connect the USB device to the device.
- If you use the web client or the PCAPP client, place the upgrade file in the computer you are using.

Step 1 On the **LIVE** interface, click , and select **MAINTAIN > Device Maintain > Upgrade > Camera Upgrade**.

The **Camera Upgrade** interface is displayed. See Figure 10-11.

Figure 10-11 Upgrade camera

File upgrade		Update max 8 remote devices each time.						
<input type="checkbox"/> (0)	No.	Device Name	IP Address	Port	Version	Upgrade St.	Type	Manufactur
<input type="checkbox"/>	1					--		Private
<input type="checkbox"/>	2					--	PSDW8...	Private
<input type="checkbox"/>	3	camera71		37777		--		Private
<input type="checkbox"/>	4	camera76		37777		--		Private
<input type="checkbox"/>	5	camera77		37777		--		Private
<input type="checkbox"/>	6	camera81		37777		--		Private
<input type="checkbox"/>	7	camera85		37777		--		Private
<input type="checkbox"/>	8	camera86		37777		--		Private
<input type="checkbox"/>	9	camera88		37777		--		Private
<input type="checkbox"/>	10	camera92		37777		--		Private
<input type="checkbox"/>	11	camera93		37777		--		Private
<input type="checkbox"/>	12	IPC		37777		--	IPC-HF8...	Private
<input type="checkbox"/>	13	IPC		37777		--	IPC-HF8...	Private

Total 15 Item(s) Show up to 20

Step 2 Select a camera, and then click **File upgrade**.

The **File upgrade** interface is displayed. See Figure 10-12.



Stop recording on the camera first; otherwise the upgrade might fail. If recording is not disabled, you will be prompted as follows. See Figure 10-13.

Figure 10-12 Upgrade

File upgrade ✕

⚠ When upgrading, don't shut down device, disconnect network, restart or close device.

Import File

Figure 10-13 Prompt

✕


Recording in progress. Please disable recording first, otherwise IPC update may fail. Continue?

Step 3 Click **Browse** to select an upgrade file.

Step 4 Click **Upgrade Now**.

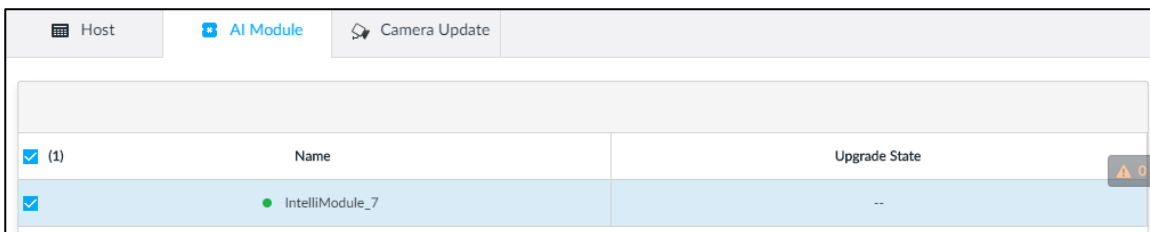
10.6.1.3 Viewing AI module

View the system version of the AI module installed on the device.



Step 1 On the **LIVE** interface, click , and then select **MAINTAIN > Device Maintain > Upgrade > AI Module**.

The **AI Module** interface is displayed. See Figure 10-14.

Figure 10-14 Upgrade AI module



Step 2 View AI module status.


-  indicates that the AI module is online.
-  indicates that the AI module is not started.
- Blank row indicates that the AI module is disconnected.

10.6.2 Default

When the system runs slowly and has configuration errors, try to solve the problems by restoring the default settings.

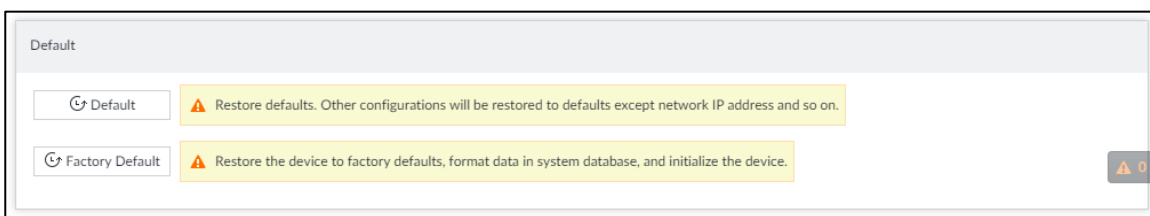


All configurations are lost after factory default operation.

Step 1 On the **LIVE** interface, click , and then select **MAINTAIN > Device Maintain > Default**.

The **Default** interface is displayed. See Figure 10-15.

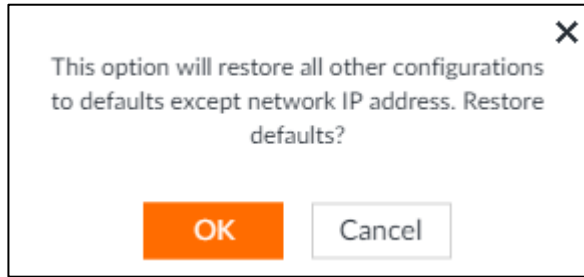
Figure 10-15 Default



Step 2 Select a method.

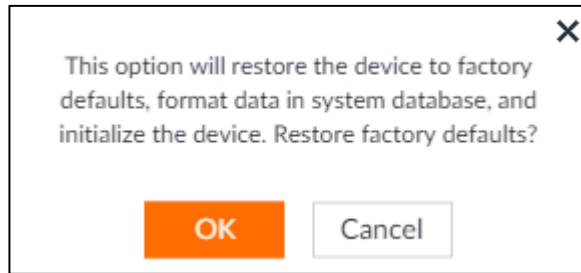
- Click **Default**.
The following prompt is displayed. See Figure 10-16.

Figure 10-16 Prompt (1)



- Click **Factory Default**.
The following prompt is displayed. See Figure 10-17.

Figure 10-17 Prompt (2)




Step 3 Click **OK**.

System begins to restore default settings. After successfully restored default settings, system prompts to restart the device.

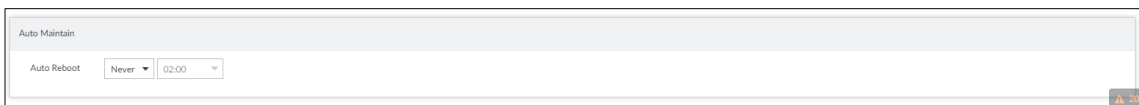
10.6.3 Automatic Maintenance

If the device has run for a long time, you can set to automatically reboot the device at idle time.

Step 1 On the **LIVE** interface, click , and then select **MAINTAIN > Device Maintain > Auto Maintain**.

The **Auto Maintain** interface is displayed. See Figure 10-18.

Figure 10-18 Auto Maintain



Step 2 Set auto reboot time.

Step 3 Click **Save**.

10.6.4 IMP/EXP

Export device configuration file to local PC or USB storage device, to backup it. When the configuration is lost due to abnormal operation, import the backup configuration file to restore system configurations quickly.


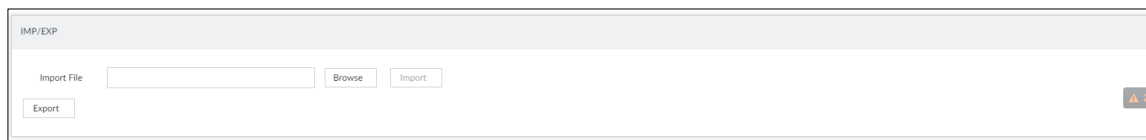

On the **LIVE** interface, click , and then select **MAINTAIN > Device Maintain > IMP/EXP**.
The **IMP/EXP** interface is displayed. See Figure 10-19.

Figure 10-19 IMP/EXP



Export Configuration File

Click **Export** to export configuration file to local PC or USB storage device. File path might vary depending on interface operations, and the actual interface shall prevail.

- On PCAPP, click , and then select **Download content** to view file saving path. For details, see "11.3 Viewing Downloads."
- Select file saving path during local operation.



Connect USB device to the system if you are on the local menu to operate.

- During web operations, files are saved under default downloading path of the browser.

Import Configuration File

Step 1 Click **Browse** to select the configuration file.

Step 2 Click Import.

After the configuration file is imported successfully, the device will reboot automatically.

11 PCAPP Introduction

After installing PCAPP, system supports to access the Device remotely to carry out system configuration, function operations and system maintenance.



For details about installing PCAPP, see "5.3.1 Logging in to PCAPP Client."

11.1 Interface Description



Double-click  on the PC desktop. System displays PCAPP at full screen by default. Click  to display the task column. See Figure 11-1. See Table 11-1 for detailed information.

Figure 11-1 IVSS task column

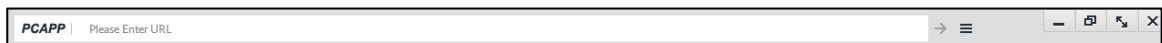
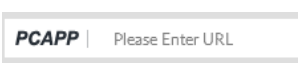











Table 11-1 Icons

Icons	Description
	Address bar: Enter the IP address of remote device.
	Enter device IP address and then click the button to go to the login interface.
	Now the icon turns into  . Click to refresh the interface.
	Click to view history login record, view downloads, set compatibility mode and view IVSS version information.
	Click to minimize PCAPP.
	Click to maximize PCAPP.
	Click to display PCAPP at full screen.
	Click to close PCAPP.

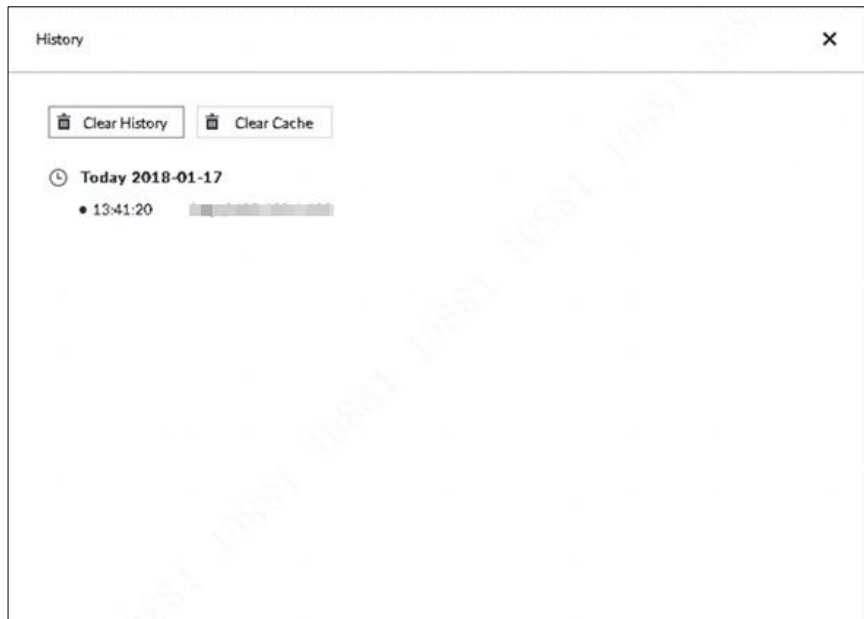
11.2 History Record

Click , and then select **History**.


The **History** interface is displayed. See Figure 11-2. You can view history access record and clear buffer.

- Click **Clear History** to clear all history records.
- Click **Clear Buffer** to clear buffer data, and reboot PCAPP.

Figure 11-2 History record



11.3 Viewing Downloads

To view and clear history downloads, click , and then select **Downloads**. The **Downloads** interface is displayed. See Figure 11-3.

- Double-click file name to open it.
- Click **Displayed in Folder** to open the folder where the file is located.
- Click **Clear Downloads** to clear history download records.

Figure 11-3 Downloads



11.4 Configuring PCAPP

When PC theme is not Aero, video of PCAPP might not be displayed normally. It is suggested that PC theme should be switched to Aero, or compatibility mode of PCAPP should be enabled.

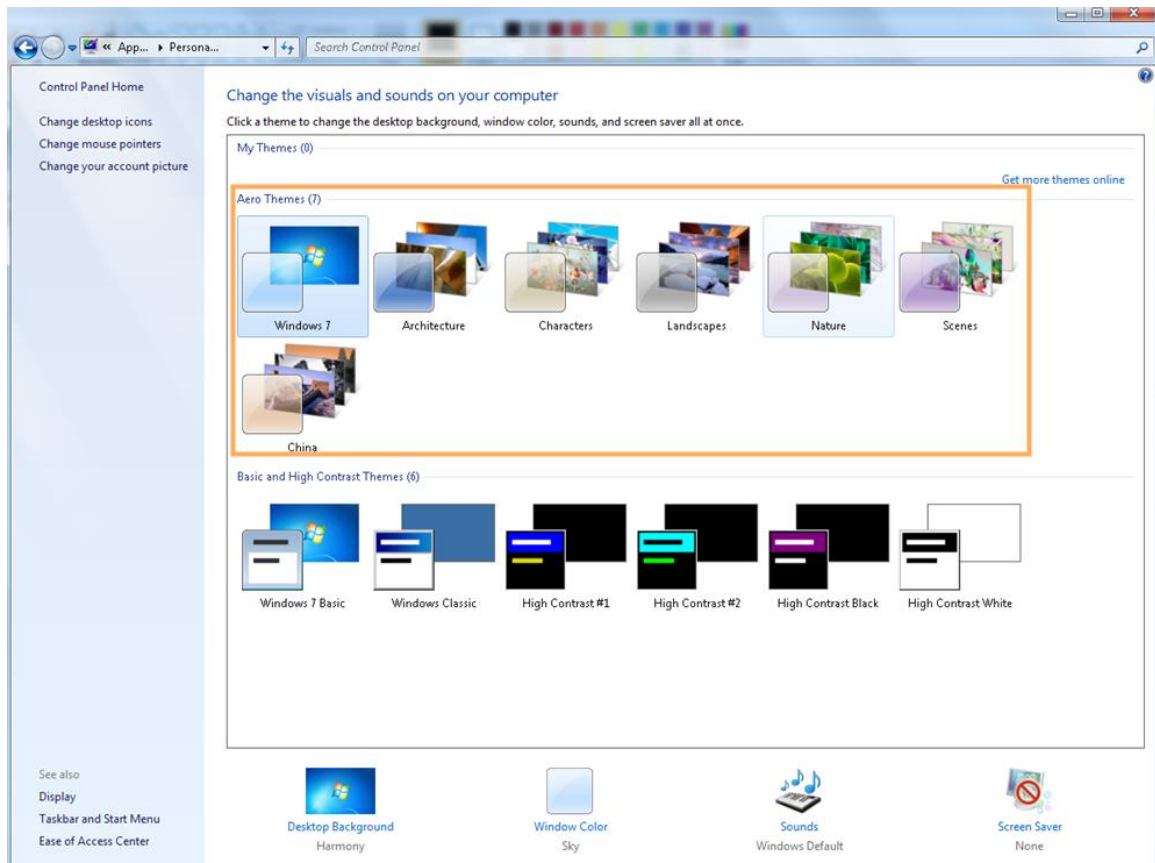
Switching PC Theme



This section takes Windows 7 as an example.

Right-click any blank position on PC desktop, select **Personalize**, and then switch to Aero theme. See Figure 11-4. Restart the PCAPP before the Aero theme takes effect.

Figure 11-4 PC theme



Enable Compatibility Mode


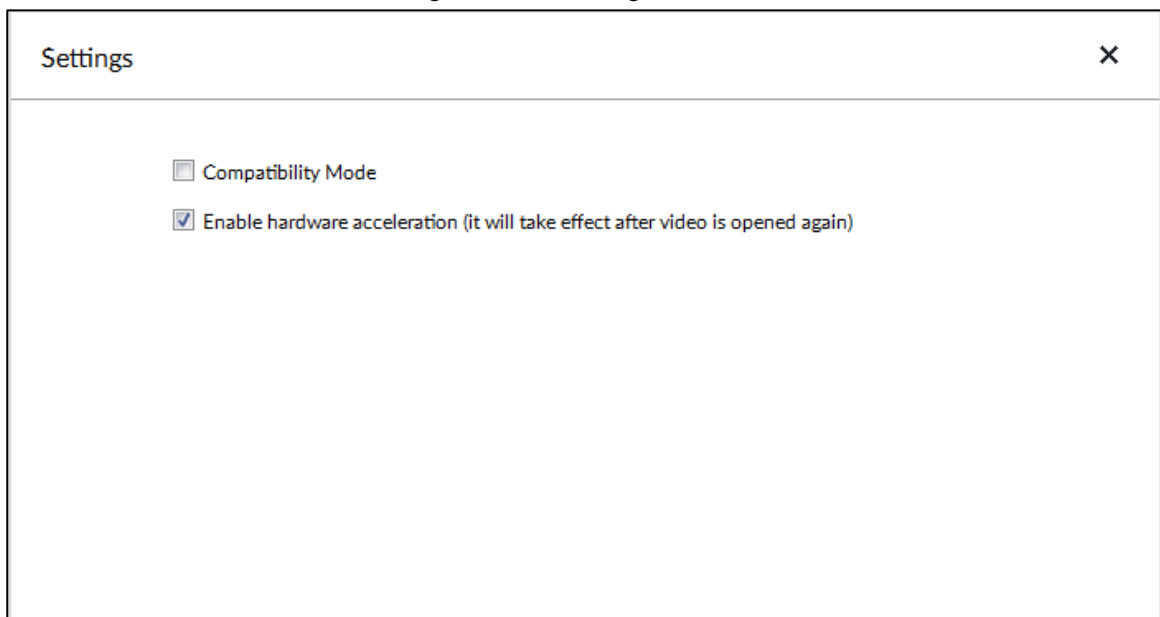

Click , and select **Settings**. The **Settings** interface is displayed. See Figure 11-5. Select **compatibility mode**. Restart PCAPP before the compatibility mode takes effect.

Figure 11-5 Setting



Enable Hardware Acceleration

Click , and select **Settings**. The **Settings** interface is displayed. See Figure 11-5. Select **Enable hardware acceleration (it will take effect after video is opened again)**.

The live view becomes much more fluent when this function is enabled.

11.5 Viewing Version Details


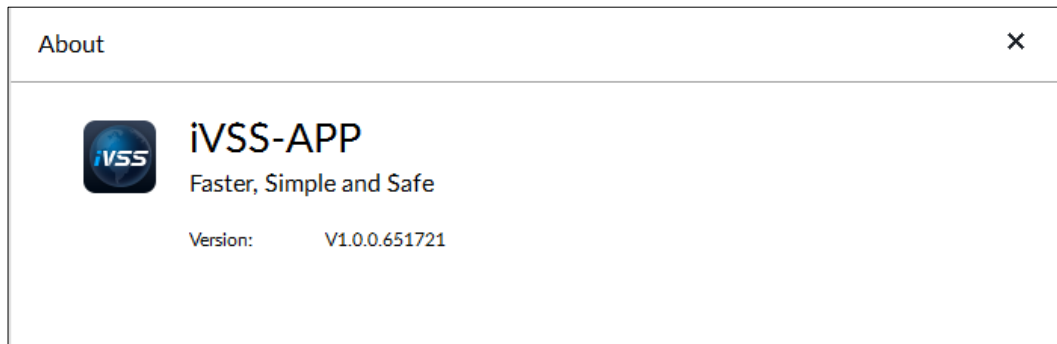
Click , and then select **About**. The **About** interface is displayed. See Figure 11-6. It is to view PCAPP version information.

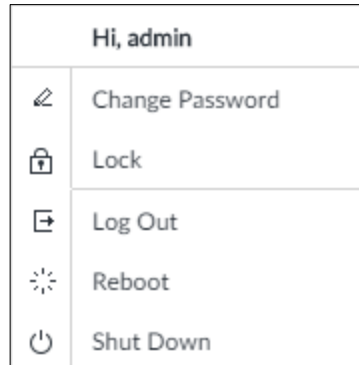
Figure 11-6 About




12 Log Out, Reboot, Shut Down, Lock

Log out, reboot, shut down and lock out the Device. See Figure 12-1.


Figure 12-1 User operation



Log Out

Click , and then select **Log Out**.


Reboot

Click , and then select **Reboot**. System pops up confirm dialogue box. Click **OK** to reboot.


Shut Down



To unplug the power cable might result in data (record and image) loss.

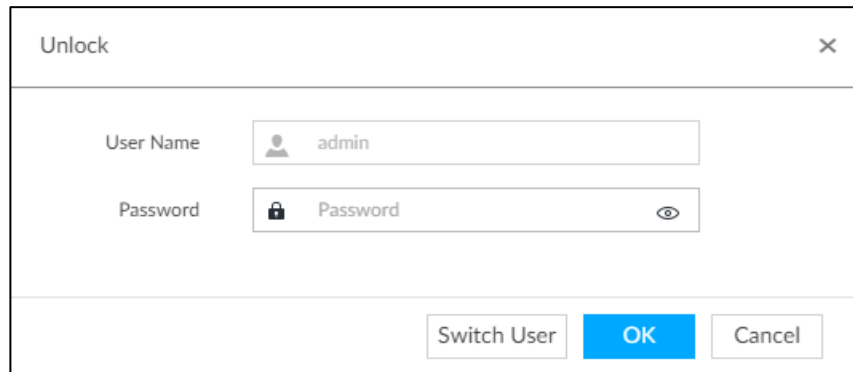
- Mode 1 (recommended): Click , and then select **Shutdown**. System pops up confirm dialogue box and then click **OK** to shut down.
- Mode 2: Use power on-off button on the device.
 - ◇ 8-HDD series product: Press power on-off button on rear panel.
 - ◇ Other series products: Press the power on-off button on the device for at least 4 seconds.
- Mode 3: Unplug the power cable.

Lock

Click , and then select **Lock** to lock the client. The locked client cannot be operated.


To unlock the client, click anywhere on the client, and then the **Unlock** dialogue box is displayed. See Figure 12-2. Enter the username and password, and then click **OK**. You can also click **Switch User** to switch to another user account.

Figure 12-2 Unlock the client



The image shows a standard Windows-style dialog box titled "Unlock". It features a close button (X) in the top right corner. The main area contains two input fields. The first is labeled "User Name" and contains the text "admin" next to a small person icon. The second is labeled "Password" and contains the text "Password" next to a lock icon and an eye icon. At the bottom of the dialog, there are three buttons: "Switch User", "OK" (which is highlighted in blue), and "Cancel".

13 FAQ

Problem	Possibilities and Solutions
<p>After enabling AI by device function, there is no human face recognition event.</p>	<ul style="list-style-type: none"> ● The AI module is offline. <p>On the LIVE interface, click . Select SYSTEM > MAINTAIN > Upgrade > AI Module, and then check the AI module is online or not.</p> <ul style="list-style-type: none"> ● There are too many filter criteria on the AI display interface. ● The registered remote device does not support face detection function. <p>Enable AI by device function. See "6.2.2 Configuring Face Detection" for detailed information.</p> <ul style="list-style-type: none"> ● It is not in the deployment period. ● There is no linked face database or the face database has no data. ● The human face similarity setting is too high.
<p>After enabling AI by camera function, there is no human face recognition event.</p>	<ul style="list-style-type: none"> ● The human face recognition function has not been enabled on the AI plan. ● There is no human face database on the web interface of the remote device. ● It is not in the deployment period.
<p>There are no human face search results.</p>	<ul style="list-style-type: none"> ● The human face similarity setting is too high. ● The selected remote device does not trigger the human face recognition. ● There is no human face recognition on the search period ● The specified human face image is not on the human face database.

Appendix 1 Mouse and Keyboard Operations

Appendix 1.1 Mouse Operations

Connect mouse to the USB port, you can use the mouse to control the local menu. For details, see the following table.

Operation	Description
Click (click the left mouse button)	<p>Click to select a function menu, to enter the corresponding menu interface.</p> <ul style="list-style-type: none">● Implement the operation indicated on the control.● Change check box and option button status.● Click the check box to display drop-down list.● On virtual keyboard, select letter, symbol, English upper letter and lower letter, and Chinese characters.
Double-click (click the left mouse button twice)	<ul style="list-style-type: none">● On the LIVE interface, double-click one video window to zoom in the window. Click any position out of the window, so the video window restores original size.● On the LIVE interface, double-click the remote device in the device tree. Switch to video edit status, and add remote device.● Double-click the image or record file thumbnail, to playback record file or view the image.
Right-click (click the right mouse button)	<ul style="list-style-type: none">● On the LIVE or SEARCH interface, right-click one video window to display the shortcut menu.● On the LIVE interface, right-click the view in the list or the remote device in the device tree, to display the shortcut menu.
Wheel button	<ul style="list-style-type: none">● On SEARCH interface, move the mouse pointer to the time bar, and then click the mouse wheel, to adjust the accurate time on the time bar.● Click the control that needs to enter number (such as date or time). Roll the mouse wheel to adjust the number value.
Drag the mouse	<ul style="list-style-type: none">● Drag the mouse pointer to select the motion detect zone.● On the LIVE interface, drag the remote device in the device tree to the play window, switch to the view status. It is to add the remote device.● On SEARCH interface, drag the record file or the image thumbnail to the playback window. It is to play back the corresponding record file or image.

Appendix 1.2 Virtual Keyboard

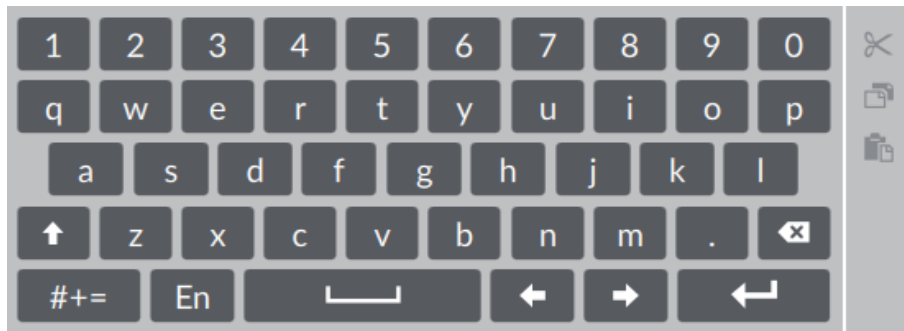
The local menu supports virtual keyboard.

Click the text box to display virtual keyboard interface. For details, see the following pictures and table.



If the device has connected to the peripheral keyboard, click the text column. Virtual keyboard will disappear.














Virtual keyboard (global keyboard)



Virtual keyboard (digital keyboard)



Virtual keyboard icon

Signal Words	Description
	Click the icon to switch to upper case. The icon becomes  . Click  to switch to lower case.
	Click to delete letter.
	Click to enter letter. Now the icon turns into  . Click  to restore previous input mode.
	Click to input space.
	Click to control cursor position.
	Click to switch to the next line.
	Select text and click the icon to cut the selected contents.
	Select text and click the icon to copy the selected contents.
	Cut or copy the contents, click the text box and click the icon to paste the contents.

Virtual keyboard (input letter)



Appendix 2 RAID

RAID is an abbreviation for Redundant Array of Independent Disks. It is to combine several independent HDDs (physical HDD) to form a HDD group (logic HDD).

Comparing with one HDD, RAID provides more storage capacity and data redundancy. The different redundant arrays have different RAID level. Each RAID level has its own data protection, data availability and performance degree.

RAID Level

RAID Level	Description	Min. HDD Needed
RAID0	RAID 0 is called striping. RAID 0 is to save the continued data fragmentation on several HDDs. It can process the read and write at the same time, so its read/write speed is N (N refers to the HDD amount of the RAID 0) times as many as one HDD. RAID 0 does not have data redundant, so one HDD damage might result in data loss that cannot be restored.	2
RAID1	It is also called mirror or mirroring. RAID 1 data is written to two HDDs equally, which guarantee the system reliability and can be repaired. RAID 1 read speed is almost close to the total volume of all HDDs. The write speed is limited by the slowest HDD. At the same time, the RAID 1 has the lowest HDD usage rate. It is only 50%.	2
RAID5	RAID5 is to save the data and the corresponding odd/even verification information to each HDD of the RAID5 group and save the verification information and corresponding data to different HDDs. When one HDD of the RAID5 is damaged, system can use the rest data and corresponding verification information to restore the damaged data. It does not affect data integrity.	3
RAID6	Based on the RAID5, RAID6 adds one odd/even verification HDD. The two independent odd/even systems adopt different algorithm, the data reliability is very high. Even two HDDs are broken at the same time, there is no data loss risk. Comparing to RAID5, the RAID6 needs to allocate larger HDD space for odd/even verification information, so its read/write is even worse.	4
RAID10	RAID 10 is a combination of the RAID 1 and RAID 0. It uses the extra high speed efficient of the RAID 0 and high data protection and restores capability of the RAID 1. It has high read/write performance and security. However, the RAID 10 HDD usage	4

RAID Level	Description	Min. HDD Needed
	efficiency is as low as RAID 1.	
RAID50	RAID50 is a combination of the RAID5 and RAID0. It has higher fault-tolerance. There is no data loss even one HDD in the set malfunctions.	6
RAID60	RAID60 is a combination of the RAID6 and RAID0. It has higher fault-tolerance and read performance. There is no data loss even two HDDs in one set malfunctions.	8

RAID Capacity

See the sheet for RAID space information.

Capacity N refers to the mini HDD amount to create the corresponding RAID.

RAID Level	Total Space of the N HDD
RAID0	The total amount of current RAID group
RAID1	Min (capacityN)
RAID5	$(N-1) \times \text{min (capacityN)}$
RAID6	$(N-2) \times \text{min (capacityN)}$
RAID10	$(N/2) \times \text{min (capacityN)}$
RAID50	$(N-2) \times \text{min (capacityN)}$
RAID60	$(N-4) \times \text{min (capacityN)}$

Appendix 3 HDD Capacity Calculation

HDD capacity calculation formula:

Total capacity (M) = Channel number × Demand time length (hour) × HDD capacity occupied per hour (M/hour)

According to the above formula, get recording time calculation formula.

$$\text{Recording time (hour)} = \frac{\text{Total capacity (M)}}{\text{HDD capacity occupied per hour (M/hour)} \times \text{Channel number}}$$

For example, for single-channel recording, HDD capacity occupied per hour is 200M/hour. Use 4-channel device to make 24-hour continuous recording in every day of one month (30 days), the required HDD space is: 4 channels × 30 days × 24 hours × 200M/hour = 576G. Therefore, five 120G HDD or four 160G HDD shall be installed.

According to the above formula, at different stream values, recording file size of 1 channel in 1 hour is shown as follows (for your reference):

Bit stream size (max.)	File size	Bit stream size (max.)	File size
≤ 96K	42M	128K	56M
160K	70M	192K	84M
224K	98M	256K	112M
320K	140M	384K	168M
448K	196M	512K	225M
640K	281M	768K	337M
896K	393M	1024K	450M
1280K	562M	1536K	675M
1792K	787M	2048K	900M

Appendix 4 Glossary

Name	Description
CGI	Common Gateway Interface (CGI) is an important Internet technology. With CGI, client can ask data from program running on network server. CGI describes data transmission standard between server and asking processing program.
DDNS	Dynamic Domain Name System (DDNS) is to map the user dynamic IP address to a specified domain analysis service. Each time, when the user connects to the network, the client can transmit the host dynamic address to the server application on the host of the service provider. The server applications are to provide the DNS service and realize dynamic domain analysis. That is to say, the user does not need to remember the changeable IP address, just uses the domain name to login the device or the address.
DHCP	Dynamic Host Configuration Protocol (DHCP) is a network protocol in the LAN. It is to automatically allocate IP address for the internal network or the ISP (Internet service provider).It is to manage the computer IP address by the unified means of management.
DNS	Domain Name System (DNS) is to save the all host domain name and corresponding IP address in the network. It has the ability to change the domain to the IP address.
DVR	Digital Video Recorder.
FTP	File Transfer Protocol (FTP) is used to control bilateral transmission of file on the Internet.
HDMI	High Definition Multimedia Interface (HDMI) is a special digital interface suitable for audio/video transmission. It can transmit audio signal and video signal at the same time.
HTTPS	Hyper Text Transfer Protocol over Secure Socket Layer (HTTPS) is a HTTP channel for security purpose. The HTTPS has defines the browser the world wide web service safety communication rule. It adopts encryption technology to guaranty safety access to the webpage.
IP	Internet Protocol.
IPC	IP Camera.
NTP	Network Time Protocol (NTP) is a protocol to synchronize computer time. It adopts wireless network protocol UDP, so that the computer time synchronizes with the server or the time source. It is to provide time correction of high accuracy.
NTSC	National Television Standards Committee, American national standard television and broadcast transmission and receiving protocol. This is a television standard that television scanning beam is 525 beams, 30 frames per second, interlaced scanning, odd field first and then it is followed by even field. NTSC is used in the United States of America, Japan, and so on.
NVR	Network Video Recorder
MTU	Maximum Transmission Unit (MTU) refers to the maximum data packet amount (byte) on one layer of the communication protocol.

Name	Description
ONVIF	Open Network Video Interface Forum (ONVIF) is the defined general protocol for information exchange among the network video devices. It includes search device, real-time audio/video, metadata, information control, and so on.
PAL	Phase Alteration Line, this is a television standard that television scanning beam is 625 beams, 25 frames per second, phase alteration, odd field first and then it is followed by even field. PAL color encoding is used. PAL is used in China, Europe, and so on.
PTZ	Pan Tilt Zoom (PTZ) refers to the PTZ all-direction movement, lens zoom, and focus control.
RAID	RAID is an abbreviation for Redundant Array of Independent Disks. It is to combine several independent HDDs (physical HDD) to form a HDD group (logic HDD), to provide higher storage performance and data redundancy.
S.M.A.R.T	Self-Monitoring Analysis and Reporting Technology (S.M.A.R.T) is a technical standard to detect HDD drive status and report potential problems.
SSH	Secure Shell (SSH) is a security protocol formulated by IETF network group on the basis of application layer. SSH protocol can effectively prevent information leakage problem during remote management.
SVC	Scalable Video Coding (SVC) is a video encoding technology. It can split the video streams to one basic layer and several enhanced layers according to the requirements. The basic layer provides the general video quality, frame rate and resolution, and the enhanced layer is to perfect the video quality.
VGA	Video Graphics Array (VGA) is a video transmission standard. It has high resolution, high display speed and abundant colors.
WLAN	Wireless Local Area Networks (WLAN) adopts radio frequency to realize data transmission.

Appendix 5 Cybersecurity Recommendations

Cybersecurity is more than just a buzzword: it's something that pertains to every device that is connected to the internet. IP video surveillance is not immune to cyber risks, but taking basic steps toward protecting and strengthening networks and networked appliances will make them less susceptible to attacks. Below are some tips and recommendations on how to create a more secured security system.

Mandatory actions to be taken for basic equipment network security:

1. Use Strong Passwords

See the following suggestions to set passwords:

- The length should not be less than 8 characters;
- Include at least two types of characters; character types include upper and lower case letters, numbers and symbols;
- Do not contain the account name or the account name in reverse order;
- Do not use continuous characters, such as 123, abc, etc.;
- Do not use overlapped characters, such as 111, aaa, etc.;

2. Update Firmware and Client Software in Time

- According to the standard procedure in Tech-industry, we recommend to keep your equipment (such as NVR, DVR, IP camera, etc.) firmware up-to-date to ensure the system is equipped with the latest security patches and fixes. When the equipment is connected to the public network, it is recommended to enable the "auto-check for updates" function to obtain timely information of firmware updates released by the manufacturer.
- We suggest that you download and use the latest version of client software.

"Nice to have" recommendations to improve your equipment network security:

1. Physical Protection

We suggest that you perform physical protection to equipment, especially storage devices. For example, place the equipment in a special computer room and cabinet, and implement well-done access control permission and key management to prevent unauthorized personnel from carrying out physical contacts such as damaging hardware, unauthorized connection of removable equipment (such as USB flash disk, serial port), etc.

2. Change Passwords Regularly

We suggest that you change passwords regularly to reduce the risk of being guessed or cracked.

3. Set and Update Passwords Reset Information Timely

The equipment supports password reset function. Please set up related information for password reset in time, including the end user's mailbox and password protection questions. If the information changes, please modify it in time. When setting password protection questions, it is suggested not to use those that can be easily guessed.

4. Enable Account Lock

The account lock feature is enabled by default, and we recommend you to keep it on to guarantee the account security. If an attacker attempts to log in with the wrong password several times, the corresponding account and the source IP address will be locked.

5. Change Default HTTP and Other Service Ports

We suggest you to change default HTTP and other service ports into any set of numbers between 1024–65535, reducing the risk of outsiders being able to guess which ports you are using.

6. Enable HTTPS

We suggest you to enable HTTPS, so that you visit Web service through a secure communication channel.

7. Enable Whitelist

We suggest you to enable whitelist function to prevent everyone, except those with specified IP addresses, from accessing the system. Therefore, please be sure to add your computer's IP address and the accompanying equipment's IP address to the whitelist.

8. MAC Address Binding

We recommend you to bind the IP and MAC address of the gateway to the equipment, thus reducing the risk of ARP spoofing.

9. Assign Accounts and Privileges Reasonably

According to business and management requirements, reasonably add users and assign a minimum set of permissions to them.

10. Disable Unnecessary Services and Choose Secure Modes

If not needed, it is recommended to turn off some services such as SNMP, SMTP, UPnP, etc., to reduce risks.

If necessary, it is highly recommended that you use safe modes, including but not limited to the following services:

- SNMP: Choose SNMP v3, and set up strong encryption passwords and authentication passwords.
- SMTP: Choose TLS to access mailbox server.
- FTP: Choose SFTP, and set up strong passwords.
- AP hotspot: Choose WPA2-PSK encryption mode, and set up strong passwords.

11. Audio and Video Encrypted Transmission

If your audio and video data contents are very important or sensitive, we recommend that you use encrypted transmission function, to reduce the risk of audio and video data being stolen during transmission.

Reminder: encrypted transmission will cause some loss in transmission efficiency.

12. Secure Auditing

- Check online users: we suggest that you check online users regularly to see if the device is logged in without authorization.
- Check equipment log: By viewing the logs, you can know the IP addresses that were used to log in to your devices and their key operations.

13. Network Log

Due to the limited storage capacity of the equipment, the stored log is limited. If you need to save the log for a long time, it is recommended that you enable the network log function to ensure that the critical logs are synchronized to the network log server for tracing.

14. Construct a Safe Network Environment

In order to better ensure the safety of equipment and reduce potential cyber risks, we recommend:

- Disable the port mapping function of the router to avoid direct access to the intranet devices from external network.
- The network should be partitioned and isolated according to the actual network needs. If there are no communication requirements between two sub networks, it is suggested to use VLAN, network GAP and other technologies to partition the network, so as to achieve the network isolation effect.
- Establish the 802.1x access authentication system to reduce the risk of unauthorized access to private networks.