



HD IR Mini Bullet Network Camera

Quick Start Guide

V1.0.1









Foreword

General

This Quick Start Guide (hereinafter referred to as "the Guide") introduces the functions, installation and operations of the camera.

Safety Instructions

The following categorized signal words with defined meaning might appear in the guide.

Signal Words	Meaning
 DANGER	Indicates a high potential hazard which, if not avoided, will result in death or serious injury.
 WARNING	Indicates a medium or low potential hazard which, if not avoided, could result in slight or moderate injury.
 CAUTION	Indicates a potential risk which, if not avoided, may result in property damage, data loss, lower performance, or unpredictable result.
 ELECTRICITY	Indicates dangerous high voltage. Take care to avoid coming into contact with electricity.
 LASER BEAM	Indicates a laser radiation hazard. Take care to avoid exposure to a laser beam.
 ESD	Electrostatic Sensitive Devices. Indicates a device that is sensitive to electrostatic discharge.
 TIPS	Provides methods to help you solve a problem or save you time.
 NOTE	Provides additional information as the emphasis and supplement to the text.

Revision History

No.	Version	Revision Content	Release Date
1	V1.0.0	First release.	March 2018
2	V1.0.1	Add model B in "3.3.2 Installing SD Card (Optional)."	January 2019

About this Guide

- This guide is for reference only. Please refer to the actual product for more details.
- Minor differences might be found in user interface, and there might be deviation between the actual value of some data and the value provided in the guide due to the reasons such

as the real environment is not stable. Please refer to the final explanation of the company if there is any doubt or dispute.

- All the designs and software are subject to change without prior written notice. The guide will be regularly updated according to the product upgrade without prior announcement.
- Please contact the supplier or customer service if there is any problem occurred when using the device.
- Please contact the customer service for the latest procedure and supplementary documentation.
- Please visit our website or contact your local service engineer for more information.
- The company is not liable for any loss caused by the operation that does not comply with the guide.
- If there is any uncertainty or controversy, please refer to our final explanation.

Important Safeguards and Warnings

Electrical safety

- All installation and operation should conform to your local electrical safety codes.
- The power source shall conform to the requirement of the Safety Extra Low Voltage (SELV) standard, and supply power with rated voltage which conforms to Limited power Source requirement according IEC60950-1. Please note that the power supply requirement is subject to the device label.
- Make sure the power supply is correct before operating the device.
- A readily accessible disconnect device shall be incorporated in the building installation wiring.
- Prevent the power cable from being trampled or pressed, especially the plug, power socket and the junction extruded from the device.
- We assume no liability or responsibility for all the fires or electrical shock caused by improper handling or installation.

Environment

- Do not aim the device at strong light to focus, such as lamp light and sun light, otherwise it might cause over brightness or light marks, which are not the device malfunction, and affect the longevity of Complementary Metal-Oxide Semiconductor (CMOS).
- Do not place the device in a damp or dusty environment, extremely hot or cold temperatures, or the locations with strong electromagnetic radiation or unstable lighting.
- Keep the camera away from water or other liquid to avoid damages to the internal components.
- Keep the indoor device away from rain or damp to avoid fire or lightning.
- Keep sound ventilation to avoid heat accumulation.
- Transport, use and store the device within the range of allowed humidity and temperature.
- Heavy stress, violent vibration or water splash are not allowed during transportation, storage and installation.
- Pack the device with standard factory packaging or the equivalent material when transporting the device.
- The device needs to be installed in the location where professional staff can cover (professionals need to know the attentions of using the device), non-professionals are not allowed to enter device installation area when the device is operating normally, which may cause accidental damage.

Operation and Daily Maintenance

- Do not directly touch the heat dissipation component of the device to avoid scald.
- Do not dismantle the device because there is no component that can be fixed by users themselves. Otherwise, it might cause water leakage or bad image due to unprofessional

dismantling.

- Please contact after-sale service to replace desiccant when it turns green (The desiccant is not provided by default).
- It is recommended to use the device together with lightning arrester to improve lightning protection effect.
- It is recommended to get the grounding holes to be grounded to enhance the reliability of the device.
- Do not directly touch the optic component CMOS. You can use the air blower to blow away the dust or dirt on the lens surface. Please use a dry cloth wetted by alcohol to wipe away the dust gently if necessary.
- Use the dry soft cloth to clean the device. If the dust is difficult to be removed, please wipe it away with a clean cloth wetted slightly by the mild detergent, and then use the dry cloth to clean the device. Do not use volatile solvents like alcohol, benzene, thinner, or strong detergent with abrasiveness, otherwise it will damage the surface coating or reduce the working performance of the device.
- When installing or using the device, do not directly touch or wipe the surface of the dome cover because it is an optical device. If stained with dirt, use oil-free soft brush or air blower to gently wipe it away. If stained with grease or fingerprint, use soft cloth to gently wipe the water drop or oil and wait till it is dry, and then use oil-free cotton cloth or lens cleaning paper soaked with alcohol or detergent to wipe from the lens center outward till it is clean.
- We are not liable for any problems caused by unauthorized modification or attempted repair.
- The dome cover is a kind of optical component, please do not touch or wipe the cover surface during installation and application, it may stain dust, grease or fingerprint, you can use absorbent cotton to dip some diethyl ether or use soft cloth to dip some water and then wipe gently. You can also use air gun to remove the dust if the cover is stained with dust.

Warnings

- Please strengthen the protection of network, device data and personal information, adopt necessary measures of guarantee device network security, including but not limited to using strong password, modifying password regularly, upgrading firmware to the latest version, isolating computer network and so on. For the IP camera firmware of some old version, the ONVIF password won't be modified automatically after the main password of the system is modified. You need to upgrade the camera firmware or upgrade the ONVIF password manually.
- Please modify the default password after login to avoid being stolen.
- Use the standard components provided by manufacturer and make sure the device is installed and fixed by professional engineers.
- The surface of the image sensor should not be exposed to laser beam radiation in an environment where a laser beam device is used.
- Do not provide two or more power supply sources for the device; otherwise it might damage the device.

Regulatory Information

FCC Information

FCC conditions:

This device complies with part 15 of the FCC Rules. Operation is subject to the following two conditions:

- This device may not cause harmful interference.
- This device must accept any interference received, including interference that may cause undesired operation.

FCC compliance:

This equipment has been tested and found to comply with the limits for a digital device, pursuant to part 15 of the FCC Rules. These limits are designed to provide reasonable protection against harmful interference. This equipment generate, uses and can radiate radio frequency energy and, if not installed and used in accordance with the guide, may cause harmful interference to radio communication. However, there is no guarantee that interference will not occur in a particular installation. If this equipment does cause harmful interference to radio or television reception, which can be determined by turning the equipment off and on, the user is encouraged to try to correct the interference by one or more of the following measures:

- Reorient or relocate the receiving antenna.
- Increase the separation between the equipment and receiver.
- Connect the equipment into an outlet on a circuit different from that to which the receiver is connected.
- Consult the dealer or an experienced radio/TV technician for help.

Table of Contents

Foreword	I
Important Safeguards and Warnings	III
Regulatory Information	V
1 Introduction	1
1.1 Cable	1
2 Network Configuration	2
2.1 Initializing Device	2
2.2 Modifying Device IP Address	3
2.3 Logging in Web Interface	4
3 Installation	6
3.1 Packing List.....	6
3.2 Dimension	6
3.3 Installing Device	7
3.3.1 Installation method.....	7
3.3.2 Installing SD Card (Optional).....	7
3.3.3 Attaching Device	9
3.3.4 Installing Waterproof Connector	10
3.3.5 Adjusting Sunshield	11
3.3.6 Adjusting Angle	12

1 Introduction

1.1 Cable



- Cable type might vary with different devices, and the actual product shall prevail.
- Please waterproof all the cable joints with insulating tape and waterproof tape to avoid short circuit and water damage. For the detailed operation, see the *FAQ Manual*.

Figure 1-1 Cable list

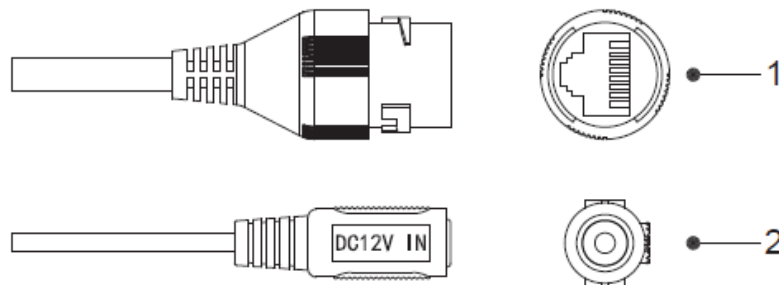

For more information about cable ports, see Table 1-1.

Table 1-1 Cable information

No.	Port Name	Function
1	Ethernet Port	<ul style="list-style-type: none">• Connects to network with network cable.• Provides power to the device with PoE. <p>PoE is available on select model.</p>
2	DC 12V Power Input	Inputs DC 12V power. Please be sure to supply power as instructed in the Guide. <p>Device abnormality or damage could occur if power is not supplied correctly.</p>

2 Network Configuration

Device initialization and IP setting can be finished with the "ConfigTool" or in web interface. For more information, see the *Web Operation Manual*.



- Device initialization is available on select models, and it is required at first use and after device is being reset.
- Device initialization is available only when the IP addresses of the device (192.168.1.108 by default) and the PC stays in the same network segment.
- Planning useable network segment properly to connect the device to the network.
- The following figures and interfaces are for reference only, and the actual product shall prevail.

2.1 Initializing Device

Step 1 Double-click "ConfigTool.exe" to open the tool.

Step 2 Click .

The **Modify IP** interface is displayed. See Figure 2-1.

Figure 2-1 Modify IP interface

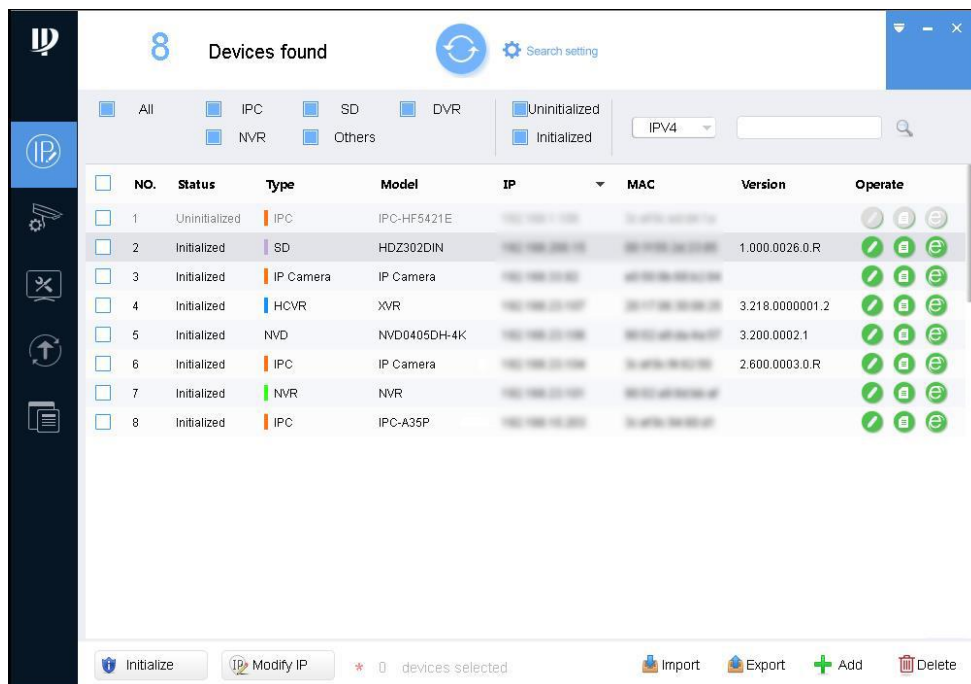

Step 3 Click **Search setting**.

The **Setting** interface is displayed.

Step 4 Enter the start IP and end IP of the network segment in which you want to search devices, and then click **OK**.

All the devices found in the network segment are listed.

Step 5 Select one or several devices which **Status** are **Uninitialized**, and then click **Initialize**.
The **Device initialization** interface is displayed.

Step 6 Select the devices that need initialization, and then click **Initialize**.
The password setting interface is displayed. See Figure 2-2.

Figure 2-2 Password setting interface

Step 7 Set and confirm the password of the devices, and then enter a valid email address.
Click **Next**.

The final setting interface is displayed.

 **NOTE**

Password can be modified or reset in **System Settings**.

Step 8 Select the options according to your needs and then click **OK**.

The **Initialization** interface is displayed after initializing is completed. Click the success icon (✓) or the failure icon (⚠) for the details.

Step 9 Click **Finish**.

The device status in the **Modify IP** interface (Figure 2-1) turns to **Initialized**.

2.2 Modifying Device IP Address



- You can modify IP address of one or multiple devices in one time. This section is based on modifying IP addresses in batch.
- Modifying IP addresses in batch is available only when the corresponding devices have the same login password.

Step 1 Double-click "ConfigTool.exe" to open the tool.

Step 2 Click .

The **Modify IP** interface is displayed. See Figure 2-1.

Step 3 Select the devices which IP addresses need to be modified, and then click **Modify IP**. The **Modify IP Address** interface is displayed. See Figure 2-3.

Figure 2-3 Modify IP address interface

The screenshot shows a web-based configuration window titled "Modify IP Address". It has a dark header bar with the title and a close button. The main content area contains a "Mode" section with two radio buttons: "Static" (which is selected) and "DHCP". Below the mode selection are three input fields: "Start IP", "Subnet Mask", and "Gateway", each containing a placeholder ".". To the right of the "Start IP" field is a checkbox labeled "Same IP". At the bottom of the window, there is a grey bar containing the text "Selected number of devices: 11" and an "OK" button.

Step 4 Select **Static** mode and enter start IP, subnet mask and gateway.

 **NOTE**

- IP addresses of multiple devices will be set to the same if you select **Same IP**.
- If DHCP server is available in the network, devices will automatically obtain IP addresses from DHCP server when you select **DHCP**.

Step 5 Click **OK**.

2.3 Logging in Web Interface

Step 1 Open IE browser, enter the IP address of the device in the address bar and press Enter.

If the setup wizard is displayed, follow the instructions to finish the settings.

Step 2 Enter user name and password in the login box, and then click **Login**.

Step 3 For first time login, click **Click Here to Download Plugin** and install the plugin as instructed.

The main interface is displayed when the installation is finished. See Figure 2-4.

Figure 2-4 Main interface

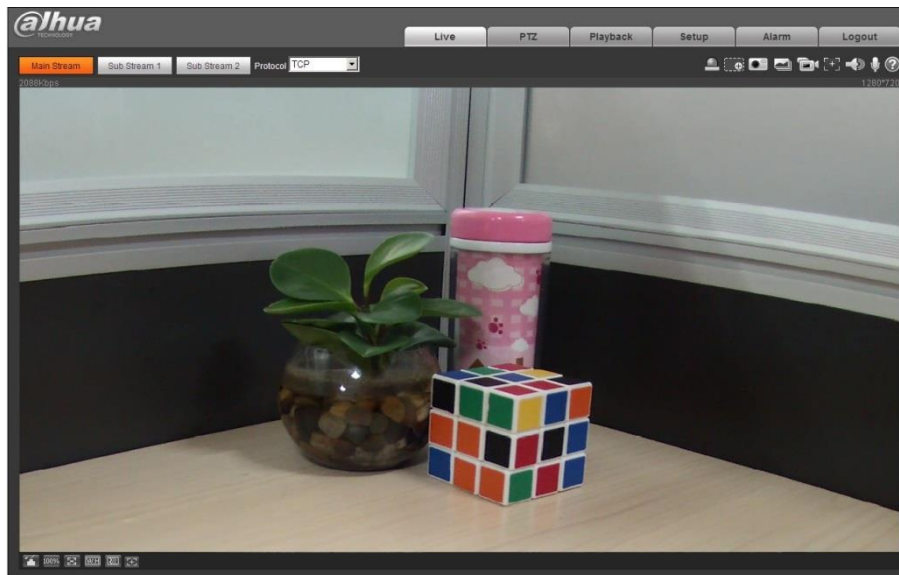

3 Installation

3.1 Packing List



- The tools required for the installation including electric drill is not provided in the packing.
- The operation manual and related tool are contained in the disk or the QR code, and the actual packing shall prevail.

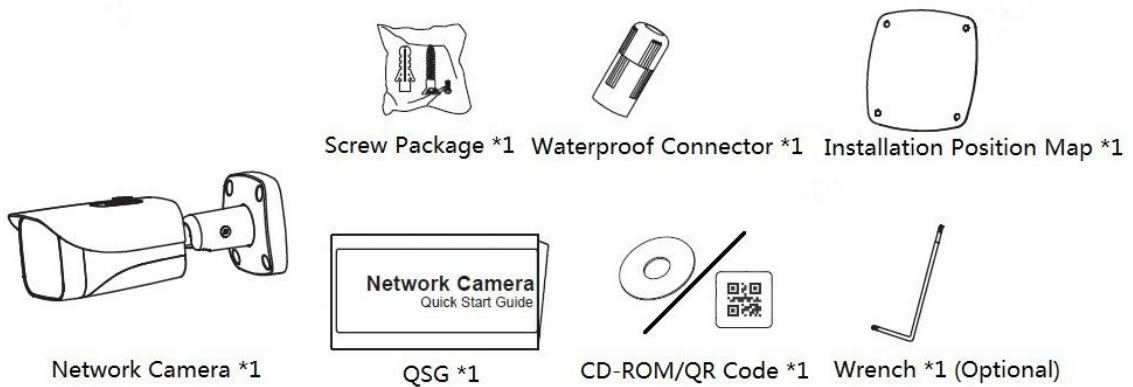

3.2 Dimension



Following figures are for reference only, the actual product shall prevail.

(Unit: mm [in])

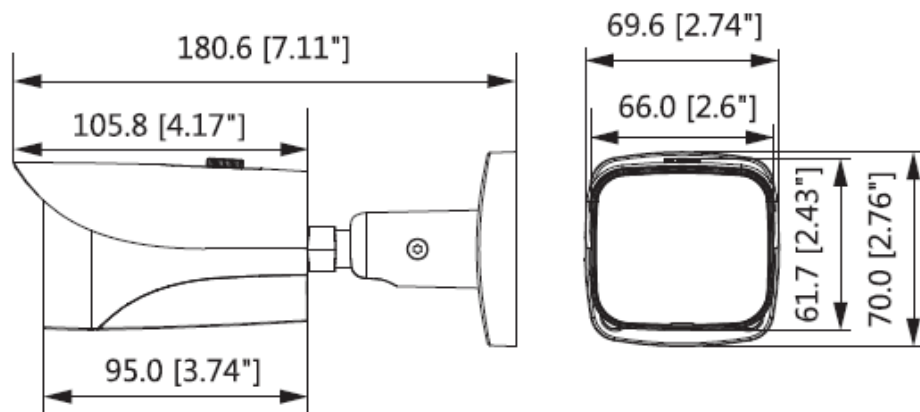

3.3 Installing Device

3.3.1 Installation method

Installation Type

Wall-mounted

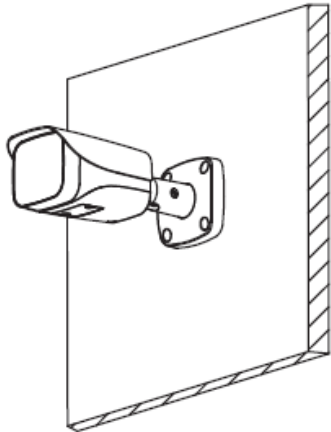

Pole-mounted

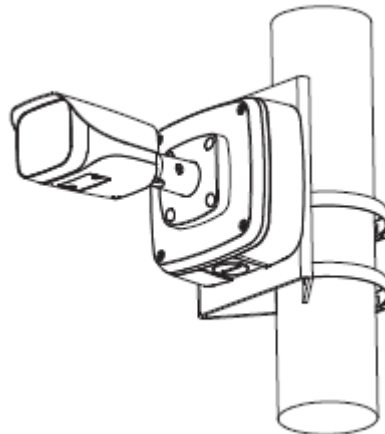

Corner-mounted

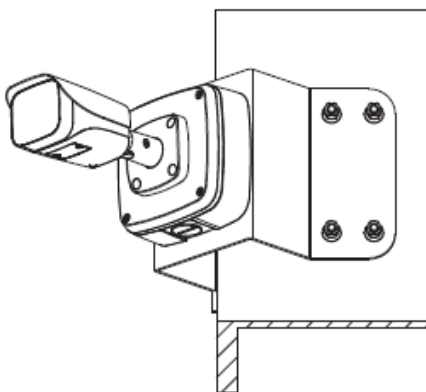

Ceiling-mounted

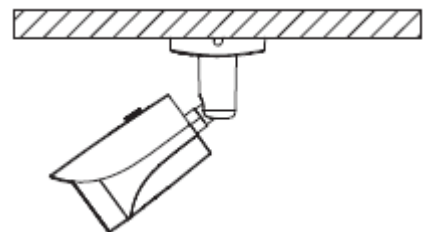

3.3.2 Installing SD Card (Optional)



- SD card slot is available on select models. Model A and Model B are defined according to the location of the SD card slot.
- Please disconnect the power from the device before installing the SD card.
- Press the reset button for 10 seconds to reset the device.

Model A

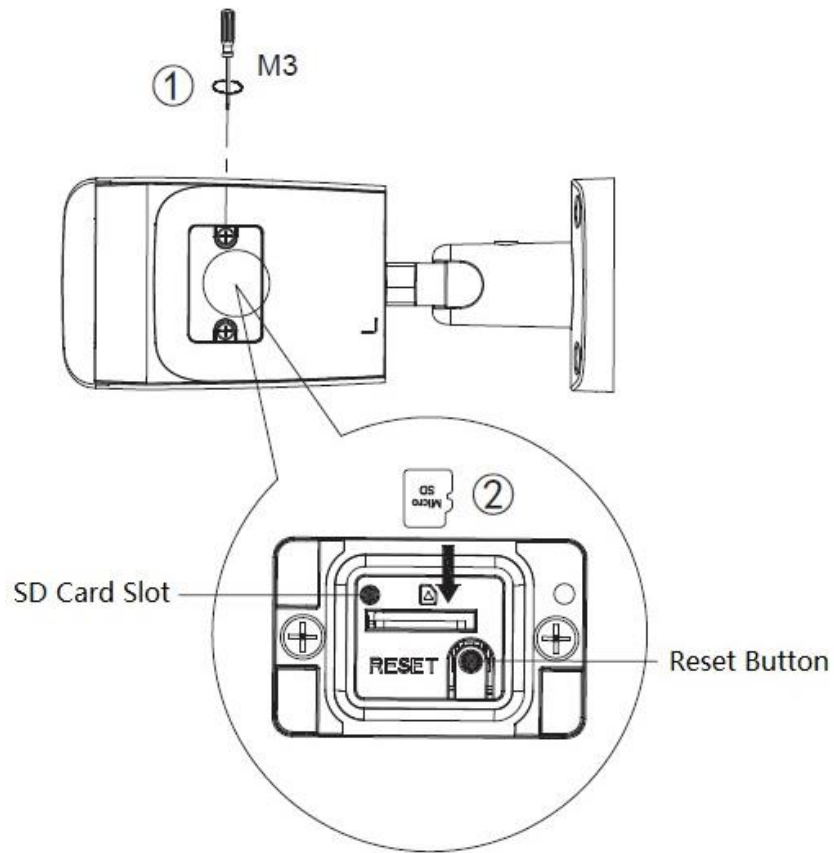

Model B

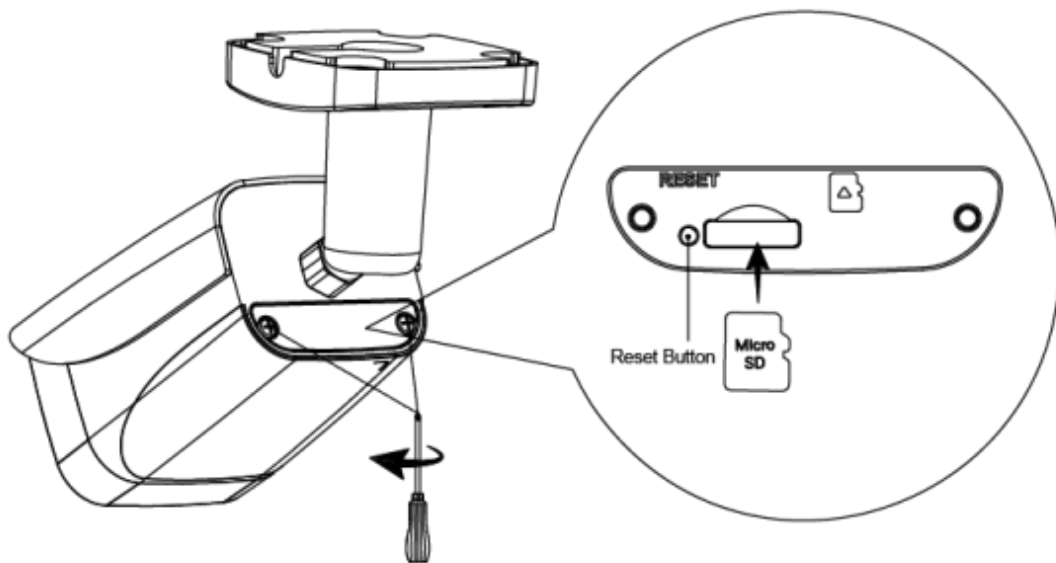

3.3.3 Attaching Device



Make sure the mounting surface is strong enough to hold at least three times of the device weight.

Cable going through the wall

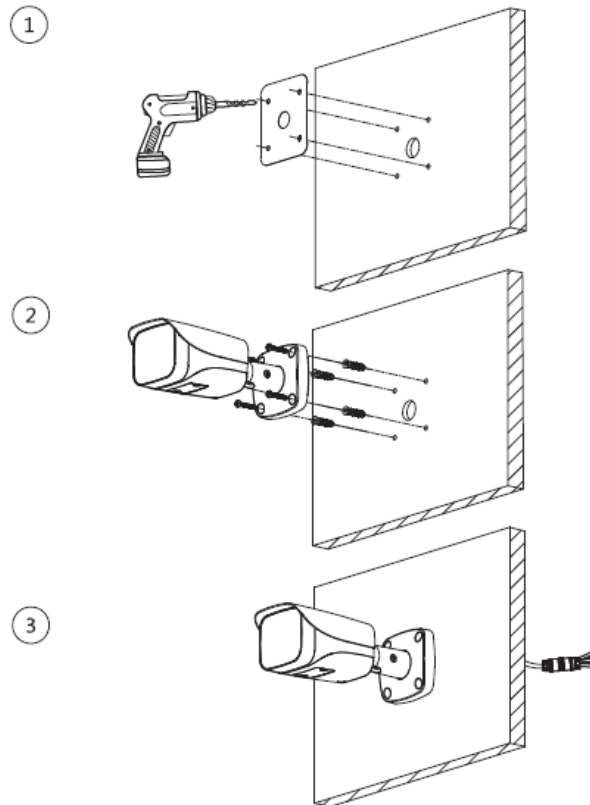

Cable going through the side cable tray

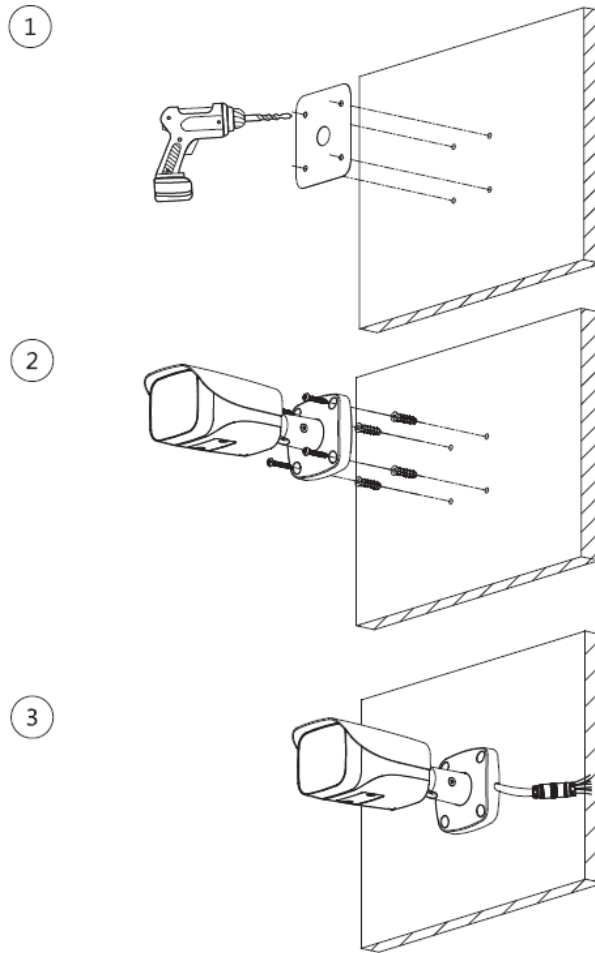

3.3.4 Installing Waterproof Connector



This part is only needed when there is waterproof connector come with the device and the device is used outdoor.

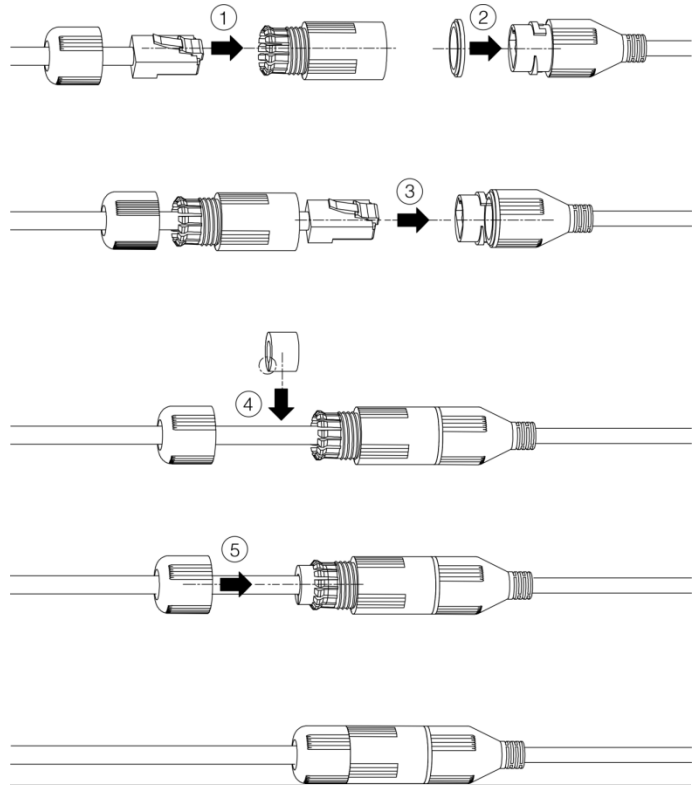

3.3.5 Adjusting Sunshield

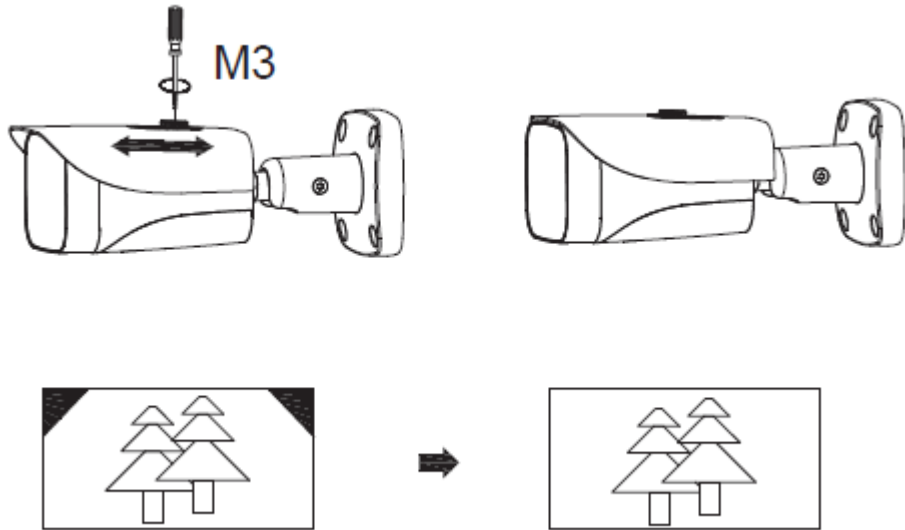

3.3.6 Adjusting Angle

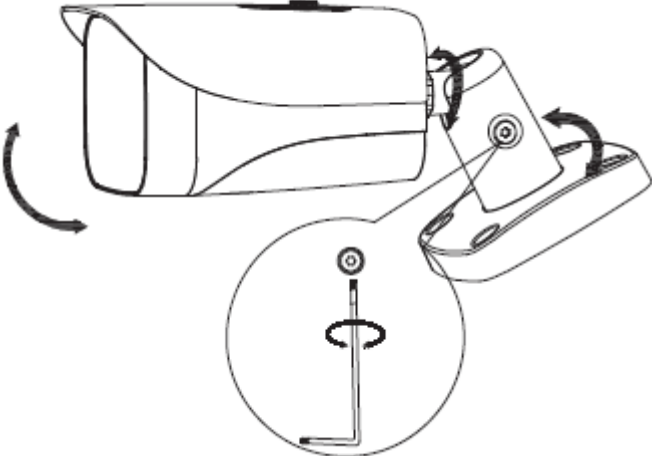

Zhejiang Dahua Vision Technology Co., Ltd

Address: No.1199 Bin'an Road, Binjiang District, Hangzhou, PRC.

Postcode: 310053

Tel: +86-571-87688883

Fax: +86-571-87688815

Email: overseas@dahuatech.com

Website: www.dahuasecurity.com