



360° Multi-sensor Panoramic Plus PTZ Dome Network Camera

DH-PSD81602N-A360

Quick Start Guide

Version 001.001

Dahua Technology USA Inc.

Table of Contents

1	Welcome.....	1
1.1	Important Safeguards and Warnings.....	1
	Electrical safety	1
	Environmental Precautions	2
	Operation and Daily Maintenance	3
	Lifting Appliance Requirement	3
	Warnings.....	3
1.2	FCC Information.....	4
	FCC compliance:	4
1.3	Legal Notices	4
	Copyright.....	4
	Trademarks.....	4
1.4	Disclaimer	5
2	Unpacking.....	6
2.1	Parts List	6
2.2	User-supplied Tools and Hardware.....	6
3	Installation and Configuration	7
3.1	Framework and Dimensions	7
3.2	Wiring.....	8
3.3	Locally Storing Data	9
3.4	Alarm Setup	9
	Alarm Input.....	9
	Alarm Output – Level Application	10
	Alarm Output – Switch Application	10
4	Device Installation	11
4.1	Preparing for Installation	11
	Removing Packing Material	11
	Installing an Optional MicroSD Card	12
4.2	Mounting the Camera to a Wall.....	13
5	Network Configuration	15
5.1	Network Protocols	15
5.2	Modifying the IP Address	16
5.3	Using the ConfigTool.....	16
5.4	Accessing the Web Interface	17
5.5	Configuring Alarms.....	18
5.6	Configuring Local SD Card Recording	19
6	Smart Track Configuration.....	21
6.1	Enabling Alarm Track.....	21
6.2	Setting the Calibration Parameters	21

1 Welcome

This manual offers reference material and general information about the basic operation, maintenance, and troubleshooting of the Dahua Multi-Sensor Panoramic Camera. Read, follow, and retain the following safety instructions. Heed all warning on the unit and in the operating instructions before operating the unit. Keep this guide for future reference.

1.1 Important Safeguards and Warnings

Electrical safety

- Install the unit in accordance with the manufacturer's instructions and in accordance with applicable local codes.
- All installation and operation must conform to your local electrical safety codes.
- Do not overload outlets and extension cords, which may cause fire or electrical shock.
- Do not place the camera near or in a place where the camera may contact overhead power lines, power circuits, or electrical lights.
- Ensure power conforms to SELV (Safety Extra Low Voltage) and that the limited power source is rated 36 VDC as specified in IEC60950-1. (Power supply requirement is subject to the device label).
- All input/output ports are SELV circuits. Ensure that SELV circuits are connected only to other SELV circuits.
- Ground the unit using the ground connection of the power supply to protect the unit from damage, especially in damp environments.
- Protect the plug and power cord from foot traffic, being pinched, and its exit from the unit.
- Units with or without an ON/OFF switch have power supplied to the unit whenever the power cord is inserted into the power source; however, the unit is operational only when the ON/OFF switch is in the ON position. The power cord is the main power disconnect device for switching off the voltage for all units.
- Operate the unit only from the type of power source indicated on the label. Before proceeding, disconnect the power from the cable to be installed into the unit.
 - For external power supplied units, use only the recommended or approved power supplies.
 - Limited power sources must comply with EN 60950. Substitutions may damage the unit or cause fire or shock.
 - For 24 VAC units, voltage applied to the unit's input power should not exceed $\pm 25\%$. User-supplied wiring must comply with local codes (Class 2 power levels). Do not ground the supply at the terminals or at the unit's power supply terminal.
 - Contact the local dealer or the power company to verify the correct power supply.
- Do not supply power via the Ethernet connection (PoE) when power is already supplied via the power connector.
- Do not attempt to service the unit. Opening or removing covers may expose you to dangerous voltage or other hazards. Refer all servicing to qualified personnel.

- If the unit is damaged and requires service, unplug the unit from the main AC power supply and from the PoE supply and refer to qualified service personnel. Damage may include, but is not limited to:
 - The power supply cord or plug is damaged.
 - Liquid has spilled in or on the unit.
 - An object has fallen on the unit.
 - The unit has been dropped and the housing is damaged.
 - The unit displays a marked change in performance.
 - The unit does not operate in the expected manner when the user correctly follows the proper operating procedures.
- Ensure a service technician uses replacement parts specified by the manufacturer, or that have the same characteristics as the original parts. Unauthorized parts may cause fire, electrical shock, or other hazards. Dahua is not liable for any damage or harm caused by unauthorized modifications or repairs.
- Perform safety checks after completion of service or repairs to the unit.
- Use attachments and accessories only specified by the manufacturer. Any change or modification of the equipment, not expressly approved by Dahua, could void the warranty.
- Incorporate a readily accessible disconnect device in the building installation wiring for quick power disconnect to the camera.
- Dahua assumes no liability or responsibility for any fire or electrical shock caused by improper handling or installation.

Environmental Precautions

- Do not aim the unit at a strong light source or into direct sunlight to focus. A strong light source may cause overexposure and may affect the longevity of the CCD or the CMOS sensor.
- Transport, use, and store the unit within the specified temperature and humidity range.
- Do not place the unit in a wet, dusty, extremely hot or an extremely cold environment; and avoid environments with strong electromagnetic radiation or unstable lighting.
- Never push objects of any kind into this unit through openings as they may touch dangerous voltage points or cause a short circuit that may result in fire or electrical shock. Take care to not spill any liquid on the unit.
- Do not use units intended for indoor applications near water, in damp or wet environments, or in any area classified as a wet location. Do not expose an indoor unit to rain or moisture to reduce the risk of fire or electric shock.
- Do not block or cover any openings in the unit enclosure. These openings are provided for ventilation to prevent overheating and to ensure reliable operation. Ensure the unit is placed in an area with adequate ventilation.
- Do not place the unit near a heat source such as heaters, stoves, radiators or other equipment that produces heat.
- Pack the unit with standard factory packaging or material of the same quality when transporting the unit.
- Take care to avoid heavy stress, violent vibration, or water spills to the camera unit during transportation, storage, and installation.

Operation and Daily Maintenance

- Do not touch the heat dissipation component of the unit. This part of the unit is hot and may cause a burn.
- Do not open or dismantle the device; there are no components that a user can fix or replace. Opening the unit may cause water leakage or expose components to direct light. Contact the manufacturer or a qualified service representative to service the camera or to replace a component, including the desiccant.
- Dahua recommends the use of a thunder-proof device in concert with the unit.
- Do not touch the CCD or the CMOS optic sensor. Use a blower to clean dust or dirt on the lens surface. Use a dry cloth dampened with alcohol and gently wipe away any dust on the lens.
- Use a dry soft cloth to clean the unit's housing. If the unit is particularly dusty, use water to dilute a mild detergent, apply the diluted detergent to a soft cloth, then gently clean the device. Finally, use a dry cloth to wipe the unit dry. Do not use a volatile solvent like alcohol, benzene, or thinner; or use a strong detergent with abrasives, which may damage the surface coating or reduce the working performance of the unit.
- Do not touch or wipe a dome cover during installation, this cover is an optical device. Refer to the following methods clean the dome cover:
 - Stained with dirt: Use an oil-free soft brush or blower to gently remove the dirt.
 - Stained with grease or fingerprints: Use a soft cloth to wipe gently the water droplet or the oil from the dome cover. Then, use an oil-free cotton cloth or paper soaked with alcohol or detergent to clean the lens from the center of the dome to outside. Change the cloth several times to ensure the dome cover is clean.

Lifting Appliance Requirement

- Select the proper installation mode and use the proper lifting device to safely lift the camera at the installation site.
- Ensure that the lifting device has the proper capacity to reach the installation height.
- Use the lifting device in accordance with its operating instructions and abide by the device's safety precautions.

Warnings

- Change the default password after the initial login to protect the integrity of the network.
- Use the standard accessories provided by the manufacturer and ensure the unit is installed and commissioned by qualified professionals.
- Protect the lens area from laser radiation when using a laser device to aid in installation and leveling of the unit.
- Do not supply power via the Ethernet connection (PoE) when power is already supplied via the power connector.

1.2 FCC Information

This device complies with part 15 of the FCC Rules. Operation is subject to the following two conditions:

- This device may not cause harmful interference;
- This device must accept any interference received, including interference that may cause undesired operation.

FCC compliance:

This equipment has been tested and found to comply with the limits for a digital device, pursuant to part 15 of the FCC Rules. These limits are designed to provide reasonable protection against harmful interference. This equipment generates uses and can radiate radio frequency energy and, if not installed and used in accordance with the instruction manual, may cause harmful interference to radio communication. However, there is no guarantee that interference will not occur in a particular installation. If this equipment does cause harmful interference to radio or television reception, which can be determined by turning the equipment off and on, the user is encouraged to try to correct the interference by one or more of the following measures:

- Reorient or relocate the receiving antenna.
- Increase the separation between the equipment and receiver.
- Connect the equipment into an outlet on a circuit different from that to which the receiver is connected.
- Consult the dealer or an experienced radio/TV technician for help.

1.3 Legal Notices

Copyright

This user guide is ©2017, Dahua Technology Company, LTD.

This user guide is the intellectual property of Dahua Technology Company, LTD and is protected by copyright. All rights reserved.

Trademarks

All hardware and software product names used in this document are likely to be registered trademarks and must be treated accordingly.

1.4 Disclaimer

- This user guide has been compiled with great care and the information it contains has been thoroughly reviewed and verified. The text was complete and correct at the time of printing. This guide may be periodically updated to reflect changes to the product or to correct previous information and the content of this guide can change without notice. If you encounter an error or have any questions regarding the contents of this guide, contact customer service for the latest documentation and supplementary information. Dahua accepts no liability for damage resulting directly or indirectly from faults, incompleteness, or discrepancies between this guide and the product described. Dahua is not liable for any loss caused by installation, operation, or maintenance inconsistent with the information in this guide.
- Video loss is inherent to all digital surveillance and recording devices; therefore Dahua cannot be held liable for any damage that results from missing video information. To minimize the occurrence of lost digital information, Dahua recommends multiple, redundant recording systems, and adoption of backup procedure for all data.
- Contact the supplier or customer service if you encounter any issue while using this unit.

2 Unpacking

This equipment should be unpacked and handled with care. If an item appears to have sustained damage during shipping, notify the shipper immediately.

Verify that all the parts listed below are included. If an item is missing, contact customer support or your local representative.

The original packing carton is the safest container to transport the unit, in the event the unit must be returned for service. Retain the carton and all shipping material for future use.

Please refer to the enclosed CD for more details, to view the detailed User's Manual, and for configuration software.

2.1 Parts List

Package Item	Quantity
Panoramic plus PTZ Network Dome Camera	1
DC36V/4.17A Power Supply	1
Mount Adapter	1
Wall Mount	1
Safety Tether	2
Hardware Bag	
Quick Start Guide	1
Documentation CD	1

2.2 User-supplied Tools and Hardware

Item	Quantity
Screwdriver	1
Bolts	4
Washers	4

3 Installation and Configuration

3.1 Framework and Dimensions

The following figures show the dimensions of the device in mm (in.). These images are intended as a reference only.

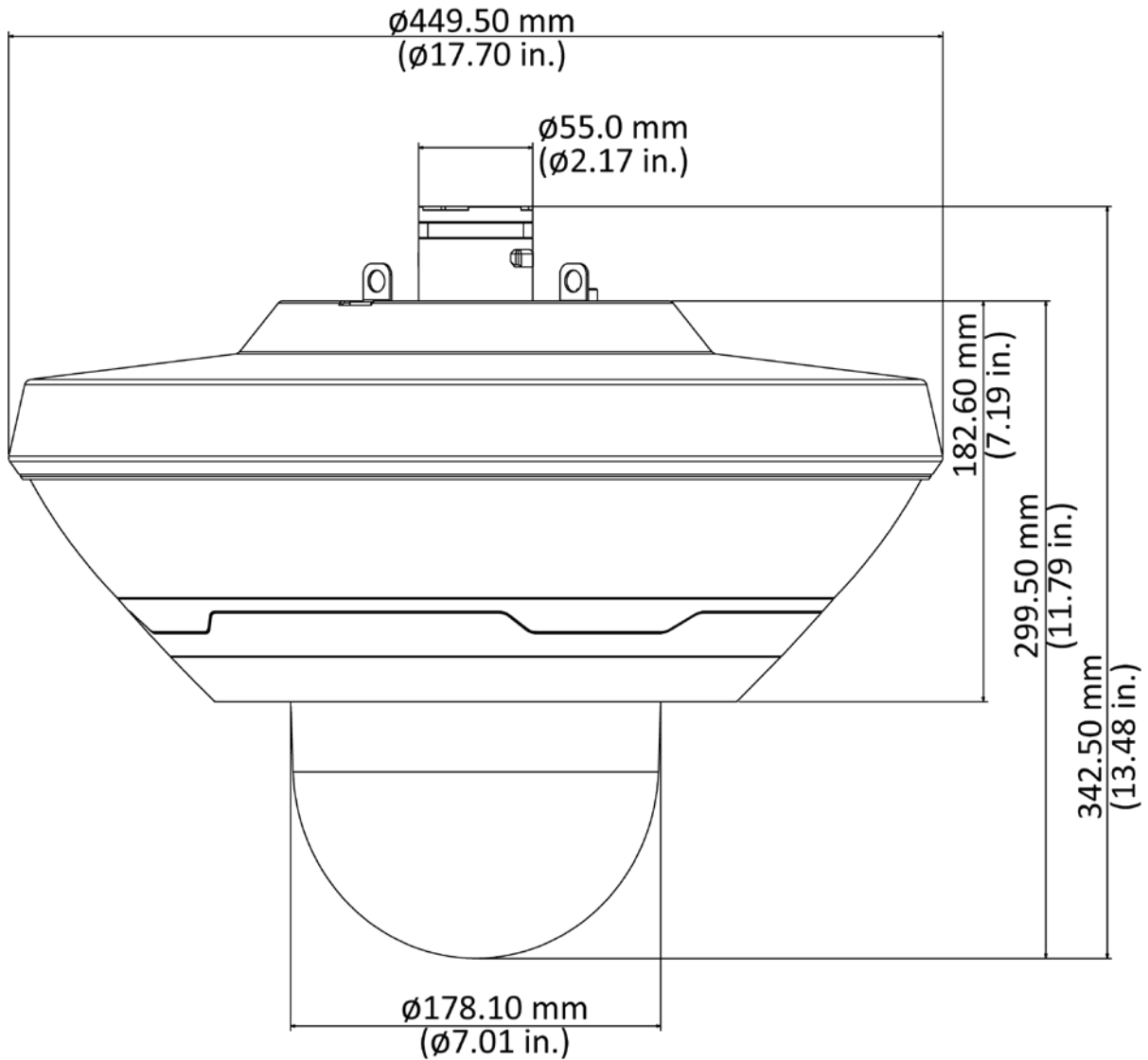

Figure 3-1

3.2 Wiring

Use the following illustration to identify the proper connections on the composite cable for the camera.

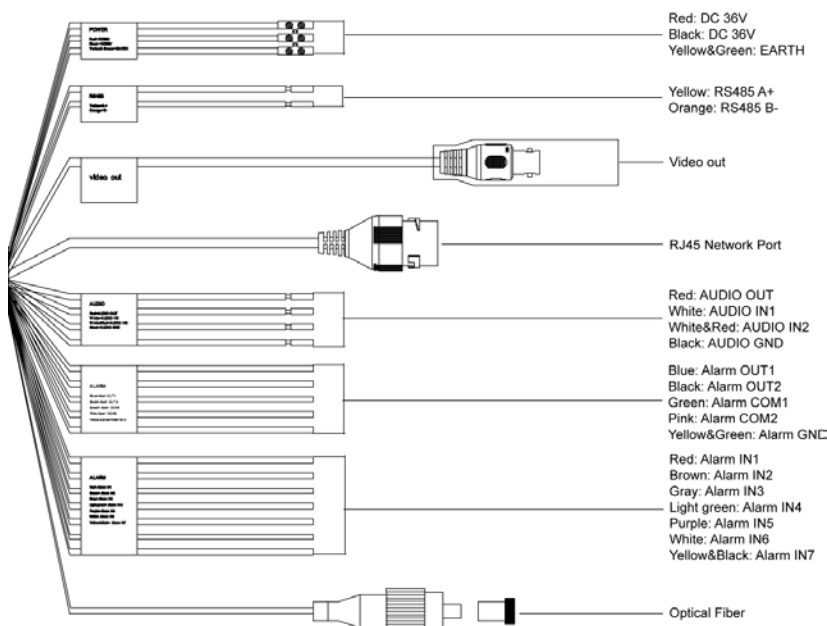

Figure 3-2

The dome camera includes the following wiring bundles:

	Wire Color	Connection
Power	Red	36 VDC
	Yellow/Green	Earth Ground
	Black	36 VDC
RS485	Yellow	RS485 A+
	Orange	RS485 B-
Video		Video Out
Network		Ethernet
Audio	Red	Audio Out
	White	Audio IN 1
	White/Red	Audio IN 2
	Black	Audio GND
Alarm OUT	Blue	Alarm OUT 1
	Black	Alarm OUT 2
	Green	Alarm COM 1
	Pink	Alarm COM 2
	Yellow/Green	Alarm GND
Alarm IN	Red	Alarm IN 1
	Brown	Alarm IN 2
	Gray	Alarm IN 3
	Light Green	Alarm IN 4
	Purple	Alarm IN 5
	White	Alarm IN 6
	Yellow/Black	Alarm IN 7
Optical Fiber		

3.3 Locally Storing Data

Certain cameras include a SDHC card slot for onboard storage that support a 128 GB Micro SD card. Dahua recommends using a SanDisk Extreme Micro SD card (or an equivalent substitute) as these cards have been fully tested without issue and the SanDisk Extreme line is better suited for constant recording. Lower-grade SD cards meant for multimedia applications will, at times, have questionable quality and reliability.

Recording to the SD card is first in first out (FIFO). The camera deletes the oldest (first) entry as new storage requirements arise. The camera does not signal nor make an indication when data is deleted. Storage time is dependent on a variety of factors such as SD card size, image resolution and video frames per second.

SD Recording supports video only. Audio is not supported.

3.4 Alarm Setup

Certain devices support alarm inputs and outputs, check your specific device for alarm capability.

Alarm Input

Refer to Figure 3-3 for alarm input configuration. The device collects that status of the alarm input port when the input signal is idle or grounded. If the input signal is connected to the 3.3 V or it is idle then the device receives the alarm input signal. If input signal is grounded, then no alarm input signal is detected.

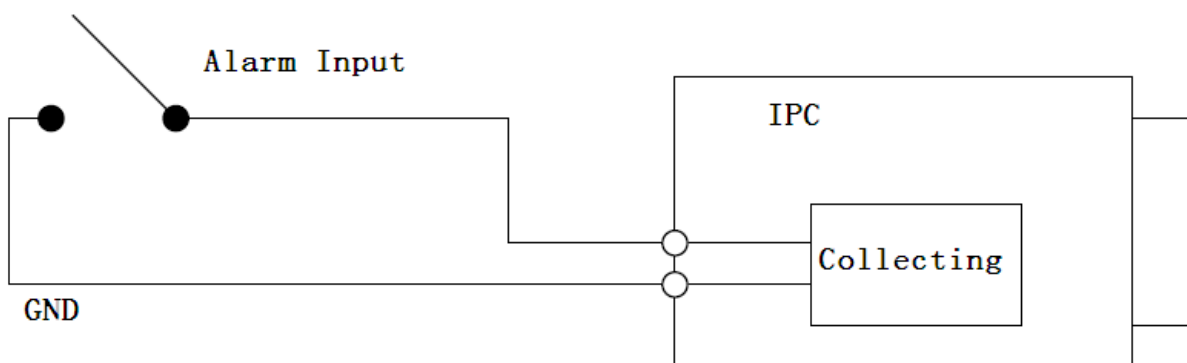

Figure 3-3

Alarm Output – Level Application

Use this alarm output configuration if the output triggers an external device by increasing the voltage. The alarm must increase the external pull-up resistance to trigger (high level) the device. The maximum external pull-up level is 5 V and the maximum port current is 5 mA. Once the output increases the pull-up resistance, the alarm decreases the output voltage to the normal state (low level) at less than 0.8 V.

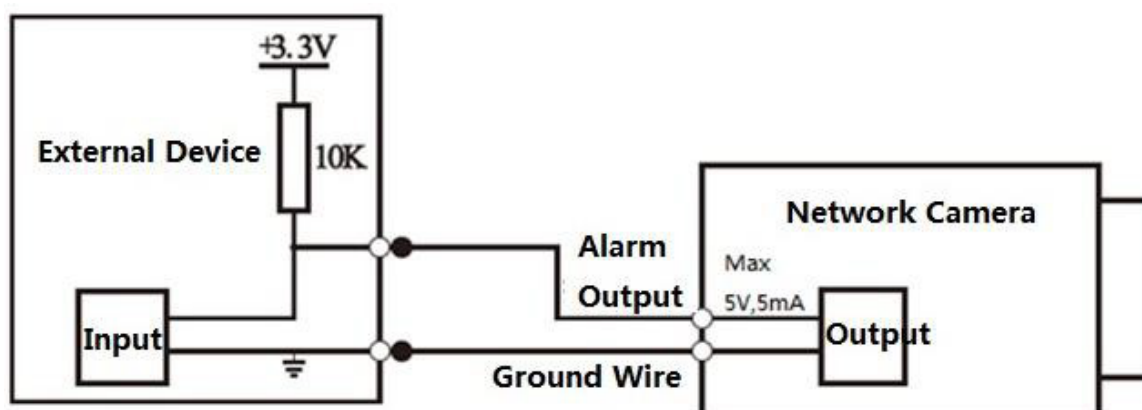

Figure 3-4

Alarm Output – Switch Application

The alarm output drives the external circuit, with a maximum current of 30 mA and a maximum voltage of 5 V. It is recommended to add a relay if the circuit exceeds the maximum values.

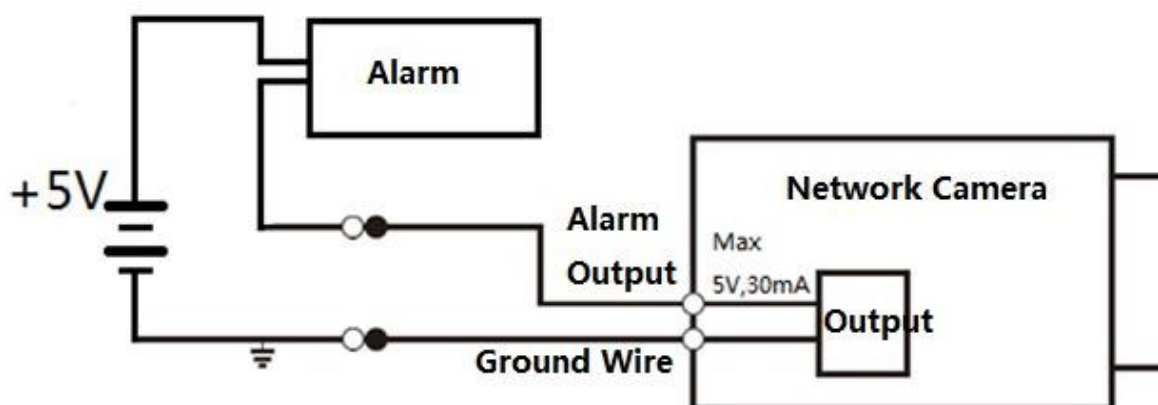

Figure 3-5

4 Device Installation

This section details installing the camera to a solid wall.

Caution: The wall must be capable of supporting a minimum of four (4) times the weight of the camera and the wall mount bracket.

Warning: DO NOT connect the camera to the power supply during installation.

Warning: For units intended to be installed outdoors: All wiring connecting to the unit must be routed separately inside a different permanently earthed metal conduits (not supplied).

Warning: Install external interconnecting cables in accordance to NEC, ANSI/NFPA70 (for US application) and Canadian Electrical Code, Part I, CSA C22.1 (for CAN application) and in accordance to local country codes for all other countries. Branch circuit protection incorporating a 20 A, 2-pole Listed Circuit Breaker or Branch Rated Fuses are required as part of the building installation. A readily accessible 2-pole disconnect device with a contact separation of at least 3 mm must be incorporated.

Note: Dahua recommends attaching a “drip loop” (flex or hard conduit) during installation to ensure condensation does not form in the mount or the conduit.

4.1 Preparing for Installation

The camera comes with a Mount Adapter and a Wall Mount, specifically made for the DH-PSD81602N-A360 camera. The installer must supply the following hardware:

- Four (4) bolts, washers or other fastening hardware to secure the wall mount to the installation medium. The hardware must be capable of supporting four (4) times the weight of the camera and mount.
- Appropriate tools to mount the camera to the wall.

Removing Packing Material

1. Remove the camera, the mount accessories, and any hardware packages from the boxes.
2. Remove the four screws from the top of the sunshield, and then remove the sunshield from the top of the camera. Discard the packing material between the sunshield and the camera. Reserve the screws.

Note: DO NOT leave the camera without the sunshield for more than 30 minutes to prevent water vapor entering the camera. Ensure you can complete this operation once started.

3. Replace the sunshield with the four screws.

Installing an Optional MicroSD Card

1. Insert an optional MicroSD card (maximum 128 GB):

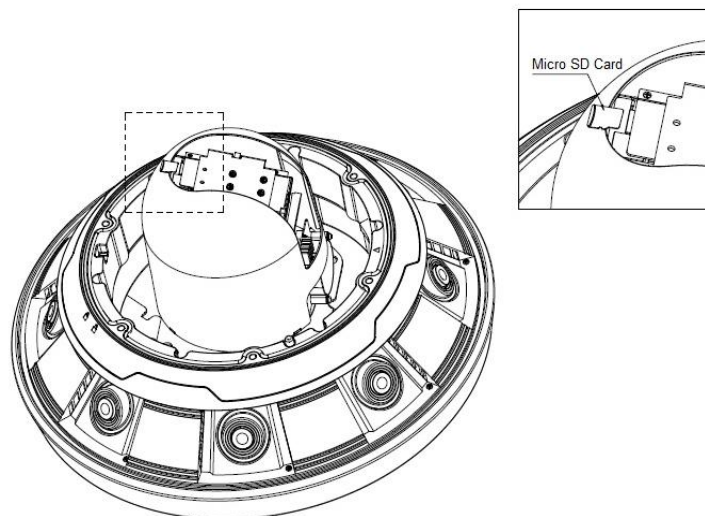

2. Rest the camera so that the PTZ Dome is facing up.
3. Remove the protective dome enclosure.
4. Locate the SD Card slot on the rear of the camera module.
5. Insert the SD Card into the slot until you hear a clicking sound, indicating the card is secure.
6. Replace the dome enclosure.

4.2 Mounting the Camera to a Wall

Use the following illustration as a reference to mount the camera to a wall using the Mount Adapter and the Wall Mount.

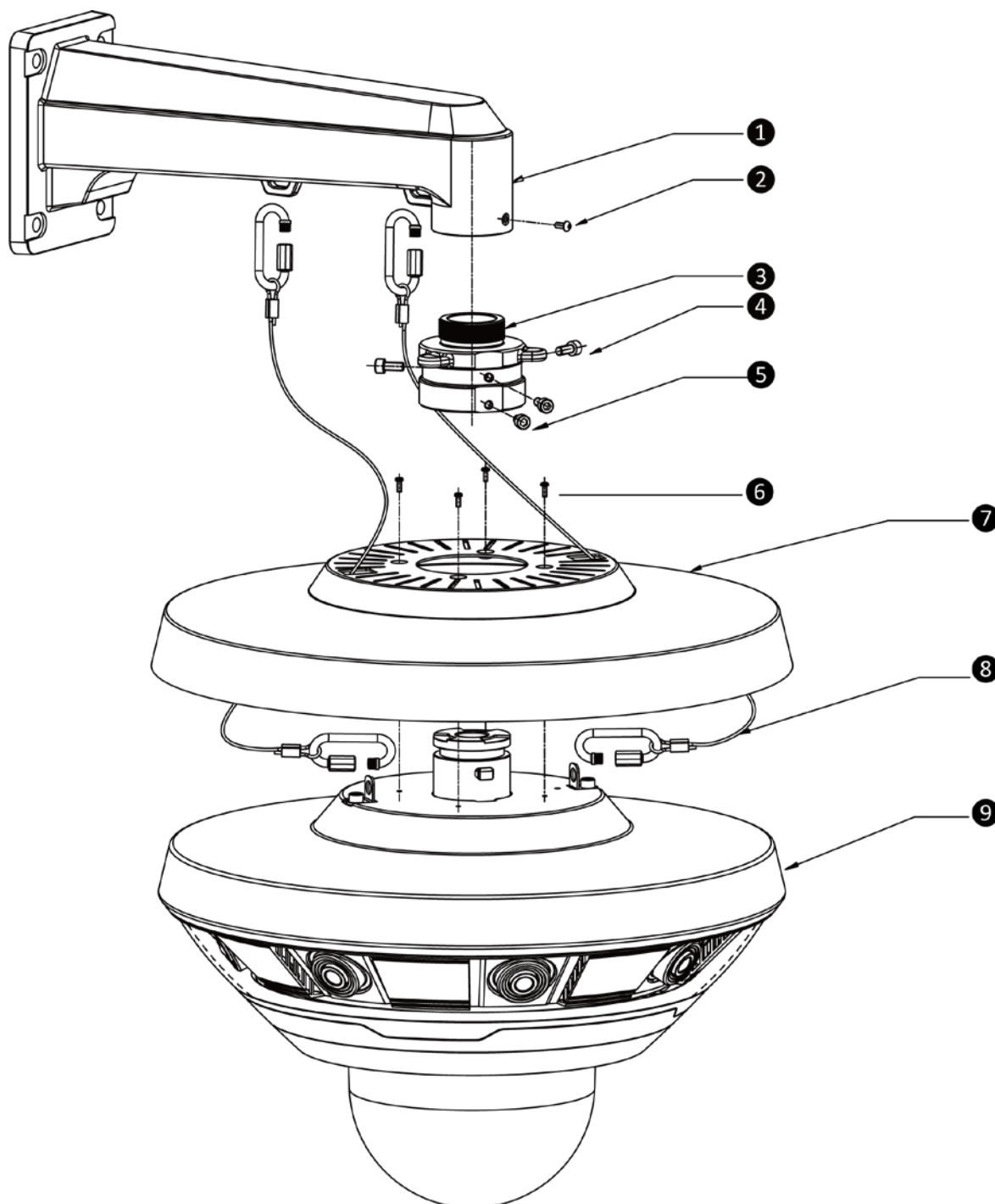
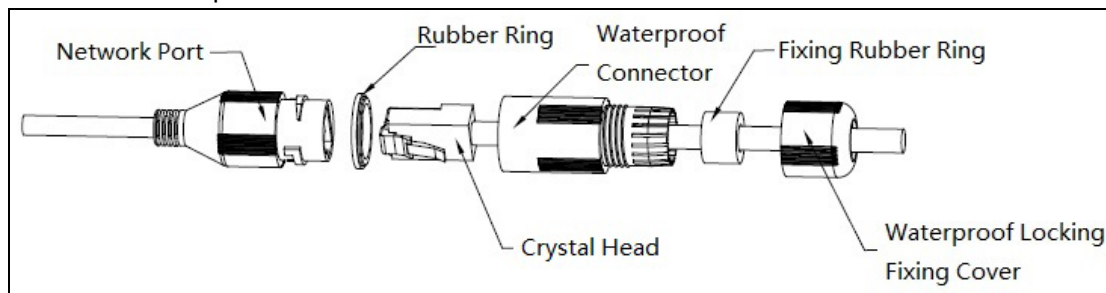

Figure 4-1

1	PFB303W Wall Mount	6	Sunshield Screw (x4)
2	Adapter Set Screw	7	Sunshield
3	PFA111 Mount Adapter	8	Safety Tether
4	Camera Set Screw (x3)	9	DH-PSD81602N-A360 Panoramic plus PTZ Camera
5	Locking Screw		

1. Place the Wall Mount Bracket (item 1, above) against the wall and mark the location of the four installation holes.
2. Pre-drill the four perimeter holes as marked on the wall for the fasteners, using a drill bit that is no wider than the fastener.
3. Drill a 50-mm (approximately 2 in.) center hole to route the cables, if necessary.
4. Insert an expansion bolt into each pre-drilled perimeter hole, if necessary.
5. Secure the wall mount to the wall using the four fasteners.
6. Loosen the adapter set screw (item 2), on the front of the wall mount.
7. Screw the Mount Adapter (item 3) into the internal thread of the wall mount until secure.
8. Tighten the adapter set screw on the wall mount to secure the adapter to the wall mount bracket.
9. Route the composite cable from the top of the camera through the mount adapter and the wall mount bracket and pull it out of the other end of the wall mount bracket.
10. Connect the external power, audio, alarm, RS485, and the video cables to the appropriate connectors on the camera's composite cable.
11. Attach the waterproof network connector if the camera is used outdoors.



- a. Place the wide side of the rubber ring onto the end of the network cable extending out from the camera.
 - b. Pull the waterproof cable end without the Ethernet connector through the body of the Waterproof Connector. Thread the cable through the Fixing Rubber Ring and the Waterproof Locking Cover.
 - c. Attach the male Ethernet connector to the network cable coming from the camera. Ensure the Waterproof Connector shroud covers the Ethernet connection.
 - d. Connect the other end of the waterproof connector to the network port and rotate it clockwise to lock the network port and waterproof connector firmly.
 - e. Slide the Waterproof Locking Cover over the main body of waterproof connector and rotate it clockwise to seal the connection.
12. Connect one end of a safety tether (item 8) to the loop on the top of the camera and then connect the other end of the safety tether to the corresponding loop on the wall mount bracket. Repeat this step to connect the other safety tether to the opposite side of the camera and the wall mount bracket.

Caution: Make sure to attach the safety tethers and ensure that both are securely fastened to the camera and to the wall mount to improve the safety and reliability of the installation.
 13. Align the top of the camera with the mount adapter so that the locking screw (item 5) on the mount adapter aligns with the locking port on the top of the camera.
 14. Tighten the locking screw on the mount adapter.
 15. Tighten the three (3) set screws (item 4) on the mount adapter to secure the camera to the mount adapter and to the wall mount bracket.

5 Network Configuration

Dahua IP cameras feature a built-in Web interface to control all aspects of camera operation. This section includes details about the supported network protocols, configuring IP addresses, and configuring alarms and local recording options. Refer to the camera's *Operations Manual* for full details.

5.1 Network Protocols

Dahua cameras support RTSP, RTP/TCP, RTP/UDP, HTTP, DHCP, TFTP, QoS, IP version 4 (IPv4) and IP version 6 (IPv6).

RTSP – Cameras communicate with video management systems over Real Time Streaming Protocol. Do not change the RTSP port unless you are sure your VMS does not use the default setting.

RTP/TCP – The Real-time Protocol/Transmission Control Protocol is best suited for applications that require high reliability, and transmission time is relatively less critical.

RTP/UDP – The Real-time Protocol/User Datagram Protocol is used for live unicast video, especially when it is important to always have an up-to-date video stream, even if some images are dropped.

HTTP – The Hypertext Transfer Protocol is an application protocol for distributed, collaborative, hypermedia information systems.

DHCP – The Dynamic Host Configuration Protocol allows network administrators to centrally manage and automate the assignment of IP addresses. DHCP should only be enabled if using dynamic IP address notification, or if the DHCP can update a DNS server.

TFTP – The Trivial File Transfer Protocol is a simple, lock-step, File Transfer Protocol which allows a client to get from or put a file onto a remote host. TFTP lacks security and most of the advanced features offered by more robust file transfer protocols such as File Transfer Protocol.

QoS – Quality of Service guarantees a certain level of a specified resource to selected traffic on a network. A QoS-aware network prioritizes network traffic and provides a greater network reliability by controlling the amount of bandwidth an application may use.

IPv4 – The IPv4 (IP version 4) is enabled by default and obtains the IP address automatically. The address can be used to allow or block network traffic that matches a specified address or protocol. The IP address must be valid for the network. For more information, contact your network administrator.

IPv6 – A typical IPv6 (IP version 6) node address consists of a prefix and an interface identifier (total 128 bits). The prefix is the part of the address where the bits have fixed values or are the bits that define a subnet. A typical IPv6 address may resemble the following example: 2001:db8::52:1:1. The IP address must be valid for the network. Before making changes to the IPv6 address, consult with your network administrator.

5.2 Modifying the IP Address

To operate the camera in your network you must assign it a valid network IP address. The default IP address is 192.168.1.108, but you may have to change this address if it conflicts with another device on the network.

To properly configure the camera for your network, you need the following information:

- Camera IP address – This address is an identifier for the camera on an IP network. For example, 140.11.2.115 is valid syntax for an IP address.
- Subnet mask – A mask is used to determine the subnet an IP address belongs to.
- Gateway IP address – This address is a node on a network that serves as an entrance to another network.
- Port – A port is an endpoint to a logical connection in an IP network.

Dahua supplies the ConfigTool to access and to modify the network settings of a device. Refer to the Operation Manual, available on the CD included with the camera or on Dahuasecurity.com, for complete information.

Notes:

- Ensure that the network parameters of each camera is available before starting configuration.
- The ConfigTool supports those cameras that are part of the same network that as the computer running the ConfigTool.

5.3 Using the ConfigTool

1. Install the ConfigTools.exe on a computer.
2. Adjust the computer's network settings so that it is on the same network as the camera.
3. Launch the ConfigTool to generate a list of devices on the network.
4. Click the IP button to modify the IP address.
5. Click Search Setting to open the Setting dialog box.

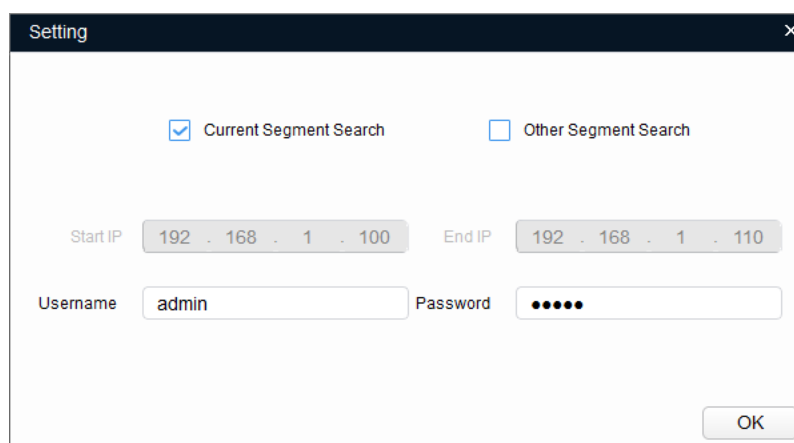

Figure 5-1

6. Click the Current Segment Search check box and enter the default Username and Password (“admin” for both) and click OK to search for the IP address of the device.
7. Double click the device to be configured, the ConfigTool opens the Modify IP Address dialog box.

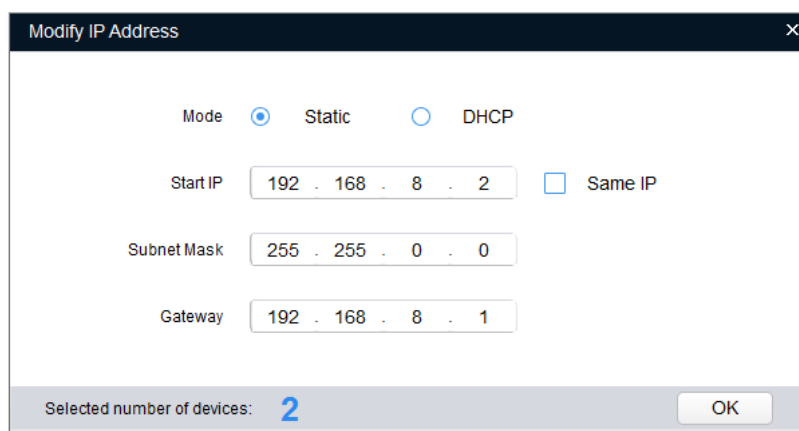

Figure 5-2

8. Set the Mode to Static and change the Start IP, Subnet Mask, and the Gateway addresses to match your network parameters and click OK.
9. If using a DHCP server, set the Mode to DHCP and click OK.

5.4 Accessing the Web Interface

Each camera can be accessed directly from the Internet Explorer Web browser. The Web Interface allows you to set camera parameter, configure alarm inputs and outputs, view live camera images, and review recorded video.

Note: Different devices may have different Web interfaces, the figures below are for reference only, and may not represent the Web Interface for your camera. Refer to the Web Operation Manual, included on the CD shipped with the camera, for more details.

1. Launch Internet Explorer and type the modified camera IP address in the address bar. Internet Explorer opens the Login page.
2. Type the Username and Password for the camera. (The default Username and Password is “admin”). Then, click Login.



Figure 5-3

3. Install the plug-ins according to the system prompt. Once the controls are installed IE displays the Web Interface main page.

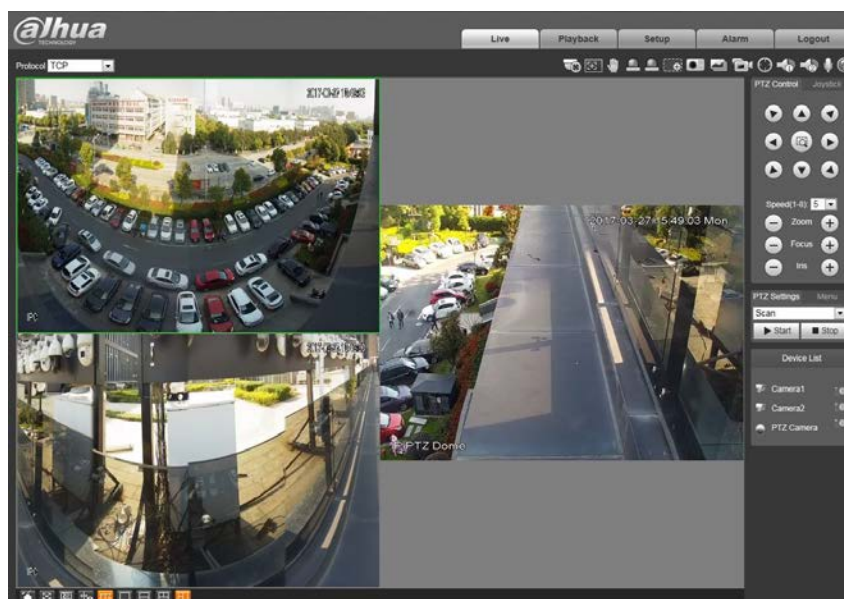

Figure 5-4

4. Modify the administrator password as soon as possible after you successfully logged in.

5.5 Configuring Alarms

The device's Web Interface offers a Relay Activation page to configure alarms and to set alarm responses.



Figure 5-5

1. Access the Web Interface for the device and click the Setup tab. Then, expand the Event menu, then choose the Alarm page. Set the alarm input and output parameters in the Relay Activation page.
2. Set the parameters for the alarm inputs. Check the Enable box to activate the chosen alarm input (Alarm 1 or Alarm 2). Set the sensor type for the alarm, either Normally Open (NO) or Normally Closed (NC).
3. Check the Relay Out box to enable the alarm activation function.

4. Select an alarm output port to activate a corresponding alarm device when an alarm occurs. Check Send Email to have the device send an email to alert when alarm occurs and ends. Check Snapshot to have the device automatically take a snapshot of the scene if alarm occurs.

5.6 Configuring Local SD Card Recording

The devices Web interface contains settings to control the recording medium and to configure an alarm that triggers once the Micro SD card passes a pre-determined storage.

1. Access the Web Interface for the device and click the Setup tab. Then, expand the Storage menu, then choose the Destination page.



Figure 5-6

2. Select the recording medium for each event Recorded and Snapshot event, Scheduled, Motion Detect and Alarm. Select the Local check box to record an event to the Micro SD card.
3. Click the Local tab to view the used capacity and the total capacity of the Micro SD card.



Figure 5-7

4. Expand the Event menu, located at the left of the Web interface, then select the Abnormality page to set alarms related to the Micro SD card. The contains the following Micro SD card alarm options:
 - No SD Card: Device triggers an alarm if the device does not contain a Micro SD card.
 - Capacity Warning: Device triggers an alarm when the data on the Micro SD card passes a defined threshold.
 - SD Card Error: Device triggers an alarm if it detects an issues writing data or retrieving data from the Micro SD card.



Figure 5-8

5. Select the event from the Event Type pull-down menu (No SD Card, Capacity Warning, SD Card Error).
6. Check the Enable box to activate the alarm for this event.
7. Check the Relay-out box to enable a relay alarm. Then, specify the time in seconds to delay the alarm relay output (10 s to 300 s).
8. Check the Send Email box to send an email to a specified user after the device triggers an alarm.
9. Set the capacity limit for the Micro SD Card (available with the Capacity Warning event type). The device triggers an alarm once the amount of data on the card surpasses this limit.



Figure 5-9

6 Smart Track Configuration

The Panoramic plus PTZ Dome camera includes the Smart Track feature that allows the PTZ camera to move to the position of an object in the 360° view and then track that object until it is beyond the tracking range of the PTZ camera. The camera uses the built-in Intelligent Video System, specifically Intrusion and Tripwire, to trigger the Smart Track function. You must enable the Alarm Track setting and set the calibration point for each sensor.

6.1 Enabling Alarm Track

1. Access the Web interface for the camera.
2. Click the Event menu from the left side of the main page.
3. Choose the Smart Track link, then click the Alarm Track tab.
4. Click the slider bar to enable Alarm Track.

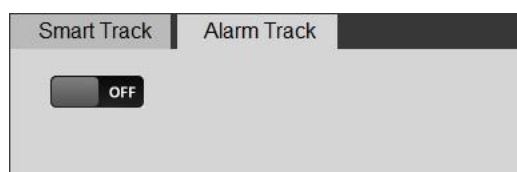

Figure 6-1

6.2 Setting the Calibration Parameters

The camera ships with default calibration parameters for each sensor. Each sensor allows up to four (4) distinct calibration settings. To adjust these parameters, follow these steps.

1. Access the Web interface for the camera.
2. Click the Event menu from the left side of the main page.
3. Choose the Smart Track link.

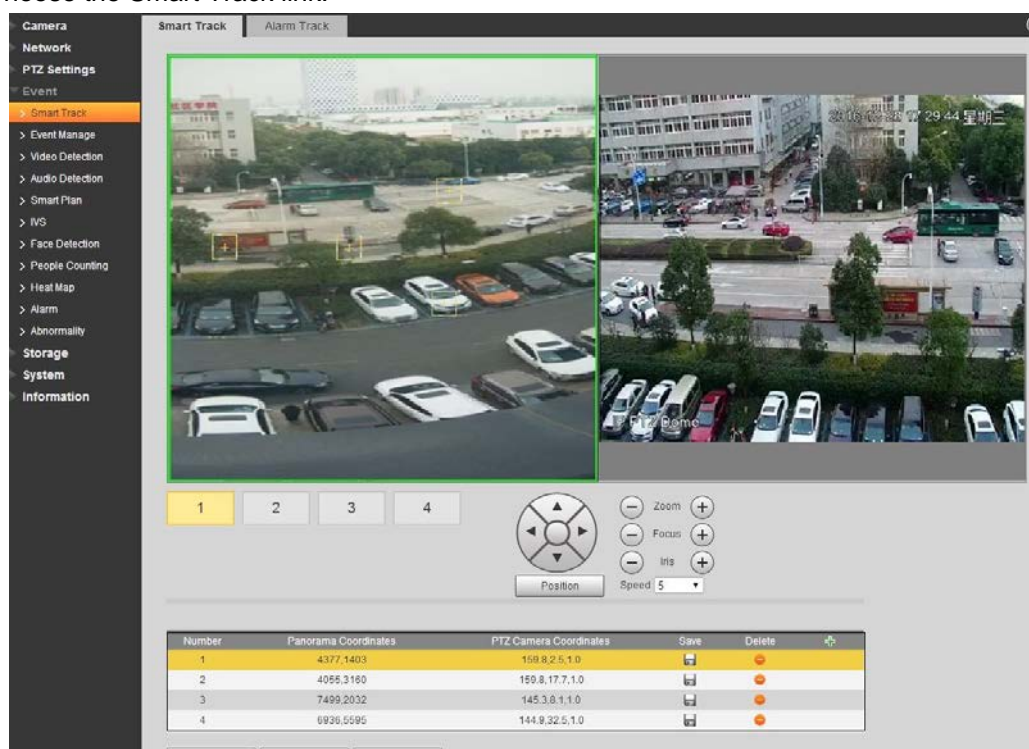

Figure 6-2

- Select the sensor number, located under the live video image, to set the calibration point for a specific sensor.

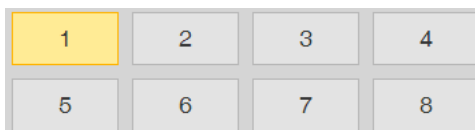
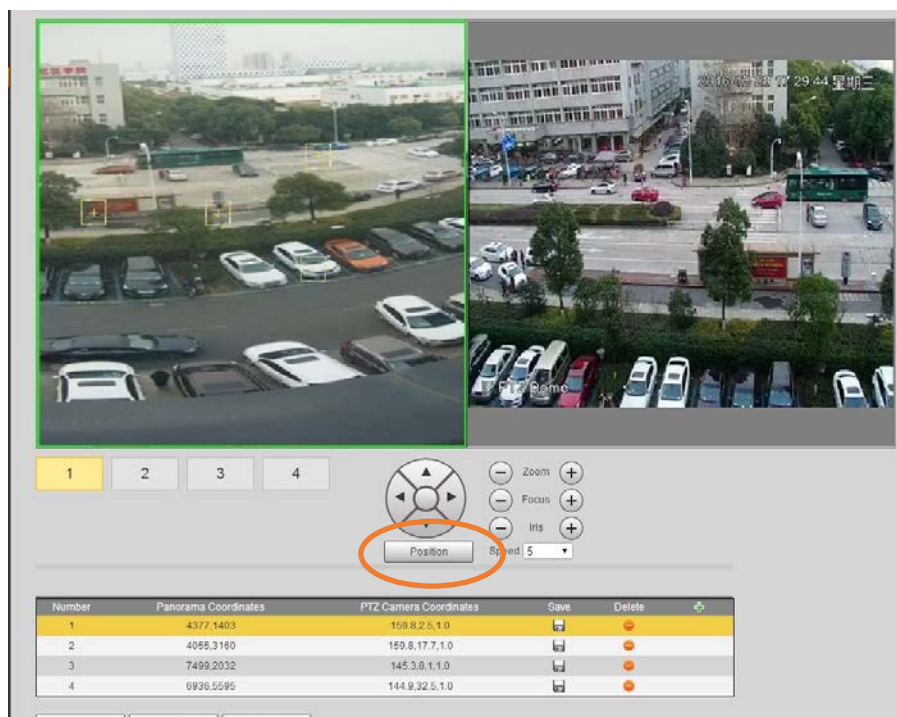

Figure 6-3

- Click the green plus icon in the coordinate box to display the calibration box in the panoramic live view window.

Number	Panorama Coordinates	PTZ Camera Coordinates	Save	Delete	
1	4377,1403	159.8,2.5,1.0			
2	4055,3160	159.8,17.7,1.0			
3	7499,2032	145.3,8.1,1.0			
4	6936,5595	144.9,32.5,1.0			

- Drag the calibration box to the desired location.
- Click the Position button, under the PTZ controls.



- Click the Save icon for the corresponding calibration number.
- Set up to three more calibration parameters for the selected sensor.
- Repeat this procedure for each sensor that you want to set calibration parameters.

Dahua Technology USA Inc.

23 Hubble, Irvine, CA 92618

Tel: (949) 679-7777

Fax: (949) 679-5760

Email: sales.usa@global.dahuatech.com

Rev 001.001 © 2017 Dahua. All rights reserved. Design and specifications are subject to change without notice.