

2 MP Box Network Camera

2 MP WDR Box Network Camera



- 1/2.8-in. 2 MP Progressive-scan CMOS Sensor
- Triple-stream Encoding with Smart H.265+ Compression
- 1080p (1920 x 1080) at 60 fps
- Smart Detection Supported
- True Wide Dynamic Range (120 dB) and Day/Night IR Cut Filter
- Intelligent Video System with Facial Detection
- Alarm and Audio Inputs/Outputs
- Auto Back Focus (ABF)
- Micro SD Memory, PoE
- 5-year Warranty



System Overview

Dahua's Pro series of cameras offers high-resolution video and cutting-edge technology in a compact and accessible package. The cameras feature H.265 video compression, reducing bandwidth and storage requirements without sacrificing video quality. The camera series incorporates True Wide Dynamic Range, and the Intelligent Video System, features typically found on high-end surveillance systems.

Functions

Starlight Technology

For challenging low-light applications, Dahua's Starlight Ultra-low Light Technology offers best-in-class light sensitivity, capturing color details in low light down to 0.005 lux. The camera uses a set of optical features to balance light throughout the scene, resulting in clear images in dark environments.

Wide Dynamic Range

For applications with both bright and low-light conditions that change quickly, True WDR (120 dB) optimizes both the bright and dark areas of a scene at the same time to provide usable video.

Intelligent Video System (IVS)

IVS is a built-in video analytic algorithm that delivers intelligent functions to monitor a scene for Tripwire violations, intrusion detection, and abandoned or missing objects. A camera with IVS quickly and accurately responds to monitoring events in a specific area. In addition to scene analytics, the camera supports face detection to quickly capture a face and upload the image to a server. The camera also offers tamper detection by recognizing a dramatic scene change and generating a warning message to inspect the camera.

Street Light Compensation

The camera delivers exceptional images even when shooting under sodium-vapor lamps that typically add a yellowish-tint to the scene hampering identification. This camera provides a built-in white-balance mode that compensates for the tint to restore the scene to its original color.

High Efficiency Video Coding (H.265)

The H.265 (ITU-T VCEG) video compression standard offers double the data compression ratio at the same level of video quality, or substantially improved video quality at the same bit rate, as compared to older video compression technologies. H.265 offers such impressive compression by expanding the pattern comparison and difference-coding, improving motion vector prediction and motion region merging, and incorporating an additional filtering step called sample-adaptive offset filtering.

Smart H.265+

Smart H.265+ is the optimized implementation of the H.265 codec that uses a scene-adaptive encoding strategy, dynamic GOP, dynamic ROI, flexible multi-frame reference structure and intelligent noise reduction to deliver high-quality video without straining the network. Smart H.265+ technology reduces bit rate and storage requirements by up to 70% when compared to standard H.264 video compression.

Environmental

With a temperature range of -30 °C to +60 °C (-22 °F to +140 °F), the camera is designed for extreme temperature environments.

Protection

Supporting ±30% input voltage tolerance, this camera suits even the most unstable conditions for outdoor applications. Its 6KV lightning rating provides protection against the camera and its structure from the effects of lightning.

Technical Specification

Camera

Image Sensor	1/2.8-in. 2 MP Progressive-scan CMOS
Effective Pixels	1920(H) x 1080(V)
RAM/ROM	256 MB /32 MB
Scanning System	Progressive
Minimum Illumination	Color: 0.005 Lux at F1.2 B/W: 0.001 Lux at F1.2
S/N Ratio	More than 50 dB
Lens Mount Type	C/CS

Video

Compression	Smart H.265+, H.265, Smart H.264+, H.264, MJPEG
Streaming Capability	Three (3) Streams
Resolution	1080p (1920 x 1080), 1.3 MP (1280 x 960), 720p (1280 x 720), D1 (704 x 480), VGA (640 x 480), CIF (352 x 240)
Frame Rate	Main Stream: 1080p at 60 fps
	Sub Stream 1: D1 at 60 fps
	Sub Stream 2: 1080p at 30 fps
Bit Rate Control	CBR/VBR
Bit Rate	H.264: 24 Kbps to 9472 Kbps H.265: 14 Kbps to 5632 Kbps
Day/Night	Auto (ICR), Color, B/W
BLC Mode	BLC, HLC, WDR (120 dB)

White Balance	Auto, Natural, Street Lamp, Outdoor, Manual
Gain Control	Auto, Manual
Noise Reduction	3D DNR
Motion Detection	Off, On (4 Zone, Rectangle)
Region of Interest	Off, On (4 Zone)
Digital Zoom	16x
Flip	0° / 90° / 180° / 270°
Mirror	Off, On
Privacy Masking	Off, On (4 Area, Rectangle)

Audio

Compression	G.711a, G.711Mu, AAC, G.726
-------------	-----------------------------

Network

Ethernet	RJ-45 (10/100 Base-T)
Protocol	HTTP, HTTPS, TCP, ARP, RTSP, RTP, UDP, SMTP, FTP, DHCP, DNS, DDNS, PPPoE, IPv4/v6, QoS, UPnP, NTP, Bonjour, 802.1x, Multicast, ICMP, IGMP, SNMP
Interoperability	ONVIF, PSIA, CGI
Streaming Method	Unicast / Multicast
Max. User Access	10 Users /20 Users
Edge Storage	NAS Local PC for Instant Recording MicroSD Card, maximum 128 GB
Web Viewer	IE, Firefox, Safari
Management Software	Smart PSS, DSS
Mobile Operating System	iOS, Android

Certifications

Safety	EN 60950:2000 UL60950-1
Electromagnetic Compatibility	FCC Part 15 Subpart B

Interface

Video Interface	One (1) Port
Audio Interface	Input: One (1) Channel, with One (1) Built-in Microphone Output: One (1) Channel
RS485	One (1) Port
Alarm	Input: Two (2) Channels Output: One (1) Channel

Electrical

Power Supply	12 VDC, 24 VAC, PoE (802.3af Class 0)
Power Consumption	< 5 W

Environmental

Operating Conditions	-30° C to +60° C (-22° F to +140° F), Less than 95% RH
Storage Conditions	-30° C to +60° C (-22° F to +140° F), Less than 95% RH

Construction

Casing	Metal
Dimensions	135.40 mm x 74.40 mm x 65.50 mm (5.33 in. x 2.93 in. x 2.58 in.)
Net Weight	0.66 kg (1.46 lb)
Gross Weight	0.77 kg (1.70 lb)

Intelligence

IVS triggers an alarm and takes a defined action for the following events:

Standard Features	<ul style="list-style-type: none"> • Tampering with the camera. • Error writing to an onboard Micro SD card. • Error sending or receiving data over the network. • Unauthorized access to the camera.
Premium Features	
Motion	An object moves through any part of the scene.
Tripwire	A target crosses a user-defined line.
Intrusion	A target enters or exits a defined perimeter.
Scene Change	A person or object moves the camera to change the scene or covers the camera to obscure the scene.
Abandoned/Missing Object	A target leaves an object in designated area, or a target removes an object from the same designated area.
Advanced Features	
Facial Detection	Detects and captures a snapshot of human face in a defined area within a scene.

Ordering Information

Type	Part Number	Description
Camera	N25BA5	2 MP Box Network Camera, WDR, IVS
Accessories (optional)	PFB110W	Wall Mount
	PFB121W	Wall Mount
	PFA121	Junction Box (use with PFB121W)
	PFA122	Junction Box (use with PFB110W)
	PFA150	Pole Mount
	PFA151	Corner Mount
	PFA152	Pole Mount

Accessories

Optional:

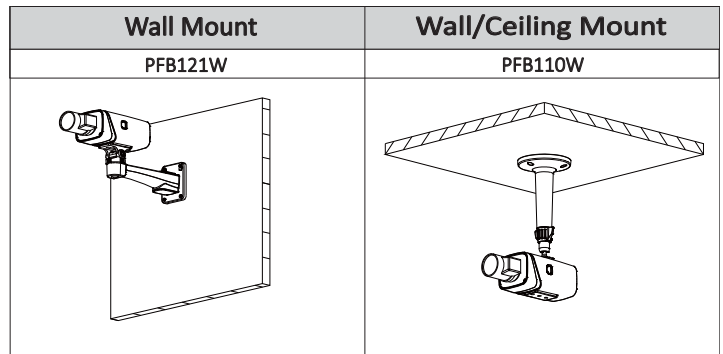

Dimensions (mm/inch)

